

ProVu PD6200 Analog Input Rate/Totalizer Instruction Manual



PROVU[®]
SERIES



Rate/Totalizer

- 0-20 mA, 4-20 mA, 0-5 V, 1-5 V, and ± 10 V Inputs
- Displays Rate and Total Simultaneously
- Count Up or Down, Total & Grand Total
- Open Channel Flow with Programmable Exponent
- Non-Resettable Grand Total
- 32-point Linearization
- Dual-Line Display
- NEMA 4X and IP65 Rated Front Panel
- UL Listed & CE Marked
- Display Features 0.6" & 0.46" Digits
- Six Full Digits on Each Line
- Optional Superluminous Sunlight Readable Display
- Free USB Programming Software & Cable
- 2 or 4 Relays + Isolated 4-20 mA Output Options
- USB, RS-232, & RS-485 Serial Communication Options
- External 4-Relay & Digital I/O Expansion Modules
- Input Power Options Include 85-265 VAC or 12-24 VDC
- Isolated 24 VDC @ 200 mA Transmitter Power Supply
- Modbus[®] RTU Communication Protocol Standard

PRECISION DIGITAL CORPORATION



233 South Street • Hopkinton MA 01748 USA
Tel (800) 343-1001 • Fax (508) 655-8990

**PRECISION
DIGITAL** 

www.predig.com

Disclaimer

The information contained in this document is subject to change without notice. Precision Digital makes no representations or warranties with respect to the contents hereof; and specifically disclaims any implied warranties of merchantability or fitness for a particular purpose.

	
CAUTION: <i>Read complete instructions prior to installation and operation of the meter.</i>	WARNING: <i>Risk of electric shock or personal injury.</i>

Warning
<i>This product is not recommended for life support applications or applications where malfunctioning could result in personal injury or property loss. Anyone using this product for such applications does so at his/her own risk. Precision Digital Corporation shall not be held liable for damages resulting from such improper use.</i>

Limited Warranty

Precision Digital Corporation warrants this product against defects in material or workmanship for the specified period under “Specifications” from the date of shipment from the factory. Precision Digital’s liability under this limited warranty shall not exceed the purchase value, repair, or replacement of the defective unit.

Registered Trademarks

PROVU® and MeterView® Pro are registered trademarks of Precision Digital Corporation. Modbus® is a Registered Trademark of Schneider Automation Inc. All other trademarks mentioned in this document are the property of their respective owners.

© 2017 Precision Digital Corporation. All rights reserved.

www.predig.com

Table of Contents

Table of Contents	3	Programming Time Delay	30
Table of Figures	4	Relay Action for Loss of 4-20 mA Input (Loop Break)	30
Introduction	4	30
Ordering Information	5	Relay and Alarm Operation Diagrams	31
Specifications	6	High Alarm Operation (Set > Reset)	31
General	6	Low Alarm Operation (Set < Reset)	31
Process Input	6	High Alarm with Fail-Safe Operation (Set > Reset)	31
Rate/Totalizer	7	31
Relays	7	Low Alarm with Fail-Safe Operation (Set < Reset)	31
Isolated 4-20 mA Transmitter Output	8	Pump Alternation Control Operation	32
Modbus® RTU Serial Communications	8	Rate Relay Sampling Operation	32
PDA1044 Digital Input & Output Expansion Module	8	Total Relay Sampling Operation	32
.....	8	Signal Loss or Loop Break Relay Operation	33
MeterView Pro	8	Time Delay Operation	33
Compliance Information	9	Relay Operation Details	34
Safety	9	Overview	34
Electromagnetic Compatibility	9	Relays Auto Initialization	34
Safety Information	10	Fail-Safe Operation	34
Installation	10	Front Panel LEDs	34
Unpacking	10	Latching and Non-Latching Relay Operation	35
Panel Mounting Instructions	10	Non-Latching Relay (R _{ULTA})	35
Mounting Dimensions	11	Non-Latching Relay (R _{NONRN})	35
Transmitter Supply Voltage Selection (P+, P-)	11	Latching Relay (LR _{LCH})	35
Connections	12	Latching Relay (LR _{LCL})	35
Connectors Labeling	12	Acknowledging Relays	36
Power Connections	12	Pump Alternation Control Applications (RL _{LEEN})	36
Signal Connections	13	Setting Up the Interlock Relay (Force On) Feature	38
Modbus RTU Serial Communications	14	Scaling the 4-20 mA Analog Output (R_{OUT})	39
Relay Connections	14	Reset Menu (rESEt)	39
Switching Inductive Loads	14	Control Menu (C_{ontrL})	39
F4 Digital Input Connections	15	Setting Up the Password (PR55)	40
4-20 mA Output Connections	15	Protecting or Locking the Meter	40
Analog Output Transmitter Power Supply	15	Total Reset Password & Non-Resettable Total	40
External Relay & Digital I/O Connections	16	Making Changes to a Password Protected Meter	41
Interlock Relay Feature	16	Disabling Password Protection	41
Setup and Programming	17	Advanced Features Menu	42
Front Panel Buttons and Status LED Indicators	17	Advanced Features Menu & Display Messages	42
MeterView® Pro Software	18	Noise Filter (F _{ILTFR})	43
MeterView Pro Installation	18	Noise Filter Bypass (b _{YP} PR55)	43
Display Functions and Messages	19	Rounding Feature (r _{ound})	44
Main Menu	21	Modbus RTU Serial Communications (SE _r ,RL)	44
Setting Numeric Values	21	Select Menu (SE _{LEct})	45
Setting Up the Rate/Totalizer Meter (SE_{tuP})	22	Signal Input Conditioning (F _{uncti} n)	45
Setting the Input Signal (<i>inPu</i> t)	22	Low-Flow Cutoff (C _{ut} oFF)	46
Setting the Totalizer Features (t _{ot} AL)	22	Totalizer Count Up/Down (C _{oun} t)	46
Setting the Input Units or Custom Tags (u _n it _s)	23	Analog Output Programming (R _{outPr})	47
Setting the Decimal Point (d _{Ec} Pt)	23	Programmable Function Keys User Menu (u _{5Er})	47
Programming the Rate/Totalizer (Pr _{oG})	24	Internal Source Calibration (i _L RL)	49
Setting the Display Parameter & Intensity (d _{5Pl} RY)	27	Meter Operation	50
.....	27	Front Panel Buttons Operation	50
Setting the Relay Operation (r _{EL} RY)	28	Function Keys Operation	50
Relay Assignment (R ₅₅ ,u _n)	29	F4 Operation	50
Setting the Relay Action	29	Maximum/Minimum Readings	50
Programming Set and Reset Points	30	Troubleshooting	51
Setting Fail-Safe Operation	30	Diagnostics Menu (d ,RL)	51
		Determining Software Version	51
		Reset Meter to Factory Defaults	51

Factory Defaults & User Settings-----52 **EU Declaration of Conformity-----55**
 Troubleshooting Tips -----53

Table of Figures

Figure 1: 1/8 DIN Panel Cutout and Mounting	10	Figure 11: AC and DC Loads Protection.....	14
Figure 2: Meter Dimensions - Side View	11	Figure 12: Low Voltage DC Loads Protection	14
Figure 3: Meter Dimensions - Top View	11	Figure 13: F4 Digital Input Connections	15
Figure 4: Transmitter Supply Voltage Selection.....	11	Figure 14: 4-20 mA Output Connections	15
Figure 5: Connector Labeling for Fully Loaded PD6200	12	Figure 15: Expansion Modules & DIN Rail Mounting Kit	16
Figure 6: Power Connections.....	12	Figure 16: External Relays Module Connections	16
Figure 7: Transmitter Powered by Internal Supply ..	13	Figure 17: Digital I/O Module Connections	16
Figure 8: Transmitter Powered by Ext. Supply or Self- Powered	13	Figure 18: Interlock Connection	16
Figure 9: Voltage Input Connections.....	13	Figure 19: Acknowledge Relays w/Function Key or Digital Input	36
Figure 10: Relay Connections.....	14		

Introduction

The PROVU® PD6200 is a multi-purpose, easy-to-use rate/totalizer ideal for flow rate, total, and control applications. Its superluminous LED digits make it easily readable in smoke, dust, fog, and, with the optional SunBright® display, even direct sunlight. It accepts current and voltage signals (e.g. 4-20 mA, 0-10 V). Three of the front panel buttons can be custom-programmed for specific operation.

The basic model includes an isolated 24 VDC transmitter power supply that can be used to power the input transmitter or other devices. An additional isolated 24 VDC power supply is included with the 4-20 mA output option. A digital input, F4, is standard.

A fully loaded PD6200 rate/totalizer meter has the following: four SPDT relays, 4-20 mA output, and two 24 VDC power supplies. The PD6200 capabilities may be enhanced by adding the following external expansion modules: four SPST relays (creating an eight-relay rate/totalizer), two digital I/O modules with four inputs and four outputs each, and USB, RS-232 or RS-485 communication adapters.

The eight relays can be used for alarm indication or process control applications. The 4-20 mA isolated output, Modbus RTU serial communications, and digital I/O options make the PD6200 an excellent addition to any system.

Ordering Information

Standard Models

85-265 VAC Model	12-24 VDC Model	Options Installed
PD6200-6R0	PD6200-7R0	No options
PD6200-6R2	PD6200-7R2	2 relays (PD1102*)
PD6200-6R3	PD6200-7R3	4-20 mA output (PD1103*)
PD6200-6R4	PD6200-7R4	4 relays (PD1104*)
PD6200-6R5	PD6200-7R5	2 relays & 4-20 mA output (PD1105*)
PD6200-6R7	PD6200-7R7	4 relays & 4-20 mA output (PD1107*)
*Model number for replacement option card.		

SunBright Display Models

85-265 VAC Model	12-24 VDC Model	Options Installed
PD6200-6H0	PD6200-7H0	No options
PD6200-6H2	PD6200-7H2	2 relays (PD1102*)
PD6200-6H3	PD6200-7H3	4-20 mA output (PD1103*)
PD6200-6H4	PD6200-7H4	4 relays (PD1104*)
PD6200-6H5	PD6200-7H5	2 relays & 4-20 mA output (PD1105*)
PD6200-6H7	PD6200-7H7	4 relays & 4-20 mA output (PD1107*)
*Model number for replacement option card.		

Accessories

Model	Description
PDA1002	DIN rail mounting kit for two expansion modules
PDA1004	4 SPST (Form A) relays
PDA1044	4 digital inputs & 4 digital outputs (2 may be connected)
PDA1232	RS-232 serial adapter
PDA1485	RS-485 serial adapter
PDA7485-I	RS-232 to RS-422/485 isolated converter
PDA8232-N	USB to RS-232 non-isolated converter
PDA8485-I	USB to RS-422/485 isolated converter
PDA2811	1 Meter Plastic NEMA 4X Enclosure
PDA2812	2 Meter Plastic NEMA 4X Enclosure
PDX6901	Suppressor (snubber): 0.01 μ F/470 Ω , 250 VAC

Specifications

Except where noted all specifications apply to operation at +25°C.

General

Display	Line 1: 0.6" (15 mm) high, red LEDs Line 2: 0.46" (12 mm) high, red LEDs 6 digits: each (-99999 to 999999), with lead zero blanking.
Display Intensity	Eight user selectable intensity levels
Display Update Rate	5/second (200 ms)
Overrange	Display flashes 999999
Underrange	Display flashes -99999
Display Assignment	Display lines 1 & 2 may be assigned to rate, total, grand total, alternate (rate/total, rate/grand total, rate/units, total/units, and grand total/units), set points, max/min, units (line 2 only), and Modbus input. Additional displays are available if parameter ExtRL is OFF , and parameter d-5LR is on : gross, alternating gross/net, PV1, PV2, and PCT (refer to PD6000 instruction manual found on www.predig.com).
Programming Methods	Four front panel buttons, digital inputs, or PC with MeterView Pro software.
Noise Filter	Programmable from 2 to 199 (0 will disable filter)
Filter Bypass	Programmable from 0.1 to 99.9% of calibrated span
Recalibration	All ranges are calibrated at the factory. Recalibration is recommended at least every 12 months.
Max/Min Display	Max/min readings reached by the process are stored until reset by the user or until power to the meter is turned off.
Password	Three programmable passwords restrict modification of programmed settings and two prevent resetting the totals. Pass 1: Allows use of function keys and digital inputs Pass 2: Allows use of function keys, digital inputs and editing set/reset points Pass 3: Restricts all programming, function keys, and digital inputs. Total: Prevents resetting the total manually Gtotal: Prevents resetting the grand total manually
Non-Volatile Memory	All programmed settings are stored in non-volatile memory for a minimum of ten years if power is lost.
Power Options	85-265 VAC 50/60 Hz, 90-265 VDC, 20 W max or 12-24 VDC ± 10%, 15 W max Powered over USB for configuration only
Fuse	Required external fuse: UL Recognized, 5 A max, slow blow; up to 6 meters may share one 5 A fuse

Isolated Transmitter Power Supply	Terminals P+ & P-: 24 VDC ± 10%. 12-24 VDC powered models selectable for 24, 10, or 5 VDC supply (internal jumper J4). 85-265 VAC models rated @ 200 mA max, 12-24 VDC powered models rated @ 100 mA max, @ 50 mA max for 5 or 10 VDC supply.
Normal Mode Rejection	Greater than 60 dB at 50/60 Hz
Isolation	4 kV input/output-to-power line 500 V input-to-output or output-to-P+ supply
Overvoltage Category	Installation Overvoltage Category II: Local level with smaller transient overvoltages than Installation Overvoltage Category III.
Environmental	Operating temperature range: -40 to 65°C Storage temperature range: -40 to 85°C Relative humidity: 0 to 90% non-condensing
Connections	Removable screw terminal blocks accept 12 to 22 AWG wire, RJ45 for external relays, digital I/O, and serial communication adapters.
Enclosure	1/8 DIN, high impact plastic, UL 94V-0, color: black
Mounting	1/8 DIN panel cutout required: 3.622" x 1.772" (92 mm x 45 mm) Two panel mounting bracket assemblies are provided.
Tightening Torque	Screw terminal connectors: 5 lb-in (0.56 Nm)
Overall Dimensions	4.68" x 2.45" x 5.64" (119 mm x 62 mm x 143 mm) (W x H x D)
Weight	9.5 oz (269 g)
Warranty	3 years parts & labor

Process Input

Inputs	Field selectable: 0-20, 4-20 mA, ±10 V (0-5, 1-5, 0-10 V), Modbus PV (Slave)
Accuracy	±0.03% of calibrated span ±1 count, square root & programmable exponent accuracy range: 10-100% of calibrated span
Temperature Drift	0.005% of calibrated span/°C max from 0 to 65°C ambient, 0.01% of calibrated span/°C max from -40 to 0°C ambient
Signal Input Conditioning	Linear, square root, programmable exponent, or round horizontal tank volume calculation
Multi-Point Linearization	2 to 32 points
Programmable Exponent	1.0001 to 2.9999
Round H Tank	Diameter & Length: 999.999 inch or cm calculates volume in gallons or liters respectively.

Low-Flow Cutoff	0-999999 (0 disables cutoff function)
Decimal Point	Up to five decimal places or none: <i>d.ddddd, d.ddddd, d.ddd, d.dd, d.d, or d</i>
Calibration Range	Input Range Minimum Span Input 1 & Input 2 4-20 mA 0.15 mA ±10 V 0.01 V An error message will appear if the input 1 and input 2 signals are too close together.
Input Impedance	Voltage ranges: greater than 500 kΩ Current ranges: 50 - 100 Ω (depending on resettable fuse impedance)
Input Overload	Current input protected by resettable fuse, 30 VDC max. Fuse resets automatically after fault is removed.
F4 Digital Input Contacts	3.3 VDC on contact. Connect normally open contacts across F4 to COM.
F4 Digital Input Logic Levels	Logic High: 3 to 5 VDC Logic Low: 0 to 1.25 VDC
Rate/Totalizer	
Rate Display Indication	-99999 to 999999, lead zero blanking. "R" LED illuminates while displaying rate.
Total Display & Total Overflow	0 to 999,999; automatic lead zero blanking. "T" LED is illuminated while displaying total or grand total. Up to 999,999,999 with total-overflow feature. "OF" is displayed to the left of total overflow and ▲ LED is illuminated.
Total Decimal Point	Up to five decimal places or none: <i>d.ddddd, d.ddddd, d.ddd, d.dd, d.d, or d</i> Total decimal point is independent of rate decimal point.
Totalizer	Calculates total based on rate and field programmable multiplier to display total in engineering units. Time base must be selected according to the time units in which the rate is displayed.
Totalizer Rollover	Totalizer rolls over when display exceeds 999,999,999. Relay status reflects display.
Total Overflow Override	Program total reset for automatic with 0.1 second delay and set point 1 for 999,999
Totalizer Presets	Up to eight, user selectable under setup menu. Any set point can be assigned to total and may be programmed anywhere in the range of the meter for total alarm indication.
Programmable Delay On Release	0.1 and 999.9 seconds; applied to the first relay assigned to total or grand total. If the meter is programmed to reset total to zero automatically when the preset is reached, then a delay will occur before the total is reset.
Total Reset	Via front panel button, external contact closure on digital inputs, automatically via user selectable preset value and time delay, or through serial communications.

Total Reset Password	Total and grand total passwords may be entered to prevent resetting the total or grand total from the front panel.
Non-Resettable Total	The grand total can be programmed as a non-resettable total by entering the password "050873".  Caution! <i>Once the Grand Total has been programmed as "non-resettable" the feature <u>cannot</u> be disabled.</i>

Relays

Rating	2 or 4 SPDT (Form C) internal and/or 4 SPST (Form A) external; rated 3 A @ 30 VDC and 125/250 VAC resistive load; 1/14 HP (≈ 50 W) @ 125/250 VAC for inductive loads
Noise Suppression	Noise suppression is recommended for each relay contact switching inductive loads; see page 14 for details.
Relay Assignment	Relays may be assigned to rate, total, or grand total.
Deadband	0-100% of span, user programmable
High Or Low Alarm	User may program any alarm for high or low trip point. Unused alarm LEDs and relays may be disabled (turn off).
Relay Operation	Automatic (non-latching) and/or manual reset Latching (requires manual acknowledge) with/without clear Pump alternation control (2 to 8 relays) Sampling (based on time) Off (disable unused relays and enable Interlock feature) Manual on/off control mode
Relay Reset	User selectable via front panel buttons, digital inputs, or PC 1. Automatic reset only (non-latching), when the input passes the reset point or total is reset to zero. 2. Automatic + manual reset at any time (non-latching) 3. Manual reset only, at any time (latching) 4. Manual reset only after alarm condition has cleared (latching) <i>Note: Front panel button or digital input may be assigned to acknowledge relays programmed for manual reset.</i>
Time Delay	0 to 999.9 seconds, on & off relay time delays Programmable and independent for each relay.
Fail-Safe Operation	Programmable and independent for each relay. <i>Note: Relay coil is energized in non-alarm condition. In case of power failure, relay will go to alarm state.</i>
Auto Initialization	When power is applied to the meter, relays will reflect the state of the input to the meter.

Isolated 4-20 mA Transmitter Output

Output Source	Rate/process, total, grand total, max, min, set points 1-8, or manual control mode		
Scaling Range	1.000 to 23.000 mA for any display range.		
Calibration	Factory calibrated: 4.000 to 20.000 = 4-20 mA output		
Analog Out Programming	23.000 mA maximum for all parameters: Overrange, underrange, max, min, and break		
Accuracy	± 0.1% FS ± 0.004 mA		
Temperature Drift	0.4 µA/°C max from 0 to 65°C ambient, 0.8 µA/°C max from -40 to 0°C ambient <i>Note: Analog output drift is separate from input drift.</i>		
Isolated Transmitter Power Supply	Terminals I+ & R: 24 VDC ± 10%. May be used to power the 4-20 mA output or other devices. Refer to Figure 4 on page 11 and Figure 14 on page 15. All models rated @ 40 mA max.		
External Loop Power Supply	35 VDC maximum		
Output Loop Resistance	Power supply	Minimum	Maximum
	24 VDC	10 Ω	700 Ω
	35 VDC (external)	100 Ω	1200 Ω

Modbus® RTU Serial Communications

Slave Id	1 – 247 (Meter address)
Baud Rate	300 - 19,200 bps
Transmit Time Delay	Programmable between 0 and 199 ms
Data	8 bit (1 start bit, 1 or 2 stop bits)
Parity	Even, Odd, or None with 1 or 2 stop bits

Byte-To-Byte Timeout	0.01 – 2.54 second
Turn Around Delay	Less than 2 ms (fixed)

Note: Refer to the PROVU® Modbus Register Tables located at www.predig.com for details.

PDA1044 Digital Input & Output Expansion Module

Channels	4 digital inputs & 4 digital outputs per module
System	Up to 2 modules for a total of 8 inputs & 8 outputs
Digital Input Logic High	3 to 5 VDC
Digital Input Logic Low	0 to 1.25 VDC
Digital Output Logic High	3.1 to 3.3 VDC
Digital Output Logic Low	0 to 0.4 VDC
Source Current	10 mA maximum output current
Sink Current	1.5 mA minimum input current
+5 V Terminal	To be used as pull-up for digital inputs only Connect normally open pushbuttons across +5 V & DI 1-4.

MeterView Pro

System Requirements	Microsoft® Windows® XP/Vista/7/8/10
Communications	USB 2.0 (Standard USB A to Micro USB B)
Configuration	Configure meters one at a time

Compliance Information

Safety

UL & c-UL Listed	USA & Canada UL 508 Industrial Control Equipment
UL File Number	E160849
Front Panel	UL Type 4X, NEMA 4X, IP65; panel gasket provided
Low Voltage Directive	EN 61010-1:2010 Safety requirements for measurement, control, and laboratory use

Electromagnetic Compatibility



Emissions	EN 55022:2010 Class A ITE emissions requirements
Radiated Emissions	Class A
AC Mains Conducted Emissions	Class A
Immunity	EN 61326-1:2013 Measurement, control, and laboratory equipment EN 61000-6-2:2005 EMC heavy industrial generic immunity standard
RFI - Amplitude Modulated	80 -1000 MHz 10 V/m 80% AM (1 kHz) 1.4 - 2.0 GHz 3 V/m 80% AM (1 kHz) 2.0 - 2.7 GHz 1 V/m 80% AM (1 kHz)
Electrical Fast Transients	±2kV AC mains, ±1kV other
Electrostatic Discharge	±4kV contact, ±8kV air
RFI - Conducted	10V, 0.15-80 MHz, 1kHz 80% AM
AC Surge	±2kV Common, ±1kV Differential
Surge	1KV (CM)
Power-Frequency Magnetic Field	30 A/m 70%V for 0.5 period
Voltage Dips	40%V for 5 & 50 periods 70%V for 25 periods
Voltage Interruptions	<5%V for 250 periods

Note:

Testing was conducted on PD6200 meters installed through the covers of grounded metal enclosures with cable shields grounded at the point of entry representing installations designed to optimize EMC performance.

Declaration of Conformity available at www.predig.com

Safety Information

 CAUTION: <i>Read complete instructions prior to installation and operation of the meter.</i>	 WARNING: <i>Risk of electric shock or personal injury.</i>
 Warning! <i>Hazardous voltages exist within enclosure. Installation and service should be performed only by trained service personnel.</i>	

Installation

There is no need to remove the meter from its case to complete the installation, wiring, and setup of the meter for most applications. Instructions are provided for changing the transmitter power supply to output 5 or 10 VDC instead of 24 VDC, see page 11.

Unpacking

Remove the meter from box. Inspect the packaging and contents for damage. Report damages, if any, to the carrier.

If any part is missing or the meter malfunctions, please contact your supplier or the factory for assistance.

Panel Mounting Instructions

- Prepare a standard 1/8 DIN panel cutout – 3.622" x 1.772" (92 mm x 45 mm). Refer to Figure 1 for more details.
- Clearance: allow at least 6.0" (152 mm) behind the panel for wiring.
- Panel thickness: 0.04" - 0.25" (1.0 mm - 6.4 mm).
Recommended minimum panel thickness to maintain Type 4X rating: 0.06" (1.5 mm) steel panel, 0.16" (4.1 mm) plastic panel.
- Remove the two mounting brackets provided with the meter (back-off the two screws so that there is 1/4" (6.4 mm) or less through the bracket. Slide the bracket toward the front of the case and remove).
- Insert meter into the panel cutout.
- Install mounting brackets and tighten the screws against the panel. To achieve a proper seal, tighten the mounting bracket screws evenly until meter is snug to the panel along its short side. **DO NOT OVER TIGHTEN**, as the rear of the panel may be damaged.

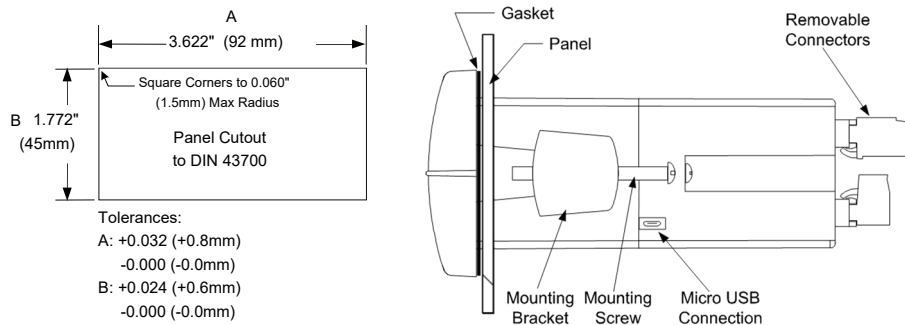

Figure 1: 1/8 DIN Panel Cutout and Mounting

Mounting Dimensions

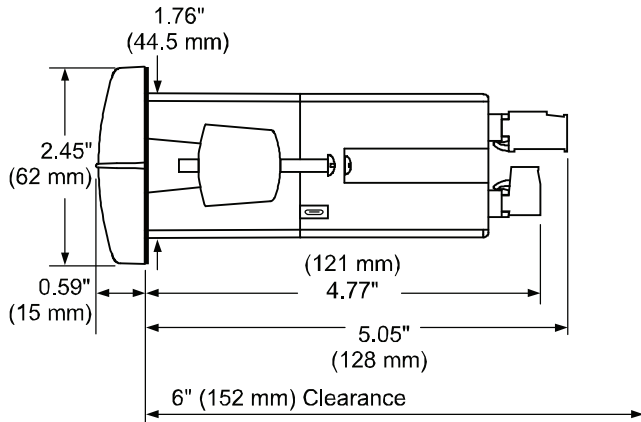

Figure 2: Meter Dimensions - Side View

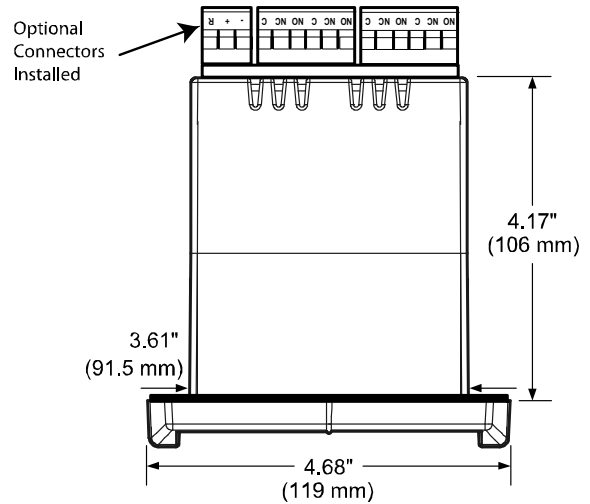

Figure 3: Meter Dimensions - Top View

Transmitter Supply Voltage Selection (P+, P-)

All meters, including models equipped with the 12-24 VDC power option, are shipped from the factory configured to provide 24 VDC power for the transmitter or sensor.

If the transmitter requires 5 or 10 VDC excitation, the internal jumper J4 must be configured accordingly.

To access the voltage selection jumper:

1. Remove all the connectors.
2. Unscrew the back cover.
3. Slide the back cover about 1 inch.
4. Configure the J4 jumper, located behind the input signal connector, for the desired excitation voltage as shown.

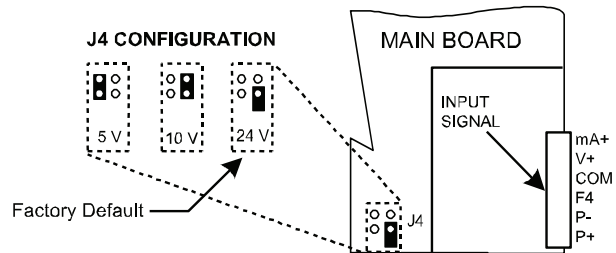



Figure 4: Transmitter Supply Voltage Selection

Connections

All connections are made to removable screw terminal connectors located at the rear of the meter.

 Caution!	<p><i>Use copper wire with 60°C or 60/75°C insulation for all line voltage connections. Observe all safety regulations. Electrical wiring should be performed in accordance with all applicable national, state, and local codes to prevent damage to the meter and ensure personnel safety.</i></p>
--	--

Connectors Labeling

The connectors' label, affixed to the meter, shows the location of all connectors available with requested configuration.

 Warning!	<p><i>Do not connect any equipment other than Precision Digital's expansion modules, cables, or meters to the RJ45 M-LINK connector. Otherwise damage will occur to the equipment and the meter.</i></p>
--	--

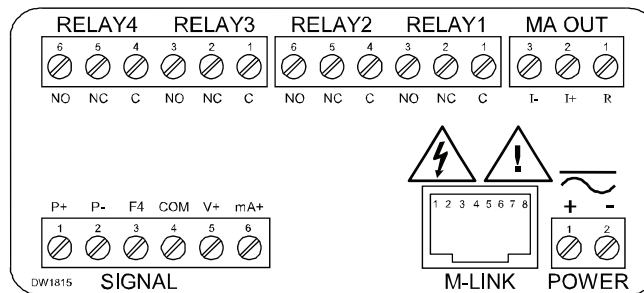

Figure 5: Connector Labeling for Fully Loaded PD6200

Power Connections

Power connections are made to a two-terminal connector labeled POWER on Figure 5. The meter will operate regardless of DC polarity connection. The + and - symbols are only a suggested wiring convention.

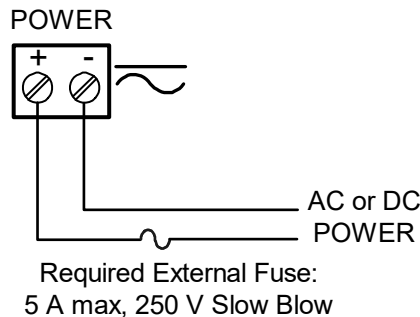

Figure 6: Power Connections

Signal Connections

Signal connections are made to a six-terminal connector labeled SIGNAL on Figure 5. The COM (common) terminal is the return for the 4-20 mA and the ± 10 V input signals.

Current and Voltage Connections

The following figures show examples of current and voltage connections.

There are no switches or jumpers to set up for current and voltage inputs. Setup and programming is performed through the front panel buttons.

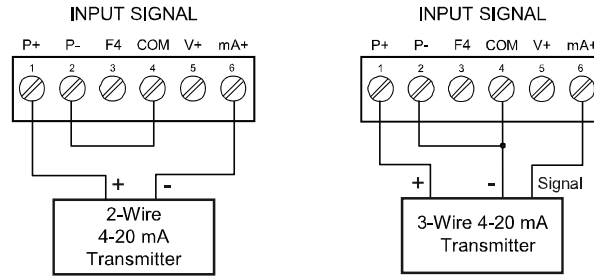

Figure 7: Transmitter Powered by Internal Supply

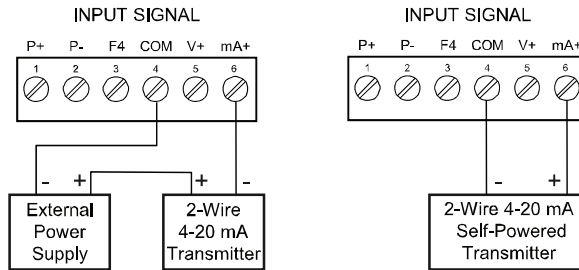

Figure 8: Transmitter Powered by Ext. Supply or Self-Powered

The current input is protected against current overload by a resettable fuse. The display may or may not show a fault condition depending on the nature of the overload.

The fuse limits the current to a safe level when it detects a fault condition, and automatically resets itself when the fault condition is removed.

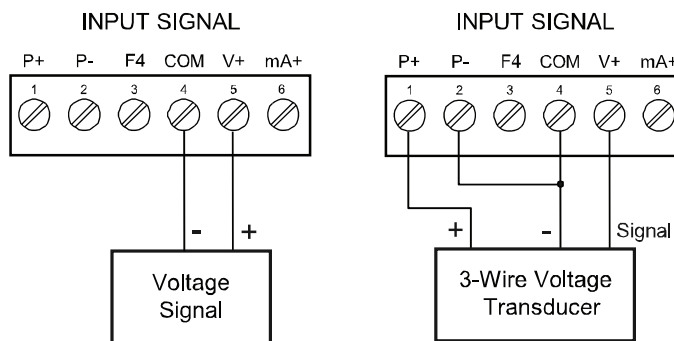

Figure 9: Voltage Input Connections

The meter is capable of accepting any voltage from -10 VDC to +10 VDC.

Modbus RTU Serial Communications

Serial communications connection is made to an RJ45 connector labeled M-LINK on Figure 5. For interfacing to the PROVU®, use the PDA1232 for RS-232 or the PDA1485 for RS-485. The same port is used for interfacing with all expansion modules (e.g. external relays, digital I/O).

Relay Connections

Relay connections are made to two six-terminal connectors labeled RELAY1 – RELAY4 on Figure 5. Each relay's C terminal is common only to the normally open (NO) and normally closed (NC) contacts of the corresponding relay. The relays' C terminals should not be confused with the COM (common) terminal of the INPUT SIGNAL connector.

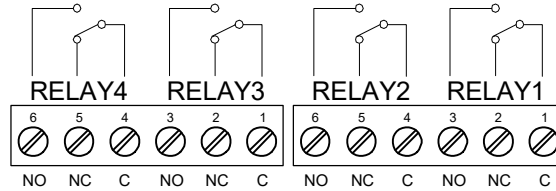

Figure 10: Relay Connections

Switching Inductive Loads

The use of suppressors (snubbers) is strongly recommended when switching inductive loads to prevent disrupting the microprocessor's operation. The suppressors also prolong the life of the relay contacts. Suppression can be obtained with resistor-capacitor (RC) networks assembled by the user or purchased as complete assemblies. Refer to the following circuits for RC network assembly and installation:

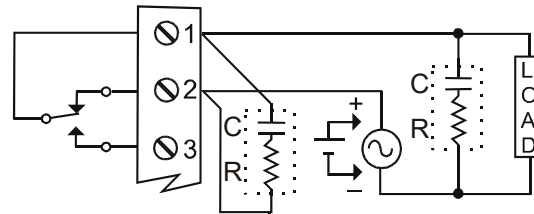

Figure 11: AC and DC Loads Protection

Choose R and C as follows:

- R: 0.5 to 1 Ω for each volt across the contacts
- C: 0.5 to 1 μF for each amp through closed contacts

Notes:

1. Use capacitors rated for 250 VAC.
2. RC networks may affect load release time of solenoid loads. Check to confirm proper operation.
3. Install the RC network at the meter's relay screw terminals. An RC network may also be installed across the load. Experiment for best results.

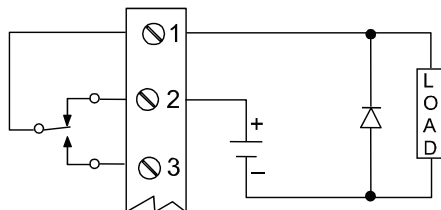

Use a diode with a reverse breakdown voltage two to three times the circuit voltage and forward current at least as large as the load current.

Figure 12: Low Voltage DC Loads Protection

RC Networks Available from Precision Digital

RC networks are available from Precision Digital and should be applied to each relay contact switching an inductive load. Part number: PDX6901.

Note: Relays are de-rated to 1/14th HP (50 watts) with an inductive load.

F4 Digital Input Connections

A digital input, F4, is standard on the meter. This digital input is connected with a normally open contact across F4 and COM, or with an active low signal applied to F4.

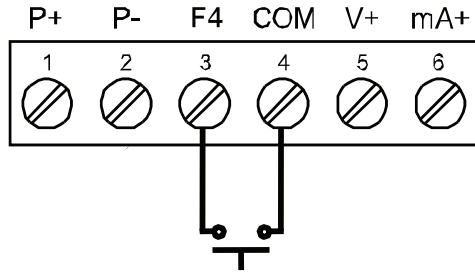

Figure 13: F4 Digital Input Connections

4-20 mA Output Connections

Connections for the 4-20 mA transmitter output are made to the connector terminals labeled MA OUT. The 4-20 mA output may be powered internally or from an external power supply.

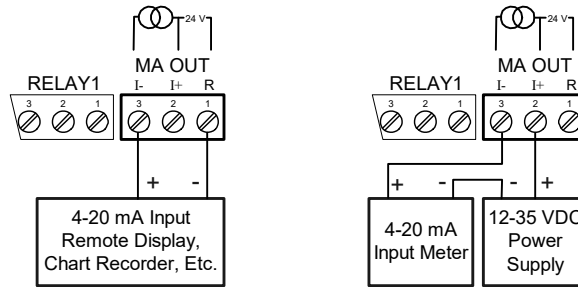

Figure 14: 4-20 mA Output Connections

Analog Output Transmitter Power Supply

The internal 24 VDC power supply powering the analog output may be used to power other devices, if the analog output is not used. The I+ terminal is the +24 V and the R terminal is the return.

External Relay & Digital I/O Connections

The relay and the digital I/O expansion modules PDA1004 & PDA1044 are connected to the meter using a CAT5 cable provided with each module. The two RJ45 connectors on the expansion modules are identical and interchangeable; they are used to connect additional modules to the system.

Note: The jumper located between the RJ45 connectors of the PDA1044 must be removed on the second digital I/O module in order for the system to recognize it as module #2.



Warning! *Do not connect or disconnect the expansion modules with the power on! More detailed instructions are provided with each optional expansion module.*

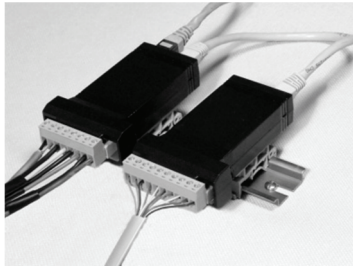

Figure 15: Expansion Modules & DIN Rail Mounting Kit

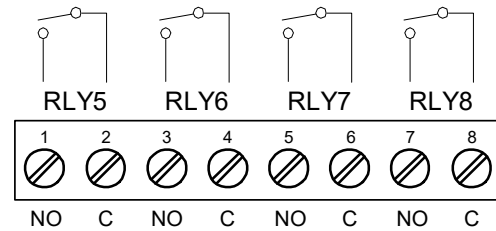

Figure 16: External Relays Module Connections

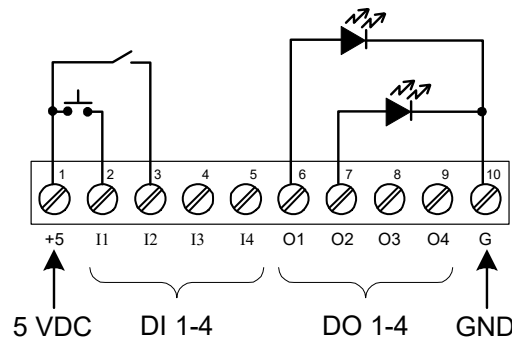

Figure 17: Digital I/O Module Connections

Interlock Relay Feature

As the name implies, the interlock relay feature reassigns one, or more, alarm/control relays for use as interlock relay(s). Interlock contact(s) are wired to digital input(s) and trigger the interlock relay. This feature is enabled by configuring the relay, and relative digital input(s) (see page 38). In one example, dry interlock contacts are connected in series to one digital input which will be used to force on (energize) the assigned interlock power relay when all interlock contacts are closed (safe). The interlock relay front panel LED flashes when locked out. The interlock relay would be wired in-series with the load (N/O contact). See below.

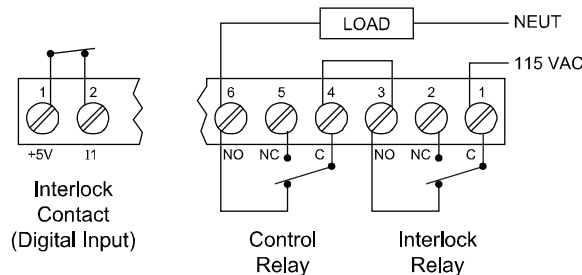

Figure 18. Interlock Connection

Setup and Programming

The meter is factory calibrated prior to shipment to read in milliamps and volts depending on the input selection. The calibration equipment is certified to NIST standards.

Overview

There are no jumpers to set for the meter input selection.

Setup and programming is done through the front panel buttons.

After power and input signal connections have been completed and verified, apply power to the meter.

Front Panel Buttons and Status LED Indicators

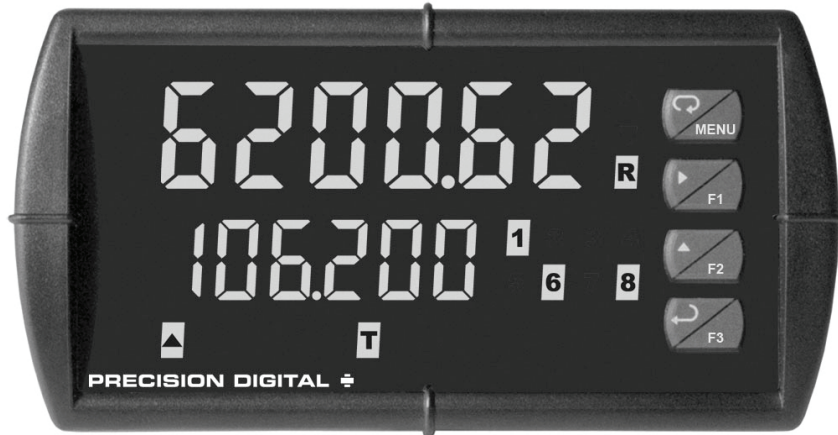

Button	Description	LED	Status
	Menu	1-8	Alarm 1 – 8 indicators. Flashing with M Indicates Manual Control Mode
	Right arrow/F1	R	Rate indicator
	Up arrow/F2	T	Total indicator or Flashing: Tare
	Enter/F3	G T	Grand Total indicator
<i>Note:</i> F4 is a digital input. Alarms 5-8 are enabled when relay expansion module is installed.		▲	Total overflow indicator
		M	Flashing: Manual control of flashing relays. M flashing alone indicates manual analog output. <i>Indicators flash every 10 seconds.</i>

- Press the Menu button to enter or exit the Programming Mode at any time.
- Press the Right arrow button to move to the next digit during digit or decimal point programming.
- Press or hold the Up arrow button to scroll through the menus, decimal point, or to increment the value of a digit.
- Press the Enter button to access a menu or to accept a setting.
- Press and hold the Menu button for three seconds to access the advanced features of the meter.

MeterView® Pro Software

The meter can also be programmed using the PC-based MeterView Pro software included with the meter. This software can be installed on any Microsoft® Windows® (XP/Vista/7/8/10) computer by connecting the meter's onboard USB. The meter is powered by the USB connection, so there is no need to wire anything prior to programming the meter, though USB is intended only for meter configuration.

MeterView Pro Installation

1. Connect one end of the provided USB cable to the meter and the other end to the computer. The computer will automatically install the driver software it needs to talk to the meter.

Only one meter may be connected at a time. Attaching multiple meters will cause a conflict with the meter software.

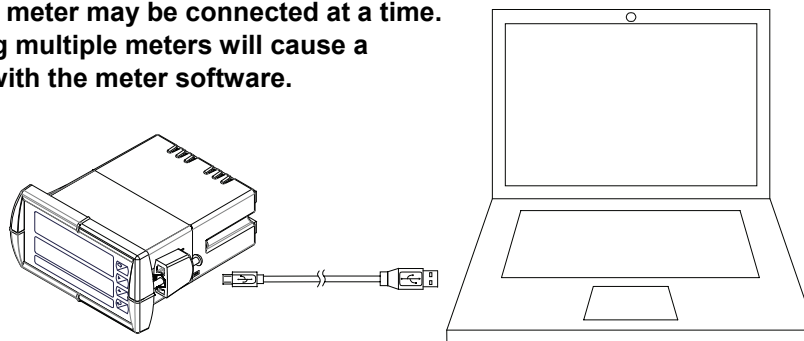

2. Once the driver is installed, an AutoPlay dialog should appear for the drive "MAINSTAL." Click "Open folder to view files." If the computer does not display an AutoPlay dialog for the drive "MAINSTAL," you should open My Computer and double-click on the drive labeled "MAINSTAL."

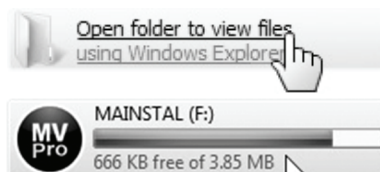

3. Double-click on the file named "MAStart." The program will open a few windows and install two programs on your computer. Simply follow the onscreen instructions until you see one of the dialogs below. If you receive a "User Account Control" warning, click "Yes."

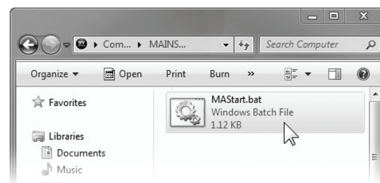

4. If there is an update available, click the "Update" button to install the new version. Otherwise, click "Configure" to begin programming your meter.

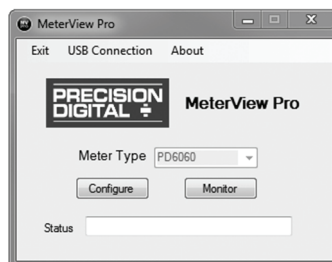
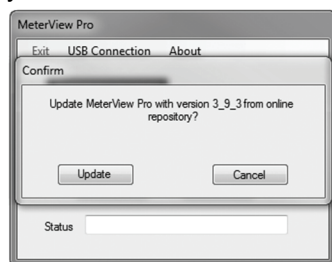

Note: If you decide to update your MeterView Pro software, once the installation has completed, you will be asked if you want to update the setup files located on the meter itself. This way, you will always have the most current version on the meter for future installs.



Do not unplug the meter while the new installation files are being written to it. The meter will display $\mu r t E$ during the process and you will receive an onscreen notification once the process is complete.

Data logging for one meter at a time is available with MeterView Pro software. More advanced data acquisition may be accomplished by using any Modbus RTU compliant software. Additional information regarding configuration and monitoring of the meter using MeterView Pro software is available online. Go to www.predig.com/meterview-pro.

Display Functions and Messages

The meter displays various functions and messages during setup, programming, and operation. The following table shows the main menu functions and messages in the order they appear in the menu.

Display	Parameter	Action/Setting Description	Display	Parameter	Action/Setting Description
SEtUP	Setup	Enter Setup menu	ᄡᄢ ᄡᄢ	Grand total time base	Program grand total time base
INPUt	Input	Enter Input selection menu	ᄡᄢ ᄡF	Grand total conversion factor	Program grand total conversion factor
ᄡᄢ ᄡ	4-20 mA	Set meter for 4-20 mA input	ᄡᄢ ᄡ5ᄢ	Grand total reset	Program grand total rest mode: auto or manual
ᄡᄢᄡᄢ	0-10 VDC	Set meter for ± 10 VDC input	ᄡᄢᄡᄢ	Automatic	Press Enter to set automatic total reset
ᄡᄢᄡᄢ	Total	Enable or disable totalizer features	ᄡ ᄡᄢᄢ	Time delay	Program time delay for total auto reset
d-SCAL	Dual-scale	Enter d-SCAL menu and select Yes for dual-scale or No for single scale display	ᄡᄢ ᄡᄢ	Manual	Press Enter to reset total manually
ᄡᄢᄡᄢ	Units	Select the display units/tags	dSPLY	Display	Enter the Display menu
ᄡᄢᄡᄢ	Rate	Select the display units for rate	ᄡ ᄡᄢ 1	Line 1	Press Enter to assign the Main display parameter (default: PV or rate)
ᄡᄢᄡᄢ	Total	Select the display units for total	ᄡ ᄡᄢ 2	Line 2	Press Enter to assign the small display parameter (default: total)
ᄡᄢᄡᄢ	Grand Total	Select the display units for grand total	d- ᄡᄢᄢ	Display intensity	Set display intensity level from 1 to 8
dEc Pt	Decimal point	Set decimal point for rate, total, grand total	ᄡᄢᄢᄢ	Relay	Enter the Relay menu
PRoG	Program	Enter the Program menu	ᄡ55 ᄡᄢ	Assignment	Assign relays to rate, total, or grand total
INCAL	Input Calibration	Enter the Input Calibration menu	ᄡ5 ᄡᄢ 1	Assign 1	Relay 1 assignment
SCALE	Scale	Enter the Scale menu	ᄡᄢᄡᄢ	Total	Assign relay to total
CAL	Calibrate	Enter the Calibrate menu	ᄡ ᄡᄢᄡᄢ	Grand total	Assign relay to grand total
INP 1	Input 1	Calibrate input 1 signal or program input 1 value	ᄡᄢ ᄡᄢ5	Modbus	Select to display Modbus input or to assign Modbus input as the analog output source
d ᄡᄢ 1	Display 1	Program display 1 value	ᄡᄢᄡᄢ	Rate	Assign relay to rate
INP 2	Input 2	Calibrate input 2 signal or program input 2 value (up to 32 points)	ᄡᄢᄢ 1	Relay 1	Relay 1 setup
d ᄡᄢ 2	Display 2	Program display 2 value (up to 32 points)	ᄡᄢᄢ 1	Action 1	Set relay 1 action
Error	Error	Error, calibration not successful, check signal or programmed value	ᄡᄢᄡᄢ	Automatic	Set relay for automatic reset
ᄡ ᄡᄢ	Total time base	Program total time base	ᄡ-ᄡᄢᄢ	Auto-manual	Set relay for automatic & manual reset any time
ᄡ ᄡF	Total conversion factor	Program total conversion factor	ᄡᄢᄡᄢ	Latching	Set relay for latching operation (relays assigned to rate)
ᄡ ᄡ5ᄢ	Total reset	Program total rest mode: auto or manual			

Display	Parameter	Action/Setting Description	Display	Parameter	Action/Setting Description
Lt-Clr	Latching-cleared	Set relay for latching operation with manual reset only after alarm condition has cleared (relays assigned to rate)	Out 1	Output 1	Program output 1 value (e.g. 4.000 mA)
ALtErn	Alternate	Set relay for pump alternation control (relays assigned to rate)	dis 2	Display 2	Program display 2 value
SAmPL	Sampling	Set relay for sampling operation	Out 2	Output 2	Program output 2 value (e.g. 20.000 mA)
OFF	Off	Disable relay and front panel status LED (Select Off to enable Interlock feature)	rESEt	Reset	Press Enter to access the Reset menu
SEt 1	Set 1	Program set point 1	rSt Gt	Reset grand total	Press Enter to reset grand total
rSt 1	Reset 1	Program reset point 1	rSt Hi	Reset high	Press Enter to reset max display
rLY 2	Relay 2	Relays 2-8 setup <i>Note: Relays 5-8 are shown, only if expansion relay module is installed.</i>	rSt Lo	Reset low	Press Enter to reset min display
FRILSF	Fail-safe	Enter Fail-safe menu	rSt HL	Reset high & low	Press Enter to reset max & min displays
FLS 1	Fail-safe 1	Set relay 1 fail-safe operation	rSt t	Reset total	Press Enter to reset total
on	On	Enable fail-safe operation	rSt tr	Reset tare	Reset tare (Used when tAtRL is on only)
oFF	Fail-safe off	Disable fail-safe operation	ContRL	Control	Enter Control menu
dELAY	Delay	Enter relay Time Delay menu	RuLo	Automatic	Press Enter to set relays and analog output for automatic operation
dLY 1	Delay 1	Enter relay 1 time delay setup	MAN	Manual	Press Enter to manually control relays or analog output operation
On 1	On	Set relay 1 On time delay	PASS	Password	Enter the Password menu
OFF 1	Off	Set relay 1 Off time delay	PASS 1	Password 1	Set or enter Password 1
brERH	Loop break	Set relay condition if loop break detected (For mA input only)	PASS 2	Password 2	Set or enter Password 2
IgnorE	Ignore	Ignore loop break condition (Processed as a low signal condition)	PASS 3	Password 3	Set or enter Password 3
On	On	Relay goes to alarm condition when loop break is detected	tAtRL	Total password	Set or enter password for manual reset
OFF	Off	Relay goes to non-alarm condition when loop break is detected	GtAtRL	Grand total password	Set or enter password for manual reset
Rout	Analog output	Enter the Analog output scaling menu	nonrSt	Non-resettable	Non-resettable grand total set after entering "050873" for Gtotal password
dis 1	Display 1	Program display 1 value	unLoc	Unlocked	Program password to lock meter
			Locd	Locked	Enter password to unlock meter
			999999 -999999	Flashing display	Overrange condition Underrange condition

Main Menu

The main menu consists of the most commonly used functions: *Reset, Control, Setup, and Password.*

- Press Menu button to enter Programming Mode, then press the Up arrow button to scroll main menu.
- Press Menu, at any time, to exit and return to Run Mode. Changes made to settings prior to pressing Enter are not saved.
- Changes to the settings are saved to memory only after pressing Enter/F3.
- The display moves to the next menu every time a setting is accepted by pressing Enter/F3.

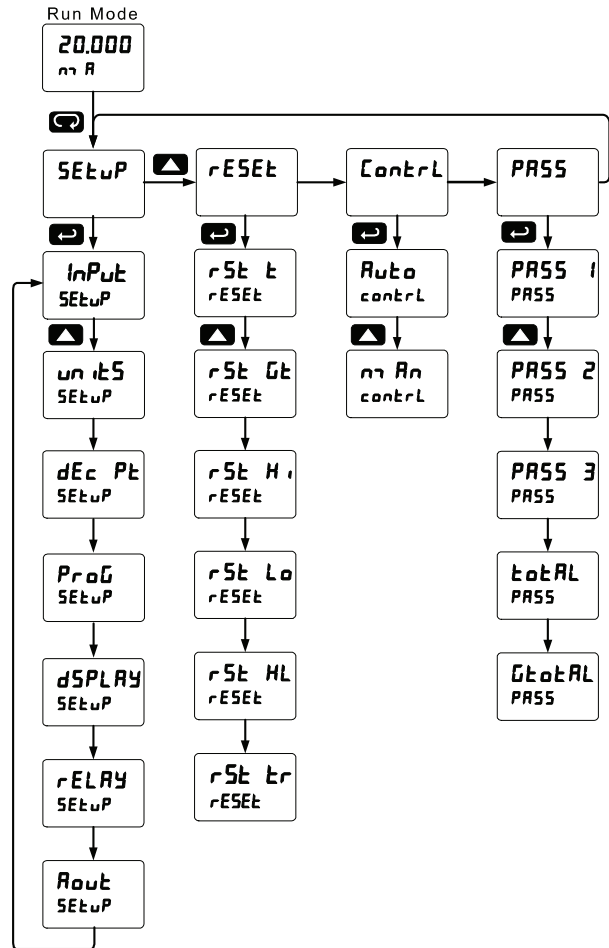

Setting Numeric Values

The numeric values are set using the Right and Up arrow buttons. Press Right arrow to select next digit and Up arrow to increment digit value. The digit being changed is displayed brighter than the rest. Press and hold Up to auto-increment the display value. If negative numbers are allowed, the first digit position will include a negative symbol (-) after the 9.

Press the Enter button, at any time, to accept a setting or Menu button to exit without saving changes.

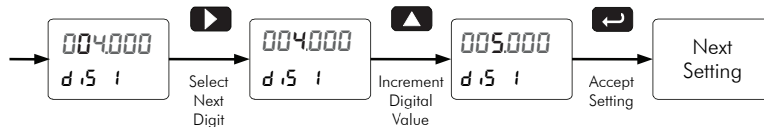

Setting Up the Rate/Totalizer Meter (SEtUP)

The Setup menu is used to select:

1. Input signal the meter will accept and enable totalizer features
2. Select the display units/tags
3. Select the decimal point position
4. Meter programming & input calibration
5. Display parameter and intensity
6. Relay operation
7. 4-20 mA analog output scaling

Press the Enter button to access any menu or press Up arrow button to scroll through choices. Press the Menu button to exit at any time.

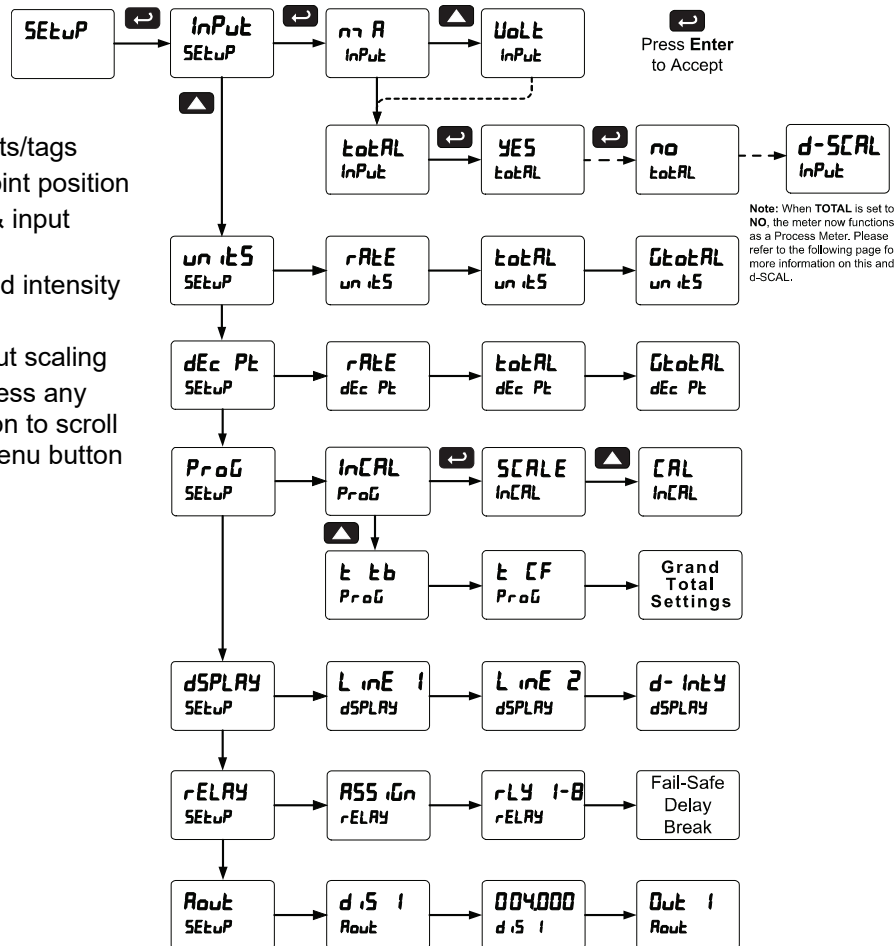

Setting the Input Signal (InPUt)

Enter the *Input* menu to set up the meter to display current (mA) or voltage (VOLT) inputs.

The current input is capable of accepting any signal from 0 to 20 mA. Select current input to accept 0-20 mA or 4-20 mA signals.

The voltage input is capable of accepting any signal from -10 to +10 VDC. Select voltage input to accept 0-5, 1-5, 0-10, or ±10 VDC signals.

Setting the Totalizer Features (tOtAL)

To simply not display the total, select alternative display parameters in the display (dSPLAY) menu.

Enable or disable the totalizer features by selecting “YES” or “no” after the input type has been set up. If the totalizer features are disabled, all the totalizer features and functions are hidden from the menus. Level and process meter features and functions are added to the menus.

If disabling the tOtAL parameter by selecting no, please refer to the PD6000 manual available at www.predig.com for instructions on setting up the meter parameters.

Notes: 1. The totalizer continues working in the background.

2. When selecting “no” for Total, the meter now functions as a PD6000 Process Meter. We strongly suggest that you download and use the PD6000 instruction manual from our website (www.predig.com) while in this mode of operation.

Setting the Input Units or Custom Tags (u n t5)

Enter the input unit or custom tag that will be displayed if alternating rate, total, or grand total and units is selected in the units menu, or d u n t5 is selected as the line 2 parameter. See the flow chart on page 27 to access the display menu to show the unit or tag on line 2. The engineering units or custom legends can be set using the following 7-segment character set:

Display	Character	Display	Character	Display	Character	Display	Character
	0		C		K		V
	1		c		L		w
	2		d		m		X
	3		E		n		Y
	4		F		O		Z
	5		G		o		-
	6		g		P		/
	7		H		q		[
	8		h		r]
	9		l		S		=
	A		i		t		Degree(<)
	b		J		u		Space

Notes:

Degree symbol represented by (<) if programming with MeterView® Pro.

The letters “m” and “w” use two 7-segment LEDs each; when selected the characters to the right are shifted one position.

Press and hold up arrow to auto-scroll the characters in the display.

Setting the Decimal Point (dE c P t)

The decimal point may be set with up to five decimal places or with no decimal point at all. The rate, total, and grand total decimal points are independent.

Pressing the Right arrow moves the decimal point one place to the right until no decimal point is displayed then it moves to the leftmost position. Pressing the Up arrow moves the decimal point one place to the left.

Programming the Rate/Totalizer (Prog)

It is **very important** to read the following information, before proceeding to program the meter:

- The meter is factory calibrated prior to shipment to read in milliamps and volts depending on the input selection. The calibration equipment is certified to NIST standards.
- Use the *Scale* menu to scale process inputs (e.g. 4-20 mA). A calibrated signal source is not needed to scale the meter.
- Use the *Calibrate* menu to apply a signal from a calibrator or a flowmeter.

The *Program* menu contains the following menus:

1. Scale without a signal source
2. Calibrate with a calibrated signal source
3. Total time base & conversion factor
4. Grand total time base & conversion factor
5. Total reset mode for total & grand total

*Note: The Scale and Calibrate functions are exclusive of each other. The meter uses the last function programmed. Only one of these methods can be employed at a time. The Scale and Calibrate functions can use up to 32 points (default is 2). The number of points should be set in the Advanced menu under the **Multi-Point Linearization (LnCAL)** menu selection prior to scaling and calibration of the meter, see page 45 for details.*

The process input may be calibrated or scaled to any display value within the range of the meter.

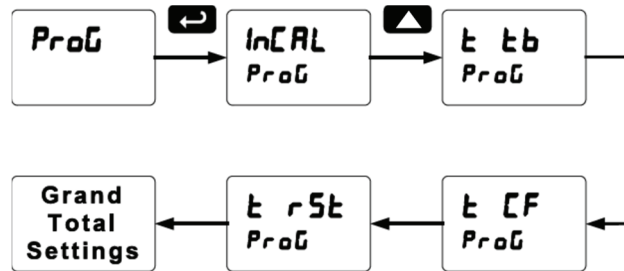

Additional parameters, not needed for most applications, are programmed in the *Advanced Features* menu; see *Advanced Features Menu*, page 42.

Multi-Point Calibration & Scaling

The meter is set up at the factory for 2-point linear calibration. The number of points for multi-point calibration/scaling is set up in the *Advanced Features* menu. Up to 32 linearization points may be selected. See page 45 for details.

on page 5 for details.

Input Calibration Method (LnCAL)

There are two methods of calibrating (or scaling) the display to show the correct engineering units.

- Use the *Scale* menu to enter the scaling without a signal source.
- Use the *Calibrate* menu to apply a signal from a signal source.

Note: The Scale and Calibrate functions are exclusive of each other. The meter uses the last function programmed. Only one of these methods can be employed at a time. The Scale and Calibrate functions can use up to 32 points (default is 2). The number of points should be set in Scale and Calibrate accordingly under the Number of Points (nPt5) menu selection prior to scaling and calibration of the meter, see page 45 for details.

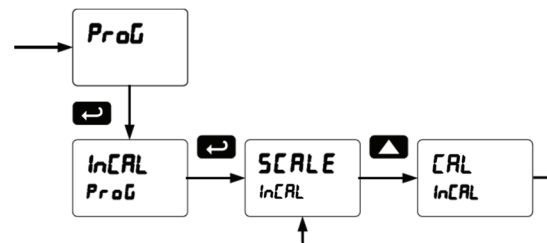

Scaling the Meter (SCALE)

The process inputs (4-20 mA and ±10 VDC) can be scaled to display the process variable in engineering units.

A signal source is not needed to scale the meter; simply program the inputs and corresponding display values.

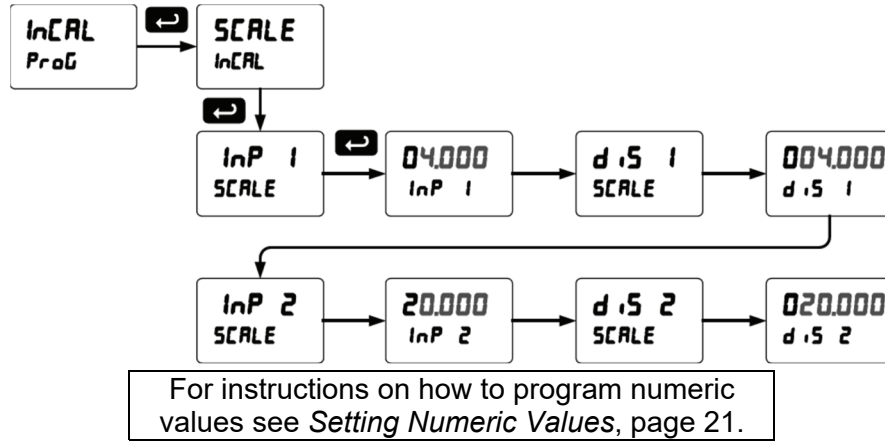

Error Message (Error)

An error message indicates that the calibration or scaling process was not successful.

After the error message is displayed, the meter reverts to the input prior to the failure during calibration or scaling and to input 1 during internal calibration, allowing the appropriate input signal to be applied or programmed.

The error message might be caused by any of the following conditions:

1. Input signal is not connected to the proper terminals or it is connected backwards.
2. Wrong signal selection in *Setup* menu.
3. Minimum input span requirements not maintained.
4. Input 1 signal inadvertently applied to calibrate input 2.

Minimum Input Span

The minimum input span is the minimum difference between input 1 and input 2 signals required to complete the calibration or scaling of the meter.

Input range	Input 1 & input 2 span
4-20 mA	0.15 mA
±10 VDC	0.01 VDC

Calibrating the Meter with External Source (CAL)

The meter can be calibrated to display the process variable in engineering units by applying the appropriate input signal and following the calibration procedure.

The use of a calibrated signal source is strongly recommended to calibrate the meter.

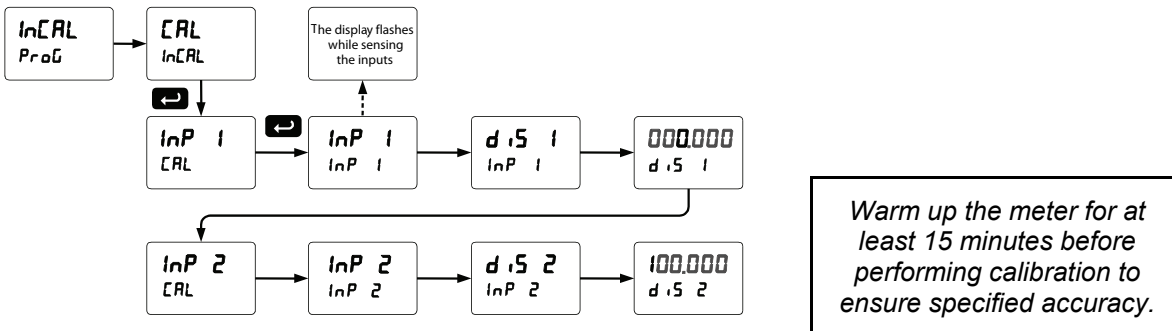

Time Base, Total Conversion Factor & Total Reset

The time base, total conversion factor, and total reset menus are located in the *Program* menu. The total and grand total have their own independent settings. This means that one can be displaying the value in gallons while the other displays in million gallons, liters, m³, etc.

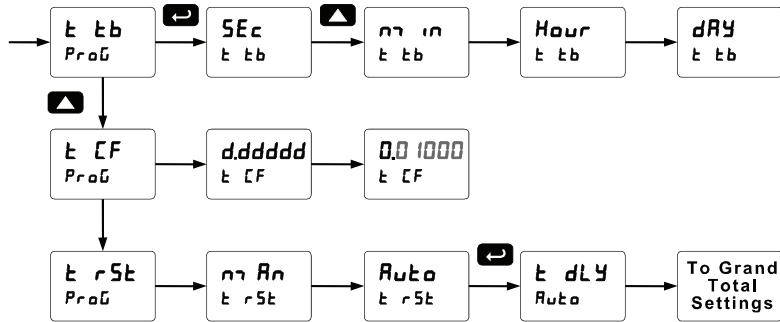

Time Base

The time base is the amount of time over which the rate parameter should accrue. For example, if the rate was ten and the time base was in minutes, then the total would increase by ten every one minute.

Total & Grand Total Conversion Factor

The total & grand total conversion factor is the amount by which the rate is multiplied before it is added to the total or grand total. For Example, if the rate was ten per second and the total conversion factor was 100, the total would increase by 1000 every second. This is useful, for instance, if you want to show rate in gallons and total in thousands of gallons.

Total & Grand Total Reset

The totals can be programmed for manual or automatic reset. In the automatic reset mode, a programmable time delay is available to reset the total or grand total after the assigned preset is reached.

Non-Resetable Totalizer

The total and grand total can be password-protected to prevent unauthorized resets. The grand total can be programmed as a non-resettable total, see page 40 for details.

Setting the Display Parameter & Intensity (dSPLeY)

Display line 1 can be programmed to display:

1. Rate value
2. Total or grand total
3. Toggle rate/total
4. Toggle rate/G-total
5. Relay set points
6. Toggle rate and units
7. Toggle total and units
8. Toggle grand total and units
9. Max, min, or max & min values
10. Modbus input

Display line 2 can be programmed to display:

1. Engineering units or custom legends for line 1
2. Rate value
3. Total or grand total
4. Toggle rate/total
5. Toggle rate/G-total
6. Relay set points
7. Toggle rate and units
8. Toggle total and units
9. Toggle grand total and units
10. Max, min, or max & min values
11. Modbus input
12. Off (no display)

Selecting engineering units or custom legends as display line 2 (d unit) will display the unit or tag selected for the rate, total, or grand total displayed on line 1.

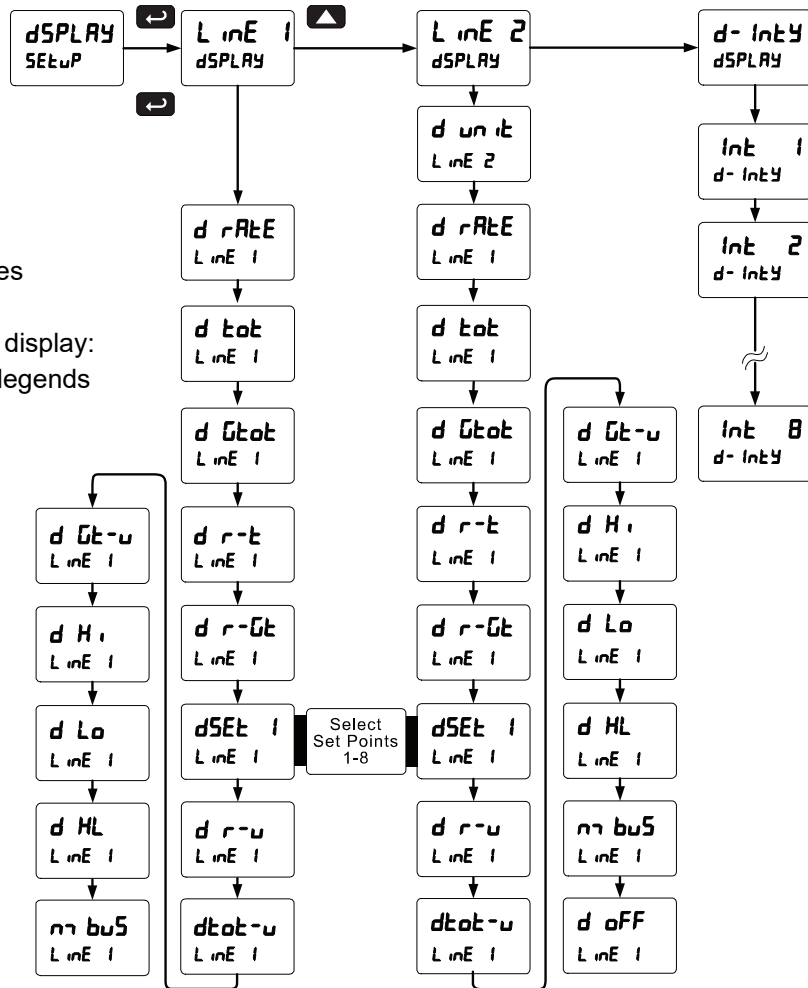

For example, if line 1 is set to *totAL*, selecting *d unit* to display on line 2 will have the total appear on line 1, and the total unit appear on line 2.

Display Intensity: The meter has eight display intensity levels to give the best performance under various lighting conditions. Select intensity 8 for outdoor applications. The default intensity setting is 8.

After setting up the input and the display, press the Menu button to exit programming and skip the rest of the setup menu. Press the Menu button again and the Up arrow to reach the *Program* menu and complete the scaling or calibration of the meter.

Setting the Relay Operation (rELAY)

This menu is used to set up the operation of the relays.



CAUTION! *During setup, the relays do not follow the input and they will remain in the state found prior to entering the Relay menu.*

1. Relay assignment
 - a. Rate for low and high alarm
 - b. Total
 - c. Grand total
 - d. Modbus input process variable
2. Relay action
 - a. Automatic reset only (non-latching)
 - b. Automatic + manual reset at any time (non-latching)
 - c. Latching (manual reset only)
 - d. Latching with Clear (manual reset only after alarm condition has cleared)
 - e. Pump alternation control (automatic reset only)
 - f. Sampling (the relay is activated for a user-specified time)
 - g. Off (relay state controlled by Interlock feature)
3. Set and reset points
4. Fail-safe operation
 - a. On (enabled)
 - b. Off (disabled)
5. Time delay
 - a. On delay (0-999.9 seconds)
 - b. Off delay (0-999.9 seconds)
6. Relay action for loss (break) of 4-20 mA input (ignore, on, off)

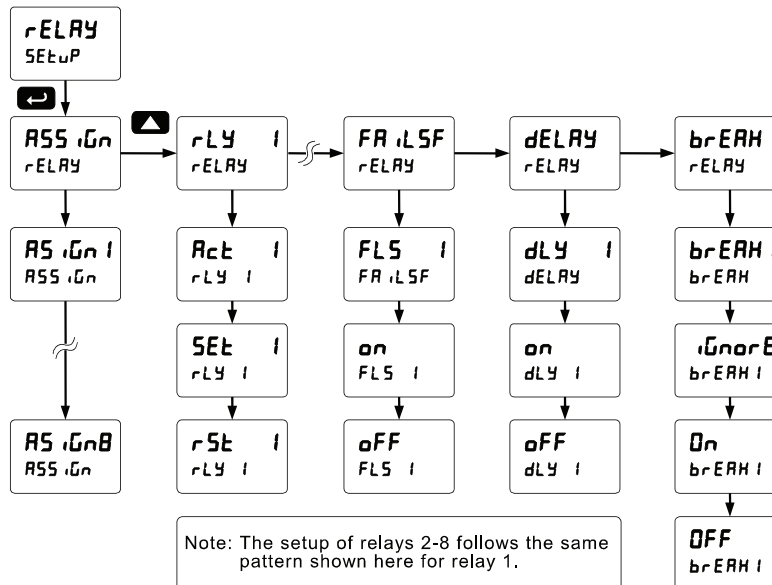

Relay Assignment (R55, Rn)

The relays can be assigned to any of the following parameters:

1. Rate for low or high alarm indication
2. Total for alarm indication
3. Grand total for alarm indication
4. Modbus input process variable

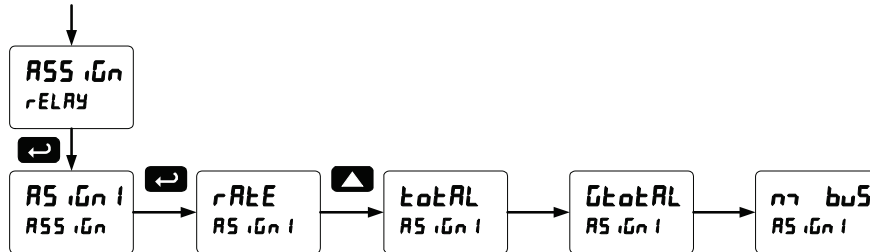

Setting the Relay Action

Operation of the relays is programmed in the *Action* menu. The relays may be set up for any of the following modes of operation:

1. Automatic reset (non-latching)
2. Automatic + manual reset at any time (non-latching)
3. Latching (manual reset only, at any time)
4. Latching with Clear (manual reset only after alarm condition has cleared)
5. Pump alternation control (automatic reset only)
6. Sampling (the relay is activated for a user-specified time)
7. Off (relay state controlled by Interlock feature)

The following graphic shows relay 1 action setup; relay 2-8 are set up in a similar fashion.

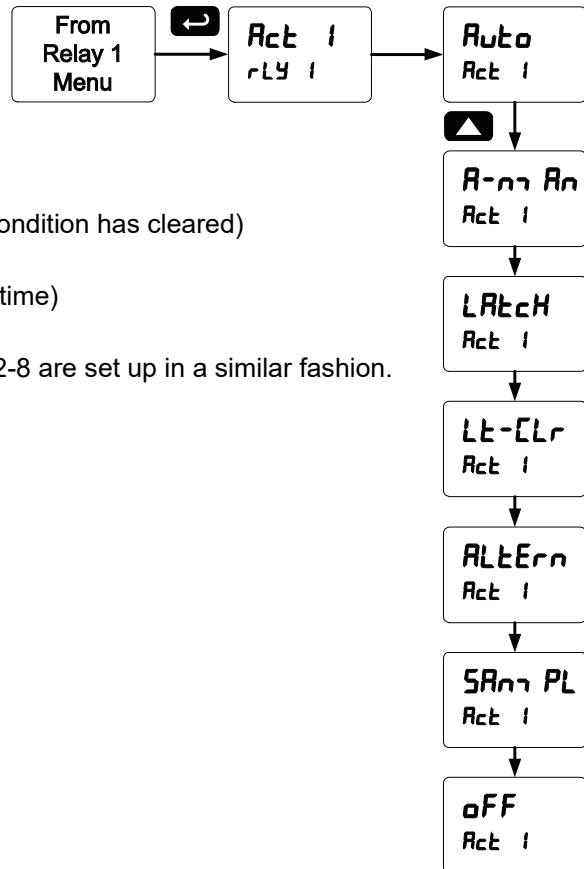

Programming Set and Reset Points

High alarm indication: program set point above reset point.

Low alarm indication: program set point below reset point.

The deadband is determined by the difference between set and reset points. Minimum deadband is one display count. If the set and reset points are programmed with the same value, the relay will reset one count below the set point.

Note: Changes are not saved until the reset point has been accepted.

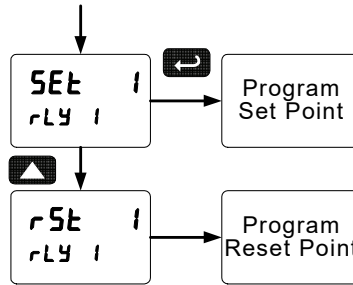

Setting Fail-Safe Operation

In fail-safe mode of operation, the relay coil is energized when the process variable is within safe limits and the relay coil is de-energized when the alarm condition exists. The fail-safe operation is set independently for each relay. Select **on** to enable or select **off** to disable fail-safe operation.

Programming Time Delay

The *On* and *Off* time delays may be programmed for each relay between 0 and 999.9 seconds. The relays will transfer only after the condition has been maintained for the corresponding time delay.

The *On* time delay is associated with the set point.

The *Off* time delay is associated with the reset point.

Relay Action for Loss of 4-20 mA Input (Loop Break)

The loop break feature is associated with the 4-20 mA input. Each relay may be programmed to go to one of the following conditions when the meter detects the loss of the input signal (i.e. < 0.005 mA):

1. Turn *On* (Go to alarm condition)
2. Turn *Off* (Go to non-alarm condition)
3. Ignore (Process as a low signal condition)

Note: This is not a true loop break condition; if the signal drops below 0.005 mA, it is interpreted as a "loop break" condition.

Relay and Alarm Operation Diagrams

The following graphs illustrate the operation of the relays, status LEDs, and ACK button.

High Alarm Operation (Set > Reset)

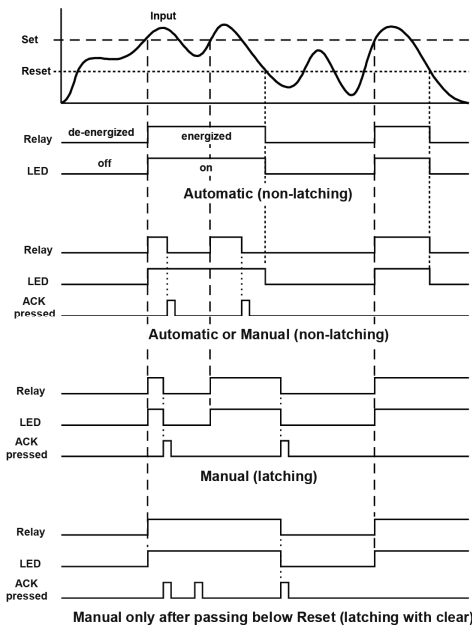

Low Alarm Operation (Set < Reset)

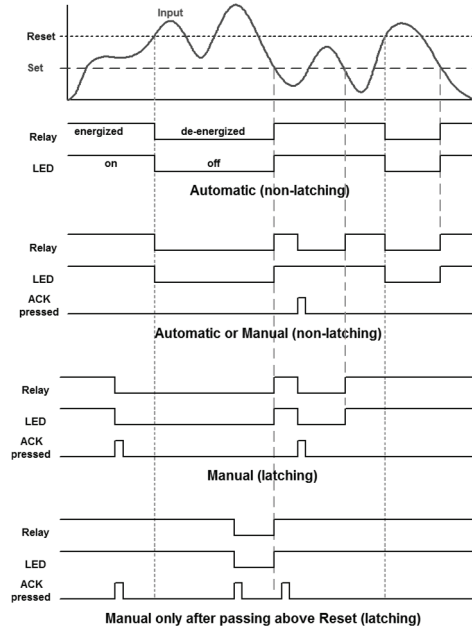

For Manual reset mode, ACK can be pressed anytime to turn "off" relay. To detect a new alarm condition, the signal must go below the set point, and then go above it.

High Alarm with Fail-Safe Operation (Set > Reset)

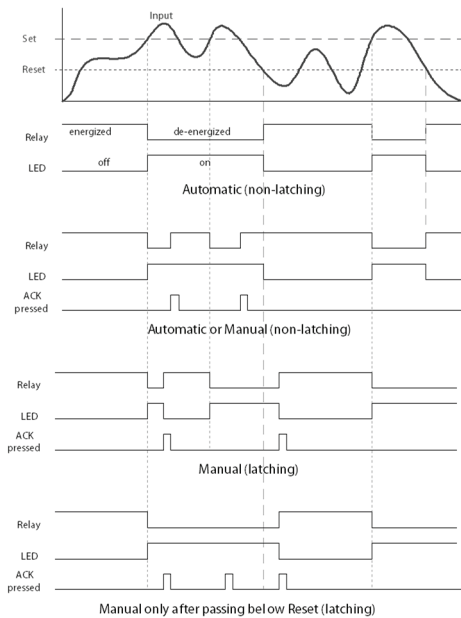

Low Alarm with Fail-Safe Operation (Set < Reset)

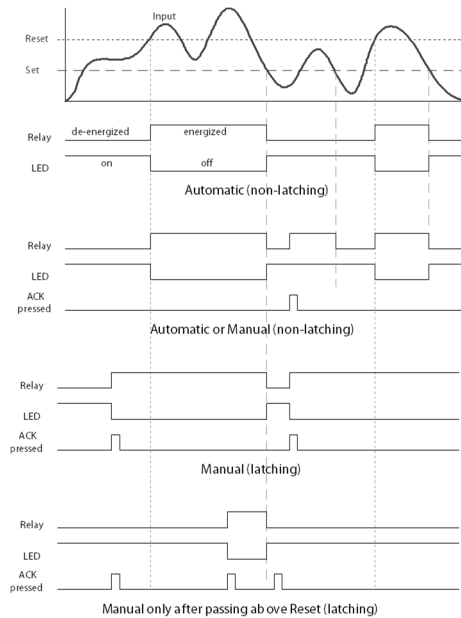

Note: Relay coil is energized in non-alarm condition. In case of power failure, relay will go to alarm state.

Pump Alternation Control Operation

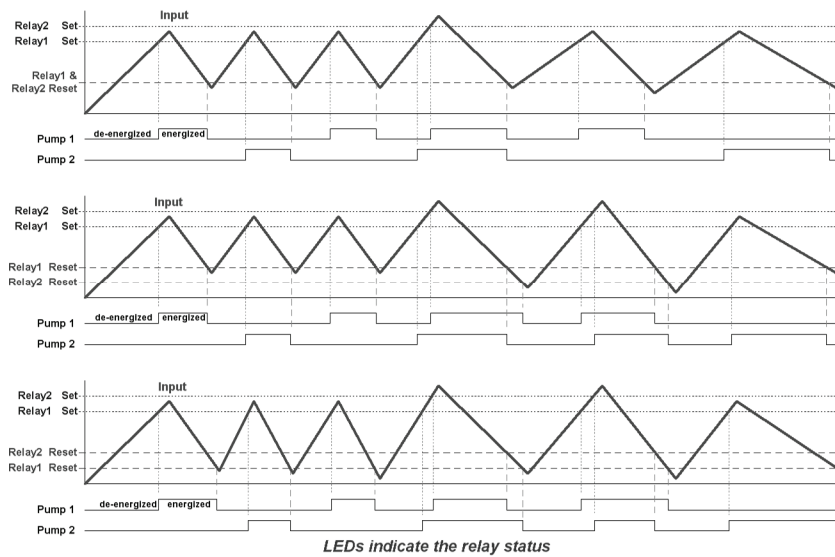

Rate Relay Sampling Operation

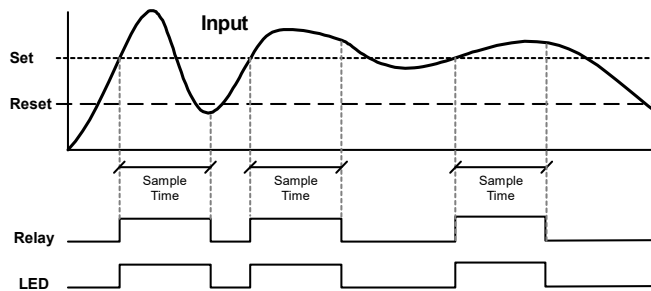

When the signal crosses the set point, the relay trips and the sample time starts. After the sample time has elapsed, the relay resets. The cycle repeats every time the set point is crossed, going up for high alarms and going down for low alarms.

The sample time can be programmed between 0.1 and 5999.9 seconds.

Total Relay Sampling Operation

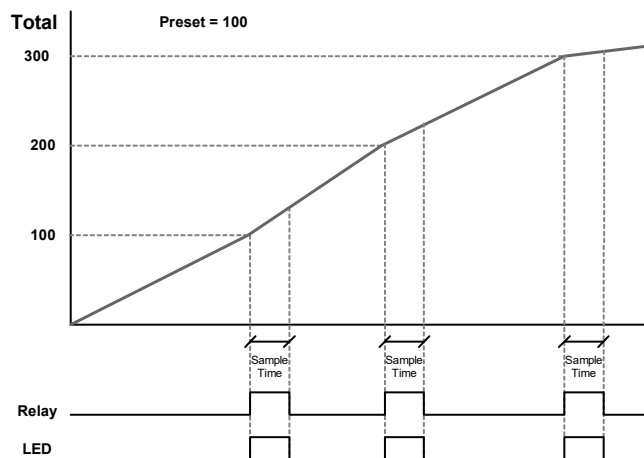

When the total reaches the preset, the relay trips and the sample time starts. After the sample time has elapsed, the relay resets. The cycle repeats every time the preset value is added to the total.

Signal Loss or Loop Break Relay Operation

The following graph shows the loop break operation for a high alarm relay.

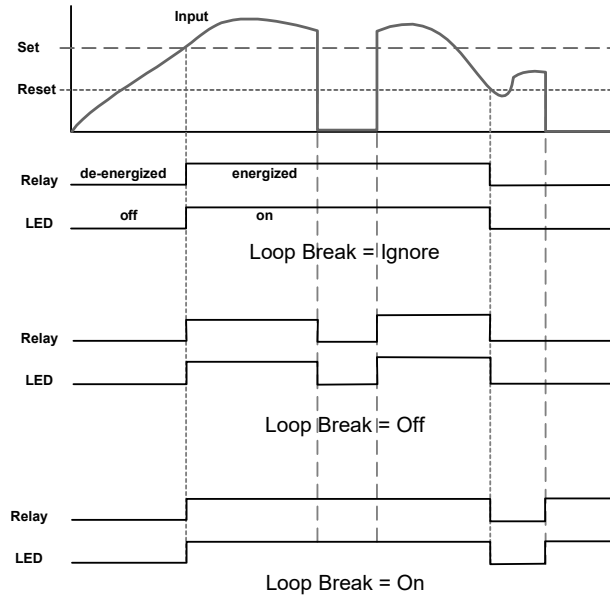

When the meter detects a break in the 4-20 mA loop, the relay will go to one of the following selected actions:

1. Turn on (Go to alarm condition)
2. Turn off (Go to non-alarm condition)
3. Ignore (Process as a low signal condition)

Time Delay Operation

The following graphs show the operation of the time delay function.

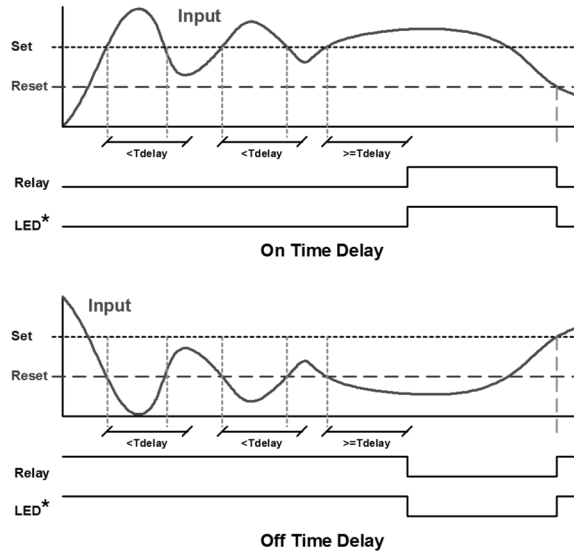

When the signal crosses the set point, the *On* time delay timer starts and the relay trips when the time delay has elapsed. If the signal drops below the set point (high alarm) before the time delay has elapsed, the *On* time delay timer resets and the relay does not change state. The same principle applies to the *Off* time delay.

Note: If "Automatic or Manual (R-rRn)" reset mode is selected, the LED follows the reset point and not the relay state when the relay is acknowledged.

Relay Operation Details

Overview

The relay capabilities of the meter expand its usefulness beyond simple indication to provide users with alarm and control functions. These capabilities include front panel alarm status LEDs as well as either 2 or 4 optional internal relays and/or 4 external relays expansion module. Typical applications include high or low temperature, level, pressure or flow alarms, control applications such as simple on/off pump control, pump alternation control for up to 8 pumps, and basic batch control. There are four basic ways the relays can be used:

1. High or Low Alarms with Latching or Non-Latching Relays
2. Simple On/Off Control with 100% Adjustable Deadband
3. Sampling (Based on Time)
4. Pump Alternation Control for up to 8 Pumps

Relays Auto Initialization

When power is applied to the meter, the front panel LEDs and alarm relays will reflect the state of the input to the meter. The following table indicates how the alarm LEDs and relays will react on power-up based on the set and reset points:

Alarm #	HI or LO Alarm	Set Point	Reset Point	Power-Up Reading	Relay & LED
1	HI	1000	500	499	Off
2	LO	700	900	499	On
3	LO	250	400	499	Off
4	HI	450	200	499	On

Fail-Safe Operation

The following table indicates how the relays behave based on the fail-safe selection for each relay:

Note: NO = Normally Open, NC = Normally Closed. This refers to the condition of the relay contacts when the power to the meter is off.

Fail-Safe Selection	Non-Alarm State		Alarm State		Power Failure
	NO	NC	NO	NC	
Off	Open	Closed	Closed	Open	Relays go to non-alarm state
On	Closed	Open	Open	Closed	Relays go to alarm state

Front Panel LEDs

The LEDs on the front panel provide status indication for the following:

The meter is supplied with four alarm points that include front panel LEDs to indicate alarm conditions. This standard feature is particularly useful for alarm applications that require visual-only indication. The LEDs are controlled by the set and reset points programmed by the user. When the display reaches a set point for a high or low alarm, the corresponding alarm LED will turn on. When the display returns to the reset point the LED will go off. The front panel LEDs respond differently for latching and non-latching relays.

LED	Status
1	Alarm 1
2	Alarm 2
3	Alarm 3
4	Alarm 4

LED	Status
5	Alarm 5
6	Alarm 6
7	Alarm 7
8	Alarm 8

For non-latching relays, the LED is always off during normal condition and always on during alarm condition, regardless of the state of the relay (e.g. Relay acknowledged after alarm condition).

For latching relays, the alarm LEDs reflect the status of the relays, regardless of the alarm condition. The following tables illustrate how the alarm LEDs function in relation to the relays and the acknowledge button (Default: F3 key assigned to ACK):

Latching and Non-Latching Relay Operation

The relays can be set up for latching (manual reset) or non-latching (automatic reset) operation.

The On and Off terminology does not refer to the status of the relay's coil, which depends on the fail-safe mode selected.

Relay terminology for following tables	
Terminology	Relay Condition
On	Alarm (Tripped)
Off	Normal (Reset)
Ack	Acknowledged



Warning! *In latching relay mode, latched relays will reset (unlatch) when power is cycled.*

Non-Latching Relay (Automatic reset)

In this application, the meter is set up for automatic reset (non-latching relay). Acknowledging the alarm while it is still present has no effect on either the LED or the relay. When the alarm finally goes away, the relay automatically resets and the LED also goes off.

Automatic reset only		
Condition	LED	Relay
Normal	Off	Off
Alarm	On	On
Ack (No effect)	On	On
Normal	Off	Off

Non-Latching Relay (Automatic + manual reset)

In this application, the meter is set up for automatic and manual reset at any time (non-latching relay). The LED and the relay automatically reset when the meter returns to the normal condition.

The next time an alarm occurs, the operator acknowledges the alarm manually while the alarm condition still exists. This causes the relay to reset, but the LED stays on until the meter returns to the normal condition.

Automatic + manual reset at any time		
Condition	LED	Relay
Normal	Off	Off
Alarm	On	On
Normal	Off	Off
Next Alarm	On	On
Ack	On	Off
Normal	Off	Off

Latching Relay (Manual reset)

In this application, the meter is set up for manual reset at any time. Acknowledging the alarm even if the alarm condition is still present resets the relay and turns off the LED.

Manual reset any time		
Condition	LED	Relay
Normal	Off	Off
Alarm	On	On
Ack	Off	Off

Latching Relay (Manual reset only after alarm cleared)

In this application, the meter is set up for manual reset only after the signal passes the reset point (alarm condition has cleared). Acknowledging the alarm while it is still present has no effect on either the LED or the relay. When the alarm is acknowledged after it returns to the normal state, the LED and the relay go off. Notice that the LED remains on, even after the meter returns to the normal condition. This is because, for latching relays, the alarm LED reflects the status of the relay, regardless of the alarm condition.

Manual reset only after alarm condition has cleared		
Condition	LED	Relay
Normal	Off	Off
Alarm	On	On
Ack (No effect)	On	On
Normal	On	On
Ack	Off	Off

Acknowledging Relays

There are two ways to acknowledge relays programmed for manual reset:

1. Via the programmable front panel function keys F1-F3 (Default: F3 assigned to ACK).
2. Remotely via a normally open pushbutton wired across one of the digital inputs and the +5 V terminals on the digital I/O modules, or using the F4 digital input, which is triggered with a contact closure to COM, or with an active low signal (see page 15).

When the ACK button or the assigned digital input is closed, all relays programmed for manual reset are acknowledged.

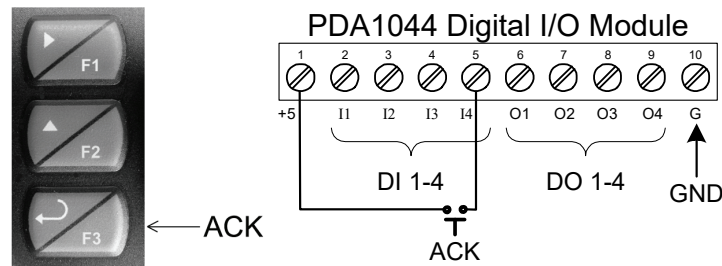

Figure 19: Acknowledge Relays w/Function Key or Digital Input

Pump Alternation Control Applications (RLLErn)

For pump control applications where two or more similar pumps are used to control the level of a tank or a well, it is desirable to have all the pumps operate alternately. This prevents excessive wear and overheating of one pump over the lack of use of the other pumps.

Up to 8 relays can be set up to alternate every time an on/off pump cycle is completed. The set points and reset points can be programmed, so that the first pump on is the first pump off.

Application #1: Pump Alternation Using Relays 1 & 2

1. Relays 1 and 2 are set up for pump alternation.
2. Relays 3 and 4 are set up for low and high alarm indication.

Set and Reset Point Programming

Relay	Set Point	Reset Point	Function
1	30.000	10.000	Controls pump #1
2	35.000	5.000	Controls pump #2
3	4.000	9.000	Controls low alarm
4	40.000	29.000	Controls high alarm

Pump Alternation Operation

1. Pump #1 turns on when level reaches 30.000, when level drops below 10.000 pump #1 turns off.
2. The next time level reaches 30.000, pump #2 turns on, when level drops below 10.000, pump #2 turns off.
3. If the level doesn't reach 35.000, pump #1 and pump #2 will be operating alternately.
4. If pump #1 cannot keep the level below 35.000, pump #2 will turn on at 35.000, then as the level drops to 10.000, pump #1 turns off, pump #2 is still running and shuts off below 5.000.
5. Notice that with the set and reset points of pump #2 outside the range of pump #1, the first pump on is the first pump to go off. This is true for up to 8 alternating pumps, if setup accordingly.
6. Relay #3 will go into alarm if the level drops below 4.000 and relay #4 will go into alarm if the level exceeds 40.000.
7. Adding the 4 external relays expansion module allows using the 4 SPDT internal relays for pump alternation and the 4 SPST external relays for high, high-high, low, and low-low alarm indication.

Application #2: Pump Alternation Using Relays 3 & 4

1. Relays 1 and 2 are set up for low and high alarm indication.
2. Relays 3 and 4 are set up for pump alternation.

Set and Reset Point Programming

Relay	Set Point	Reset Point	Function
1	495	750	Controls low alarm
2	7500	6900	Controls high alarm
3	7000	900	Controls backup pump
4	6000	1000	Controls main pump

The following graphics provide a visual representation of a typical pump alternation application with high and low alarm monitoring:

- Relay #4 turns the main pump on at 6000 gallons and turns it off at 1000 gallons.
- With the Pump Alternation feature activated, the next time the level reaches 6000 gallons, relay #3 transfers and starts the backup pump.
- If the backup pump is not able to keep up, and the level reaches 7000 gallons, relay #4 transfers and starts the main pump as well.
- Relay #2 trips the High Level Alarm at 7500 gallons and resets at 6900 gallons.
- Relay #1 trips the Low Level Alarm at 495 gallons and resets at 750 gallons.

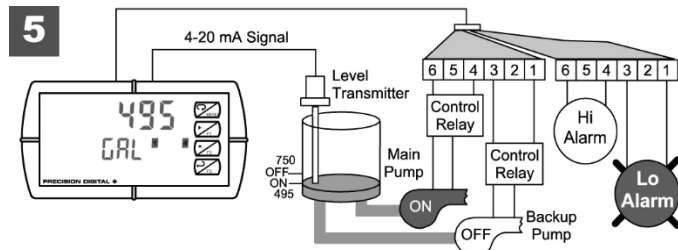
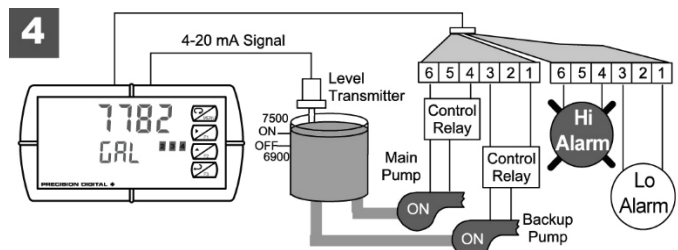
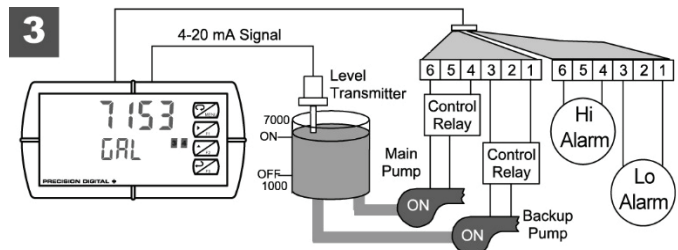
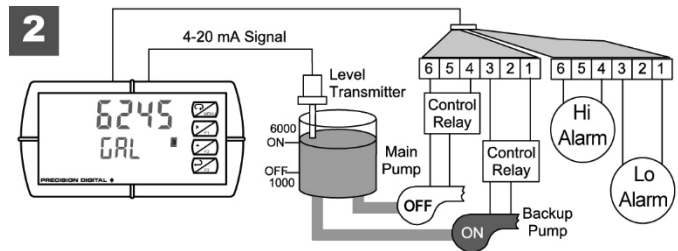
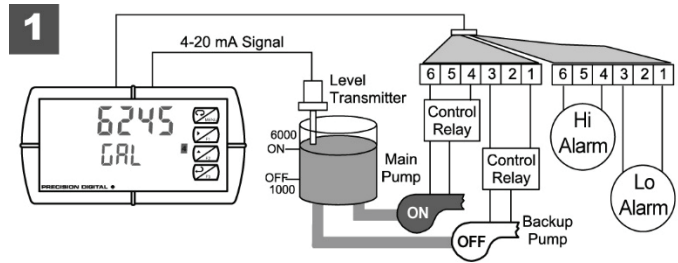

Setting Up the Interlock Relay (Force On) Feature

Relays 1-4 can be set up as interlock relays. To set up the relays for the interlock feature:

1. Access the *Setup – Relay – Action* menu and set the action to off.

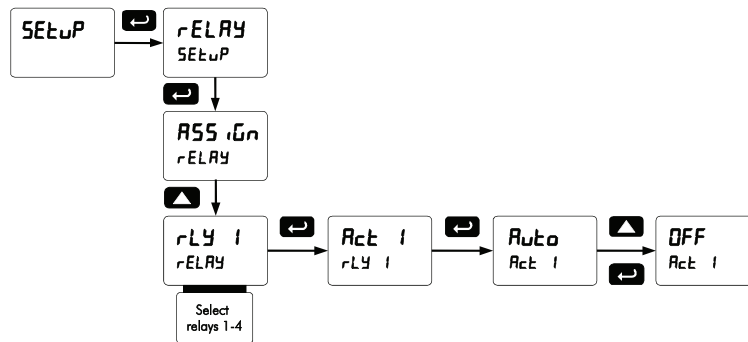

2. In the Advanced features – *User* menu program any of the digital inputs to *Force On* any of the internal relays (1-4).

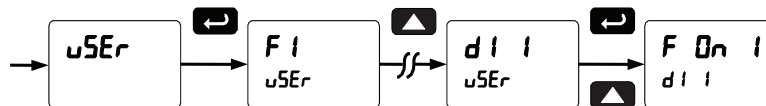

3. Connect a switch or dry contact between the +5V terminal and the corresponding digital input (di-1 to di-4) terminal.

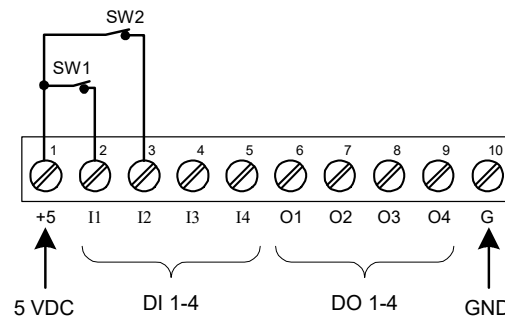

Interlock Relay Operation Example

Relays 1 & 2 are configured to energize (their front panel LEDs are off) when SW1 & SW2 switches (above) are closed. If the contacts to these digital inputs are opened, the corresponding front panel LEDs flash indicating this condition. The processes being controlled by the interlock relay will stop, and will restart only after the interlock relay is re-activated by the digital inputs (switches).

Note: If multiple digital inputs are assigned to the same relay, then the corresponding logic is (AND) – i.e. both switches must be closed to trip the relay.

Scaling the 4-20 mA Analog Output (Rout)

The 4-20 mA analog output can be scaled to provide a 4-20 mA signal for any display range selected. No equipment is needed to scale the analog output; simply program the display values to the corresponding mA output signal.

The *Analog Output* menu is used to program the 4-20 mA output based on display values.

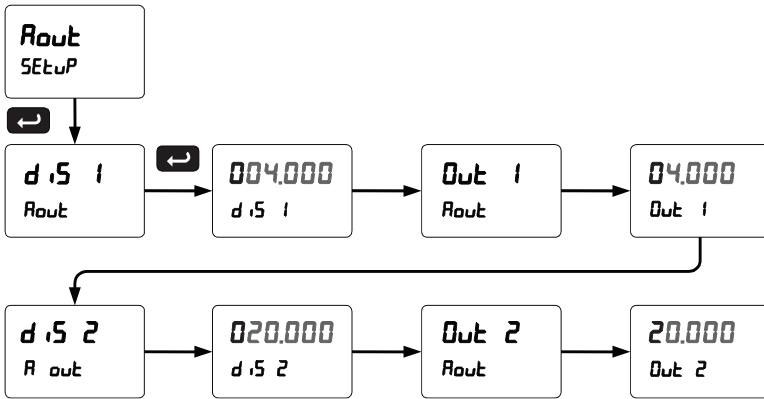

For instructions on how to program numeric values see *Setting Numeric Values*, page 21.

Reset Menu (rESEt)

The *Reset* menu is used to reset the totals and maximum or minimum reading (peak or valley) reached by the process; both may be reset at the same time by selecting “reset high & low” (rSE HL). If *total* is set to *no*, the tare value used to zero the display may be reset by selecting “reset tare” (rSE tr).

Control Menu (Contrl)

The *Control* menu is used to control the 4-20 mA analog output and the relays manually, ignoring the input. Each relay and analog output can be programmed independently for manual control. Selecting automatic control sets all relays and analog output for automatic operation.

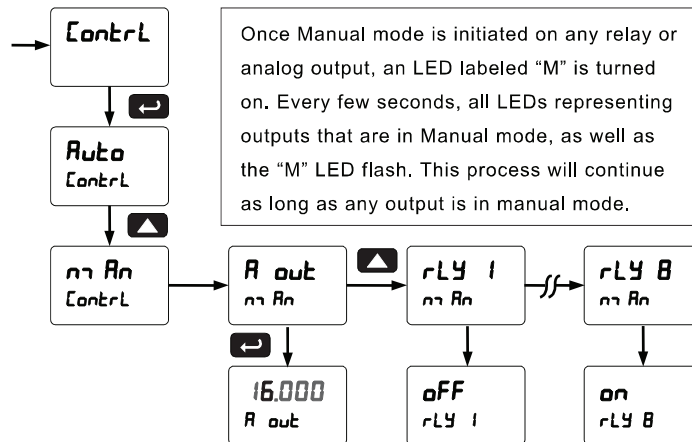

Once Manual mode is initiated on any relay or analog output, an LED labeled “M” is turned on. Every few seconds, all LEDs representing outputs that are in Manual mode, as well as the “M” LED flash. This process will continue as long as any output is in manual mode.

Setting Up the Password (PASS)

The *Password* menu is used for programming three levels of security to prevent unauthorized changes to the programmed parameter settings and to program the non-resettable totalizer.

Pass 1: Allows use of function keys and digital inputs
 Pass 2: Allows use of function keys, digital inputs and editing set/reset points
 Pass 3: Restricts all programming, function keys, and digital inputs.
 Total: Prevents resetting the total manually
 Gtotal: Prevents resetting the grand total manually

Protecting or Locking the Meter

Enter the *Password* menu and program a six-digit password.

For instructions on how to program numeric values see *Setting Numeric Values*, page 21.

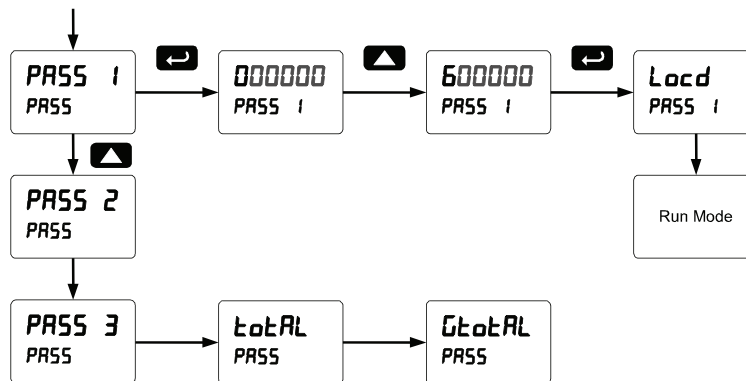

Total Reset Password & Non-Resettable Total

The total and the grand total can be password-protected to prevent unauthorized total resets.

The grand total can be programmed as a non-resettable total by entering the password “050873”.

Caution! *Once the Grand Total has been programmed as “non-resettable” the feature **cannot** be disabled.*

Making Changes to a Password Protected Meter

If the meter is password protected, the meter will display the message *L o c d* (*Locked*) when the Menu button is pressed. Press the Enter button while the message is being displayed and enter the correct password to gain access the menu. After exiting the programming mode, the meter returns to its password protected condition.

Disabling Password Protection

To disable the password protection, access the *Password* menu and enter the correct password twice, as shown below. The meter is now unprotected until a new password is entered.

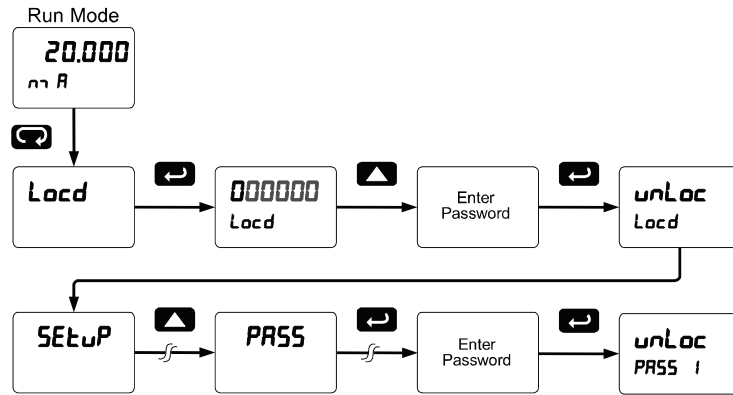

If the correct six-digit password is entered, the meter displays the message *unLoc* (unlocked) and the protection is disabled until a new password is programmed.

If the password entered is incorrect, the meter displays the message *L o c d* (*Locked*) for about two seconds, and then it returns to Run Mode. To try again, press Enter while the *Locked* message is displayed.

Did you forget the password?

The password may be disabled by entering a master password once. If you are authorized to make changes, enter the master password 508655 to unlock the meter.

Advanced Features Menu

To simplify the setup process, functions not needed for most applications are located in the *Advanced Features* menu.

Press and hold the Menu button for three seconds to access the advanced features of the meter.

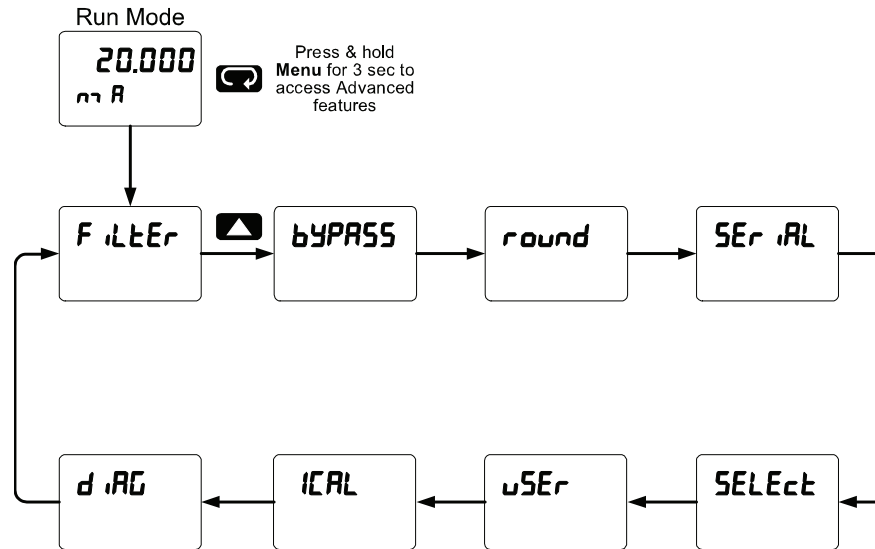

Advanced Features Menu & Display Messages

The following table shows the functions and messages of the *Advanced Features* menu in the order they appear in the menu.

Display	Parameter	Action/Setting
F iLtEr	Filter	Set noise filter value
bYPASS	Bypass	Set filter bypass value
round	Round	Set the rounding value for display variables
SEr iAL	Serial	Set serial communication parameters
SLAVE Id	Slave ID	Set slave ID or meter address
bAud	Baud rate	Select baud rate
tr dLY	Transmit delay	Set transmit delay for serial communication
PRr iLY	Parity	Select parity Even, Odd, or None with 1 or 2 stop bits
t-byt	Time byte	Set byte-to-byte timeout
SELEct	Select	Enter the Select menu (function, cutoff, out)
FuncTn	Signal input conditioning	Select linear, square root, programmable exponent, or round horizontal tank function
LiNEAr	Linear	Set meter for linear function and select number of linearization points

Display	Parameter	Action/Setting
no PtS	Number of points	Set meter for 2 to 32-point linearization
SqURrE	Square root	Set meter for square root extraction
PrOG E	Programmable exponent	Set meter for programmable exponent and enter exponent value
rhE	Round horizontal tank	Set meter for round horizontal tank volume calculation
inch	Dimension(cm)	Calculate volume in gallons or meters
d iAMr r	Diameter	Enter the tank's diameter in inches
LEnGth	Length	Enter the tank's length in inches
CuTOFF	Cutoff	Set low-flow cutoff
CounT	Count	Set total and grand total count direction
tot E	Total Count	Set total to count up or down
GrTot E	Grand Total Count	Set grand total to count up or down
E StErT	Count Start	Set start for total or grand total countdown

Display	Parameter	Action/Setting
RoUtPr	Analog output programming	Program analog output parameters
Source	Source	Select source for the 4-20 mA output
OverRng	Overrange	Program mA output for display overrange
Underrng	Underrange	Program mA output for display underrange
brERH	Loop Break	Set relay condition if loop break detected
Force	Force	Force analog output value for loop break
Ignore	Ignore	Ignore loop break condition
MaxRH	Maximum	Program maximum mA output allowed
MinRn	Minimum	Program minimum mA output allowed
CRl b	Calibrate	Calibrate 4-20 mA output (internal reference source used for scaling the output)
4 mR	4 mA output	Enter mA output value read by milliamp meter with at least 0.001 mA resolution
20 mR	20 mA output	Enter mA output value read by milliamp meter with at least 0.001 mA resolution
uSEr	User I/O	Assign function keys and digital I/O
F1	F1 function key	Assign F1 function key
F2	F2 function key	Assign F2 function key

Display	Parameter	Action/Setting
F3	F3 function key	Assign F3 function key
F4	F4 function	Assign F4 function (digital input)
d i i	Digital input 1	Assign digital input 1 – 8, if expansion modules are connected
dO i	Digital output 1	Assign digital output 1 – 8, if expansion modules are connected
iCRl	Internal source calibration	Enter internal source calibration (used for scaling the meter without a signal source)
CRl	Current calibration	Calibrating 4-20 mA current input (internal reference source used for scaling the input)
CRl o	Current low	Calibrate low current input (e.g. 4 mA)
CRl h	Current high	Calibrate high current input (e.g. 20 mA)
vCRl	Voltage calibration	Calibrating voltage input
vCRl o	Voltage low	Calibrate low voltage input (e.g. 0 V)
vCRl h	Voltage high	Calibrate high voltage input (e.g. 10 V)
d iAG	Diagnostics	Display parameter settings
LEd t	LED test	Test all LEDs
InfO	Information	Display software and S/N information
ErRSE	Erase	Erase MeterView Pro software stored in meter's memory

Noise Filter (FiltEr)

The noise filter is available for unusually noisy signals that cause an unstable process variable display. The noise filter averages the input signal over a certain period. The filter level determines the length of time over which the signal is averaged. The filter level can be set between 2 and 199. The higher the filter level, the longer the averaging time and so the longer it takes the display to settle to its final value. Setting the filter level to zero disables the filter function.

Noise Filter Bypass (bYPASS)

The noise filter bypass changes the behavior of the meter so that small variations in the signal are filtered out but large abrupt changes in the input signal are displayed immediately. The bypass value determines the minimum amount of signal change to be displayed immediately. All signal changes smaller than the bypass value are filtered or averaged by the meter. The noise filter bypass may be set between 0.1 and 99.9% of full scale.

Rounding Feature (*round*)

The rounding feature is used to give the user a steadier display with fluctuating signals. Rounding is used in addition to the filter function.

Rounding causes the display to round to the nearest value according the rounding selected. See examples below:

Rounding Selection	Actual Value	Display Value	Actual Value	Display Value
1	12.022	12.022	12.023	12.023
5	12.022	12.020	12.023	12.025
10	12.024	12.020	12.025	12.030

Modbus RTU Serial Communications (*SEr ,iRL*)

The meter is equipped with serial communications capability as a standard feature using Modbus RTU Serial Communication Protocol.

The meter may be connected to a PC for initial configuration via the onboard micro USB connection. For ongoing digital communications with a computer or other data terminal equipment, an RS-232, or RS-485 option is required; see *Ordering Information* on page 5 for details.



Warning! *Do not connect any equipment other than Precision Digital's expansion modules, cables, or meters to the RJ45 M-LINK connector. Otherwise damage will occur to the equipment and the meter.*

Note: More detailed instructions are provided with each optional serial communications adapter.

Note: Refer to the PROVu® Modbus Register Tables located at www.predig.com for details.

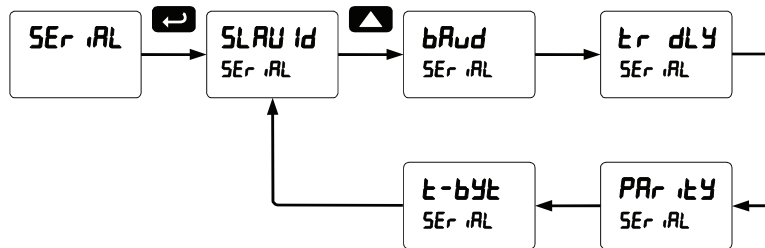

When using more than one meter in a multi-drop mode, each meter must be provided with its own unique address. The meter address (Slave ID) may be programmed between 1 and 247. The transmit delay may be set between 0 and 199 ms. The parity can be set to even, odd, or none with 1 or 2 stop bits.

Select Menu (SELEct)

The *Select* menu is used to select the signal input conditioner applied to the input (linear, square root, programmable exponent, or round horizontal tank), low-flow cutoff, and analog output programming. The multi-point linearization is part of the linear function selection.

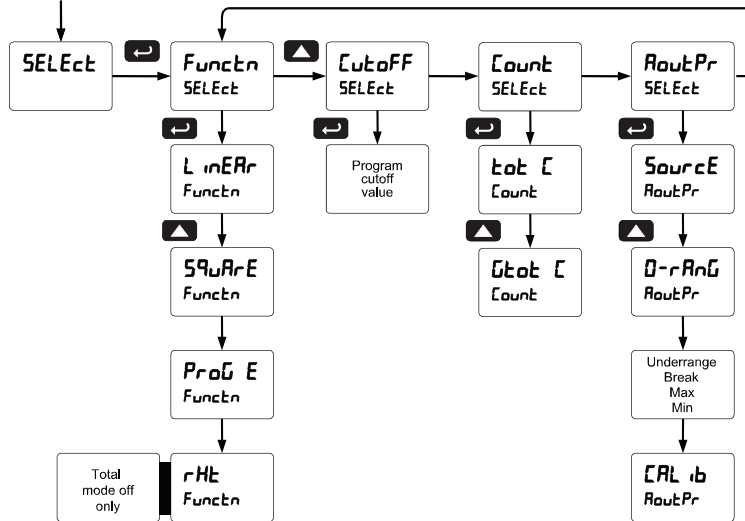

Signal Input Conditioning (Functn)

The *Function* menu is used to select the signal input conditioner applied to the input: linear, square root, programmable exponent, or round horizontal tank volume calculation. The multi-point linearization is part of the linear function selection.

Meters are set up at the factory for linear function with 2-point linearization. The linear function provides a display that is linear with respect to the input signal.

Multi-Point Linearization (L inERr)

Meters are set up at the factory for linear function with 2-point linearization. Up to 32 linearization points can be selected under the linear function. The multi-point linearization can be used to linearize the display for non-linear signals such as those from level transmitters used to measure volume in odd-shaped tanks or to convert level to flow using weirs and flumes with complex exponent.

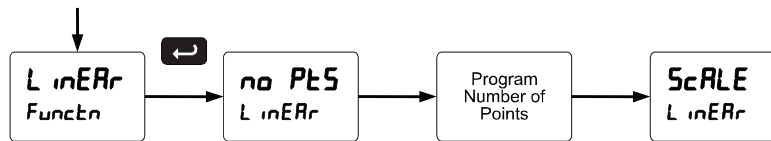

Square Root Linearization (SQURrE)

The square root function can be used to linearize the signal from a differential pressure transmitter and display flow rate in engineering units.

Programmable Exponent Linearization (ProG E)

The programmable exponent can be used to linearize the signal from level transmitters in open-channel flow applications using weirs and flumes.

Round Horizontal Tank Linearization (rHt)

This function automatically calculates the volume in a round horizontal tank with flat ends. This function is only used when *Unit RL* is set to *rod*.

Set the display for the desired decimal point and engineering units before entering the round horizontal tank function. Select units, inches or cm for the tank dimension. Enter the diameter and the length in inches and the results are given in US gallons.

The meter can be scaled to display the volume in any engineering unit.

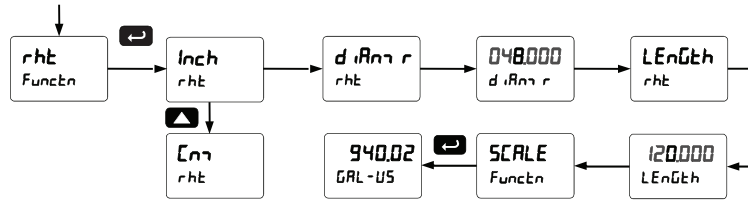

Note: After Scale is displayed continue pressing the Enter button until the meter completes the scaling of the input and display values.

Changing the Volume from Gallons to Liters

In the above graphic, entering the 48" for the diameter and 120" for the length of the round horizontal tank, the meter automatically calculates that the volume of the tank is 940.02 gallons.

1. Convert gallons to liters
 1 US gallon = 3.7854 L
 940.02 gal = 3558.4 L
2. Go to the *Setup* menu and change the decimal point to 1 decimal.
3. Go to the *Program – Scale* menu and press Enter until *d .5 2* is shown on the main display.
4. Press Enter and change the display 2 value to 3558.4.
5. The meter is now displaying the volume in liters.

Note: The display can be scaled to display the volume in any engineering units.

Low-Flow Cutoff (LktoFF)

The low-flow cutoff feature allows the meter to be programmed so that the often-unsteady output from a differential pressure transmitter, at low flow rates, always displays zero on the meter.

The cutoff value may be programmed from 0 to 999999. The meter will display zero below the cutoff value. Programming the cutoff value to zero disables the cutoff feature.

Totalizer Count Up/Down (Count)

The totalizer count up/down menu may be used to program the total and grand total to either count up from 0 when reset or count down from a programmed value when reset. Total and grand total may have their countdown numbers programmed individually from 0 to 999999.

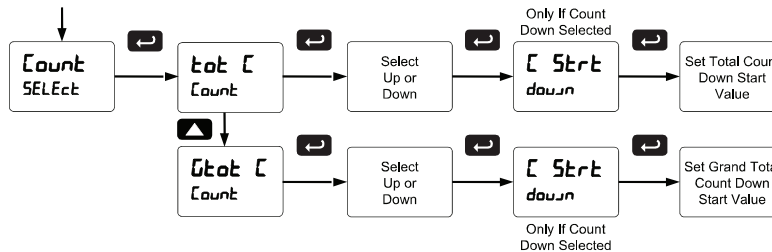

Analog Output Programming (RoutPr)

The *Analog Output Programming* menu is used to program the behavior of the 4-20 mA output. The following parameters and functions are programmed in this menu:

1. Source: Source for generating the 4-20 mA output (e.g. PV)
2. Overrange: Analog output value with display in overrange condition
3. Underrange: Analog output value with display in underrange condition
4. Break: Analog output value when loop break is detected
5. Max: Maximum analog output value allowed regardless of input
6. Min: Minimum analog output value allowed regardless of input
7. Calibrate: Calibrate the internal 4-20 mA source reference used to scale the 4-20 mA output

Analog Output Source

The source for generating the 4-20 mA output may be assigned to the rate/process variable, total, grand total, maximum or minimum value reached by the rate/process, or one of the set points, or the Modbus PV input.

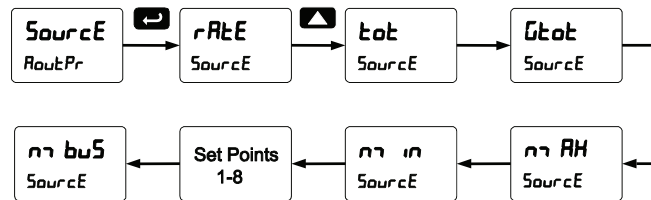

Analog Output Calibration

To perform the analog output calibration, it's recommended to use a milliamp meter with a resolution of at least 0.1 μ A to measure the output current. The values saved internally during this procedure are used for scaling the 4-20 mA output in the *Setup* menu.

Programmable Function Keys User Menu (uSEr)

The *User* menu allows the user to assign the front panel function keys F1, F2, and F3, the digital input F4 (a digital input located on the signal input connector), and up to eight additional digital inputs to access most of the menus or to activate certain functions immediately (e.g. reset max & min, hold relay states, etc.). This allows the meter to be greatly customized for use in specialized applications.

Up to eight digital outputs can be assigned to a number of actions and functions executed by the meter (i.e. alarms, relay acknowledgement, reset max, min, or max & min, tare, and reset tare). The digital outputs can be used to trigger external alarms or lights to indicate these specific events.

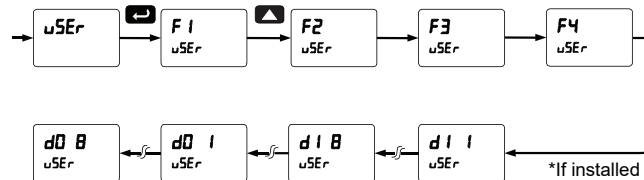

Function Keys & Digital I/O Available Settings

Refer to the following table for descriptions of each available function key or digital I/O setting.

Display	Description
rELRY	Directly access the relay menu
SEt <input type="checkbox"/>	Directly access the set point menu for relay 1 (*through 8)
rLY d	Disable all relays until a button assigned to <i>enable relays (rLY E)</i> is pressed
rLY E	Enable all relays to function as they have been programmed
0 Hold	Hold current relay states and analog output as they are until a button assigned to <i>enable relays (rLY E)</i> is pressed
d Hold	Hold the current display value, relay states, and analog output momentarily while the function key or digital input is active. The process value will continue to be calculated in the background.
Ln1 Hi	Display maximum display value on line 1
Ln1 Lo	Display minimum display value on line 1
Ln1 HL	Display maximum & minimum display values on line 1
Ln2 Hi	Display maximum display value on line 2
Ln2 Lo	Display minimum display value on line 2
Ln2 HL	Display maximum & minimum display values on line 2
Ln2 Gt	Display the grand total on line 2

Display	Description
F On <input type="checkbox"/>	Force relay 1 (*through 4) into the on state. This function is used in conjunction with a digital input expansion module to achieve interlock functionality. See page 38 for details about interlock relays.
Control	Directly access the control menu
d,SRbL	Disable the selected function key or digital I/O
RcH	Acknowledge all active relays that are in a manual operation mode such as auto-manual or latching
rESEt	Directly access the reset menu
rSt t	Reset the total
rSt Gt	Reset the grand total
rSt Hi	Reset the stored maximum display value
rSt Lo	Reset the stored minimum display value
rSt HL	Reset the stored maximum & minimum display values
nrEnu	Mimic the menu button functionality (digital inputs only)
rRt	Mimic the right arrow/F1 button functionality (digital inputs only)
uP	Mimic the up arrow/F2 button functionality (digital inputs only)
EntEr	Mimic the enter/F3 button functionality (digital inputs only)
RLn1 <input type="checkbox"/>	Provide indication when alarm 1 (*through 8) has been triggered (digital outputs only)

Internal Source Calibration (ICAL)

The meter is factory calibrated prior to shipment to read in milliamps and volts, depending on the input selection. The calibration equipment is certified to NIST standards.

The use of calibrated signal sources is necessary to calibrate the internal source of the meter. The meter's internal source is what allows the user to scale the meter without applying a signal.

Check calibration of the meter at least every 12 months. Each input must be recalibrated separately.

Notes:

1. If meter is in operation and it is intended to accept only one input type (e.g. 4-20 mA), recalibration of other input is not necessary.
2. Allow the meter to warm up for at least 15 minutes before performing the internal source calibration procedure.

The *Internal calibration* menu is part of the *Advanced Features* menu.

1. Press and hold the Menu button for three seconds to access the advanced features of the meter.
2. Press the Up arrow button to scroll to the *Internal calibration* menu (ICAL) and press Enter.
3. The meter displays either current calibration (ICAL) or voltage calibration (VICAL), according to the input setup. Press Enter to start the calibration process.

Example of Internal Calibration for current input:

4. The meter displays *low* input current message (CLo). Apply the low input signal and press Enter. The display flashes for a moment while the meter is accepting the low input signal.
5. After the display stops flashing, a number is displayed with the leftmost digit brighter than the rest. The bright digit is the active digit that can be changed by pressing the Up arrow button. Press the Right arrow button to move to the next digit.
6. Set the display value to correspond to the input signal being calibrated, typically 4.000 mA.
7. The display moves to the *high* input calibration (CHi). Apply the high input signal and press Enter.
8. Set the display for the high input calibration, in the same way as it was set for the low input calibration, typically 20.000 mA.

The graphic shows the calibration of the current input. The voltage input is calibrated in a similar way.

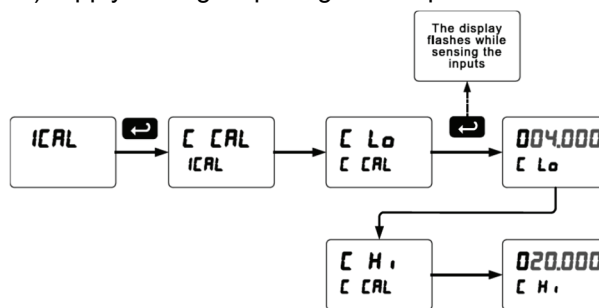

Tips:

- Low and high input signals can be any valid values within the range of the meter.
- Observe minimum input span requirements between input 1 and input 2.
- Low input should be less than high input signal.

Error Message (Error)

An error message indicates that the calibration or scaling process was not successful.

After the error message is displayed, the meter reverts to the input prior to the failure during calibration or scaling and to input 1 during internal calibration, allowing the appropriate input signal to be applied or programmed.

The error message might be caused by any of the following conditions:

1. Input signal is not connected to the proper terminals or it is connected backwards.
2. Wrong signal selection in **Setup menu**.
3. Minimum input span requirements not maintained.

Input 1 signal inadvertently applied to calibrate input 2.

Minimum Input Span

The minimum input span is the minimum difference between input 1 and input 2 signals required to complete the calibration or scaling of the meter.

Input range	Input 1 & input 2 span
4-20 mA	0.15 mA
±10 VDC	0.01 VDC

Meter Operation

The meter is capable of accepting current (0-20 mA, 4-20 mA) and voltage signals (0-5 V, 1-5 V, 0-10 V, ± 10 V) and displaying these signals in engineering units from -99999 to 999999 (e.g. a 4-20 mA signal could be displayed as -50.000 to 50.000).

The dual-line display can be customized by the user to operate in such a way as to satisfy a specific application. Typically, the main display is used for the process variable; while the second display is used for engineering units, custom legend, total, grand total, or set point indication.

The meter can be set up to display the analog input on the main display and the Modbus input on the second display. The relays and analog output can be programmed to operate from the Modbus PV input.

Front Panel Buttons Operation

Button Symbol	Description
	Press to enter or exit Programming Mode, view settings, or exit max/min readings
	Press to reset max/min readings or other parameter/function assigned through the <i>User</i> menu
	Press to display max/min readings or other parameter/function assigned through the <i>User</i> menu
	Press to acknowledge relays or other parameters/function assigned through the <i>User</i> menu

Function Keys Operation

During operation, the programmable function keys operate according to the way they have been programmed in the *Advanced Features – User* menu.

The table above shows the factory default settings for F1, F2, and F3.

F4 Operation

A digital input, F4, is standard on the meter. This digital input is programmed identically to function keys F1, F2, and F3. The input is triggered with a contact closure to COM, or with an active low signal. During operation, F4 operates according to the way it has been programmed in the *Advanced Features – User* menu.

Maximum/Minimum Readings

The max & min readings (peak & valley) reached by the process can be displayed either continuously or momentary:

1. Display briefly by assigning to the F1-F3 function keys or to the digital inputs in the *User* menu.
2. Display continuously by assigning either display to max/min through the *Display* menu.

Any of the F1-F3 function keys (buttons) and the digital inputs can be programmed to reset the max & min readings. The meters are set at the factory to display the max reading by pressing the Up arrow/F2 button and to use the Right arrow/F1 button to access the *Reset* menu.

To display max reading using function key with factory defaults:

1. Press Up arrow/F2 button to display maximum reading since the last reset/power-up.
2. To reset max/min press Right arrow/F1 button to access the Reset menu. The max & min displays are reset to actual values.
3. Press Menu to exit max/min display reading.

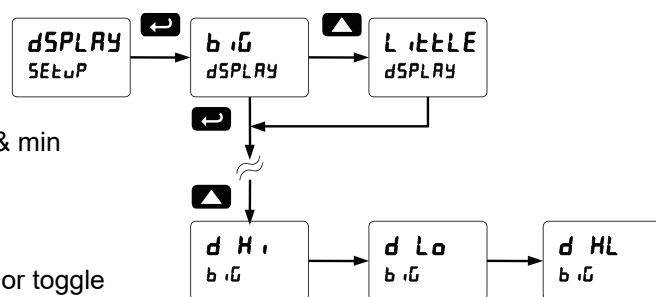

To display max/min readings continuously:

Assign either display to Max (*d H i*), Min (*d L o*), or toggle between Max and Min (*d H L*) every 10 seconds.

Troubleshooting

Due to the many features and functions of the meter, it's possible that the setup of the meter does not agree with what an operator expects to see.

If the meter is not working as expected, refer to the *Diagnostics* menu and recommendations below.

Diagnostics Menu (d iRG)

The *Diagnostics* menu is located in the *Advanced Features* menu, to access *Diagnostics* menu see *Advanced Features Menu*, page 42.

This menu allows the user to test the functionality of all the meter LEDs, check the meter's software and version information, and erase the MeterView Pro software installation files from the meter. Press the Enter button to view the settings and the Menu button to exit at any time.

For a description of the diagnostic messages, see *Advanced Features Menu & Display Messages*, page 42.

Determining Software Version

To determine the software version of a meter:

1. Go to the *Diagnostics* menu (d iRG) and press Enter button.
2. Press Up arrow button and scroll to Information menu (InFa).
3. Press Enter to access the software number (5Fl) and version (LiEr) information. Write down the information as it is displayed. Continue pressing Enter until all the information is displayed.
4. The meter returns to Run Mode after displaying all the settings.

Reset Meter to Factory Defaults

When the parameters have been changed in a way that is difficult to determine what's happening, it might be better to start the setup process from the factory defaults.

Instructions to load factory defaults:

1. Enter the *Advanced Features* menu. See *Advanced Features Menu*, page 42.
2. Press Up arrow to go to *Diagnostics* menu
3. Press and hold Right arrow for three seconds, press Enter when display flashes rESEt.
Note: If Enter is not pressed within three seconds, the display returns to the *Diagnostics* menu.
4. The meter goes through an initialization sequence (similar as on power-up), and loads the factory default settings.

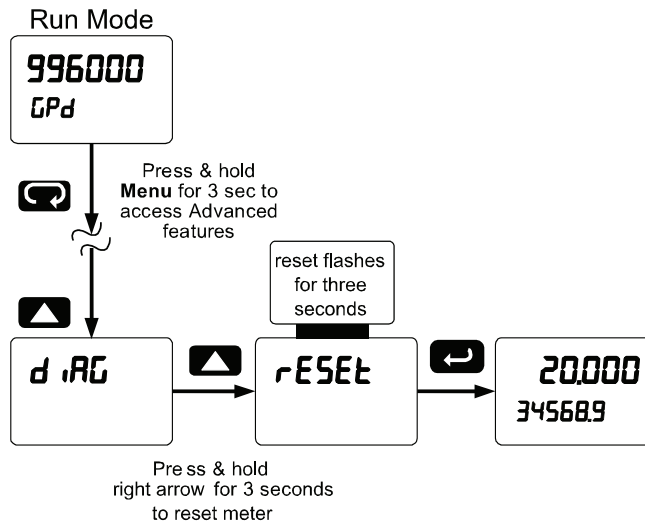

Factory Defaults & User Settings

The following table shows the factory setting for most parameters.

Parameter	Display	Default Setting	Parameter	Display	Default Setting
Input type	INPut	4-20 mA	Relay 4 assignment	RS iLn4	Rate
Total	toLR	Yes	Relay 1 action	Rct 1	Automatic
Units	units	Rate / total / gr. total mA / mA / mA	Relay 1 set point	SEt 1	1.000
Filter	FiLTER	70	Relay 1 reset point	rSt 1	0.000
Bypass	bYPASS	0.2	Relay 2 action	Rct 2	Automatic
Function	FunctiOn	Linear	Relay 2 set point	SEt 2	2.000
Number of points	no Pts	2	Relay 2 reset point	rSt 2	0.000
Programming	PrOg	Scale	Relay 3 action	Rct 3	Automatic
Input 1	INP 1	4.000 mA	Relay 3 set point	SEt 3	3.000
Display 1	d.iS 1	4.000	Relay 3 reset point	rSt 3	2.500
Input 2	INP 2	20.000 mA	Relay 4 action	Rct 4	Automatic
Display 2	d.iS 2	20.000	Relay 4 set point	SEt 4	4.000
Decimal point	ddd.ddd	3 places	Relay 4 reset point	rSt 4	3.500
Cutoff value	CuTOff	0.000 (disabled)	Fail-safe relay 1	FLS 1	Off
Display line 1	LiNE 1	Rate/Process	Fail-safe relay 2	FLS 2	Off
Display line 2	LiNE 2	Total value	Fail-safe relay 3	FLS 3	Off
Display intensity	d-intY	8	Fail-safe relay 4	FLS 4	Off
Total time base	t tb	Second	Display 1 analog out	d.iS 1	4.000
Total conversion factor	t CF	1.000	Output 1 value	Out 1	4.000 mA
Total reset	t rSt	Manual	Display 2 analog out	d.iS 2	20.000
Grand total time base	Gt tb	Second	Output 2 value	Out 2	20.000 mA
Grand total conversion factor	Gt CF	1.000	Source analog output	Source	Rate/process
Grand total reset	Gt rSt	Manual	Ovrrange output	U-rAnG	21.000 mA
Total count up/down	toLR	Up	Underrange output	u-rAnG	3.000 mA
Grand tot count	GtoLR	Up	Loop break output	brERH	1.000 mA
Relay 1 assignment	RS iLn 1	Total	Maximum output	nr RH	23.000 mA
Relay 2 assignment	RS iLn 2	Total	Minimum output	nr n	1.000 mA
Relay 3 assignment	RS iLn 3	Rate	F1 function key	F 1	Reset max & min

Parameter	Display	Default Setting	Parameter	Display	Default Setting
Password 1	PR55 1	000000 (unlocked)	Total password	ŁŁŁŁŁŁ	000000 (unlocked)
Password 2	PR55 2	000000 (unlocked)	Grand total password	ŁŁŁŁŁŁ	000000 (unlocked)
Password 3	PR55 3	000000 (unlocked)			

Troubleshooting Tips

Symptom	Check/Action
No display at all	Check power at power connector
Not able to change setup or programming, ŁŁŁŁ is displayed	Meter is password-protected, enter correct six-digit password to unlock
Meter displays error message during calibration (Error)	Check: 1. Signal connections 2. Input selected in Setup menu 3. Minimum input span requirements
Meter displays 999999 -999999	Check: 1. Input selected in Setup menu 2. Corresponding signal at Signal connector
Display is unstable	Check: 1. Input signal stability and value 2. Display scaling vs. input signal 3. Filter and bypass values (increase)
Display response is too slow	Check filter and bypass values
Display reading is not accurate	Check: 1. Signal input conditioner selected: Linear, square root, etc. 2. Scaling or calibration
Display does not respond to input changes, reading a fixed number	Check: Display assignment, it might be displaying max, min, or set point.
Display alternates between 1. H Ł and a number 2. ŁŁ and a number	Press Menu to exit max/min display readings.
Relay operation is reversed	Check: 1. Fail-safe in Setup menu 2. Wiring of relay contacts
Relay and status LED do not respond to signal	Check: 1. Relay action in Setup menu 2. Set and reset points
Flashing relay status LEDs	Relays in manual control mode or relay interlock switches opened.
Meter not communicating with application programs	Check: 1. Serial adapter and cable 2. Serial settings 3. Meter address and baud rate
If the display locks up or the meter does not respond at all	Cycle the power to reboot the microprocessor.
Other symptoms not described above	Call Technical Support for assistance.

Note: Certain sequences of events can cause unexpected results. To solve these issues, it is best to start fresh from factory defaults and map changes ahead of time, rather than at random.

This Page Intentionally Left Blank



EU Declaration of Conformity

Issued in accordance with ISO/IEC 17050-1:2004.

We,

Precision Digital Corporation
233 South Street
Hopkinton, MA 01748 USA

as the manufacturer, declare under our sole responsibility that the product(s),

Model PD6200 ProVu Series Analog Rate/Totalizer

to which this declaration relates, is in conformity with the European Union Directives shown below:

2014/35/EU	Low Voltage Directive
2014/30/EU	EMC Directive
2011/65/EU	RoHS Directive

This conformity is based on compliance with the application of harmonized or applicable technical standards and, when applicable or required, a European Union notified body certification.

Standards:

EN 55022:2003
EN 61000-6-2:2001
EN 61010-1:2001
EN 61326:2006

The standards EN 55022:2003, EN 61000-6-2:2001, EN 61010-1:2001, and EN 61326:2006 are no longer harmonized. The requirements of these standards have been checked against the harmonized standards EN 55022:2010, EN 61000-6-2:2005, EN 61010-1:2010, and EN 61326:2013 and there were no major technical changes affecting the latest technical knowledge for the products listed above.

Product Markings:



Signed for and on behalf of Precision Digital Corporation:

Name: Jeffrey Peters
Company: Precision Digital Corporation
Title: President
Date: 04/20/2016

Document No: DoC PD6200 {042016}

How to Contact Precision Digital

- For Technical Support, please
Call: (800) 610-5239 or (508) 655-7300
Fax: (508) 655-8990
Email: support@predig.com
- For Sales Support or to place an order, please contact your local distributor or
Call: (800) 343-1001 or (508) 655-7300
Fax: (508) 655-8990
Email: sales@predig.com
- For the latest version of this manual please, visit www.predig.com

PRECISION DIGITAL CORPORATION

233 South Street • Hopkinton MA 01748 USA
Tel (800) 343-1001 • Fax (508) 655-8990



www.predig.com