

**Operating Instructions
for
Screw-Volumeter**

Model: OMG



1. Contents

1. Contents.....	2
2. Note	3
3. Instrument Inspection.....	3
4. Regulation Use	4
5. Operating Principle.....	4
6. General Information	4
7. Warranty	5
8. Mechanical Connection.....	5
9. Electrical Connection	6
10. Start up	7
11. Dismounting and Mounting	7
12. Failure	14
13. Maintenance	15
14. Technical Information.....	15
15. Order Codes	17
16. Dimensions and weights	18
17. Pressure loss diagram	20
18. Disposal	21
19. Manufacturer's declaration.....	22
20. EU Declaration of conformance	23

Manufactured and sold by:

Kobold Messring GmbH
Nordring 22-24
D-65719 Hofheim
Tel.: +49(0)6192-2990
Fax: +49(0)6192-23398
E-Mail: info.de@kobold.com
Internet: www.kobold.com

2. Note

Please read these operating instructions before unpacking and putting the unit into operation. Follow the instructions precisely as described herein.

The instruction manuals on our website www.kobold.com are always for currently manufactured version of our products. Due to technical changes, the instruction manuals available online may not always correspond to the product version you have purchased. If you need an instruction manual that corresponds to the purchased product version, you can request it from us free of charge by email (info.de@kobold.com) in PDF format, specifying the relevant invoice number and serial number. If you wish, the operating instructions can also be sent to you by post in paper form against an applicable postage fee.

The devices are only to be used, maintained and serviced by persons familiar with these operating instructions and in accordance with local regulations applying to Health & Safety and prevention of accidents.

When used in machines, the measuring unit should be used only when the machines fulfil the EC-machine guidelines.

as per PED 2014/68/EU

In acc. with Article 4 Paragraph 3, "Sound Engineering Practice", of the PED 2014/68/EU no CE mark.

Diagram 9, Pipe, Group 2 no dangerous fluids

3. Instrument Inspection

All Instruments are inspected before shipping and sent out in perfect condition. Should damage to a device be visible, we recommend a thorough inspection of the delivery packaging. In case of damage, please inform your parcel service / forwarding agent immediately, since they are responsible for damages during transit.

Scope of delivery:

The standard delivery includes:

- Screw-Volumeter model: OMG (incl. pulse generator)
- measuring transducer (only with OMG-../45)

4. Regulation Use

Any use of the OMG which exceeds the manufacturers specifications, may invalidate its warranty. Therefore, any resulting damage is not the responsibility of the manufacturer. The user assumes all risk for such usage.

5. Operating Principle

The measuring principle of the KOBOLD screw-volumeter is positive displacement.

The fluid to be measured causes the measuring spindles **M** to rotate. With each rotation an exact volume is given. These rotations are being transmitted to the display **A** by the pole wheel **P** and pick up **I**. At the display the volume can be shown in any unit of measurement.

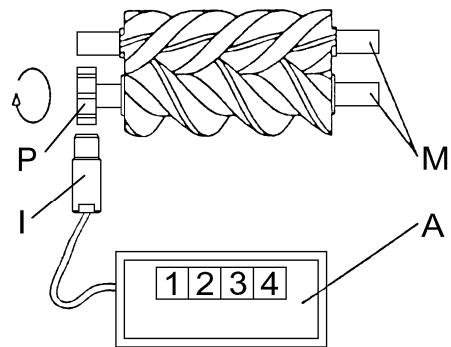

6. General Information

- It is important that any staff concerned with the unit read the operation and maintenance manual prior to start up of the unit.
- The user is responsible for taking all precautions outlined in this manual
- This screw-volumeter should not be operated outside of the data specifications given on the type plate. Any deviations require confirmation from the supplier.
- It is not possible to put all the information you may require in the manual. Should you require any special information, please contact us.
- Depending on the operating conditions, wear, corrosion or age of the unit, its specified attributes may be affected. It is therefore essential that the unit is periodically maintained. The user must replace all parts which would not guarantee a longer operating life with trouble-free operation. If the unit operates unusually or damage is observed, it is not allowed to continue operation.
- Installations which could lead to personal injury and/or material failure should be equipped with an alarm system and/or bypass. This system should be checked regularly.

7. Warranty

The warranty is according to our terms of delivery. Repairs during the guarantee period must be carried out only by individuals authorised by us and in accordance with our agreement and instructions.

8. Mechanical Connection

Mounting position: any
 Flow direction: flow direction: both directions are possible, preferable flow **D** according to the identification plate.

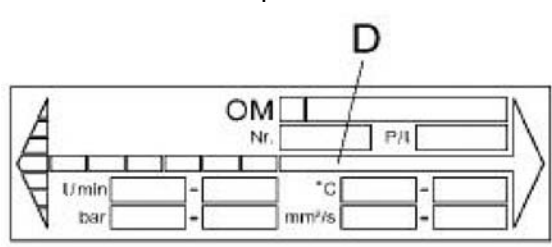

Minimum pressure: on the outlet of the volumeter the pressure should be higher than 0,1 bar. In no case the medium may run out free of the volumeter

Unclean medium: filtration with max. 0,3 - 0,5 mm mesh width is required

Foreign substance: the pipe system must be free from welding beads, scabs a. s.o., as they can block the volumeter

Over pressure valve: a blocked volumeter stops the complete flow of the medium, therefor depending the application, an overpressure valve is required.

Fastening: without tensions to prevent distortion of the volumeter pipe thread connection.

Pipe thread connection: the thread length of the pipe may not be longer than the thread length of the volumeter (reduction of the flow area resp. damage of internal parts of flowmeter)

Manometer connections: should be approachable
 thread: R 1/4")

Storing: incorrect storing can cause corrosion even seizing



Attention: When the volumeter or installations are damaged, medium could flow out. To prevent consequential damage an appropriate alarm device should be installed.

9. Electrical Connection

The dry sleeve is mounted, adjusted and tested with the pick up inside as a whole unit, by KOBOLD.

The pick-up insert, including milled nut and spring, are screwed into the dry sleeve by the customer (see included data sheet).



Caution: The dry sleeve must be free of foreign substance. The spring must be able to press the pick-up insert flush with the frontside of the dry sleeve.

The free cable ends will be connected to a display unit according connection diagram and technical data on the included data sheet.



Caution: The complete sensor unit (sensor, measuring transducer and cable) should not be located in an area of high intensity electromagnetic field, as may come from high voltage transmissions, electric motors, frequency converters etc,; this could cause measuring errors or even destruction of the sensor system.

Even though the pipe-system is filled the pick-up insert of the pick-up can be changed without regulating a new distance to the pole wheel.

Exchange pick-up insert E by opening milled nut R.

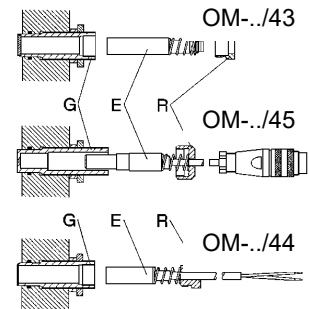

Caution: Dry sleeve G must not turn!

OM-.../44

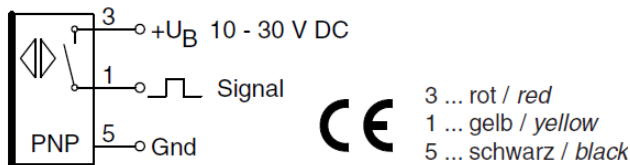

OM-.../45

OM-.../43

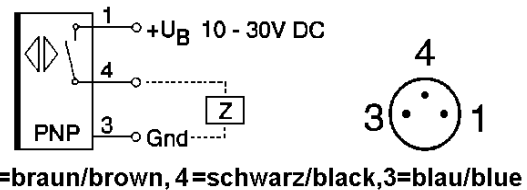
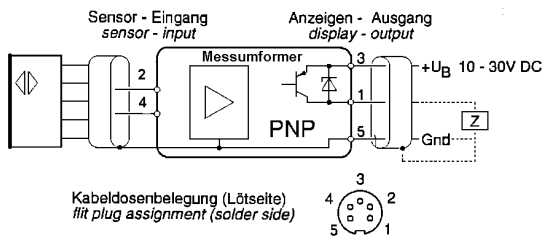

Further details about the pulse generators can be found in the additional instructions: "Operating instructions for pulse generators for the OM series... Type: /43../44../45"

10. Start up

Technical data on the identification plate and on the attached leaflets must be taken into consideration.

Venting: The system must be free of air (affects the accuracy)

11. Dismounting and Mounting

OMG 15

This work should be done by competent personnel only. This instruction should be used as a support for this activity. If spindle set, measuring casing or bearing will be replaced, volumeter must be recalibrated!

Dismounting:

- do not turn sensor sleeve
- if the red sealing point is damaged, the warranty for the flowmeter expires
- Remove volumeter from installation
- Remove flange cover (Fig.1)
- Remove bearing cover (Fig.2)
- Press out spindle set (with rolling bearings, distance sleeve and spacers) from measuring casing (Fig.3)
- change of bearings:
 - Remove pressed-on pole wheel from measuring spindle with detaching device.
 - Remove circlips and spacers
 - Remove rolling bearings
- Remove o-rings
- Clean all parts carefully, do not scratch sealing surfaces!

Mounting

- mount o-rings
- change of bearings:
 - press rolling bearings on measuring spindle
- press on pole wheel
- insert measuring spindle set into measuring case (Fig.3)
- press distance sleeve into measuring case
- mount spacers (Fig.3)
- mount bearing cover (Fig.2)
- mount flange cover (Fig.1)
- tighten screws crosswise
- install volumeter (see electrical connection)

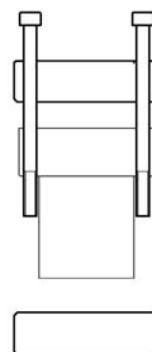

Fig.1

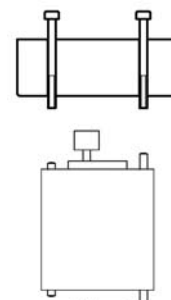

Fig.2

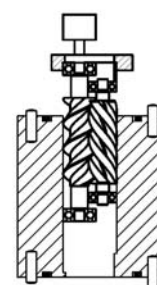

Fig.3

OMG - 20 / 25

This work should be done by competent personnel only. This instruction should be used as support for this activity. If spindle set or measuring casing will be replaced, volumeter must be recalibrated!

Dismounting:

- do not turn sensor sleeve
- if the red sealing point is damaged, the warranty for the flowmeter expires
- remove volumeter from installation
- remove end covers. If construction is with flange cover remove it also (Fig.1)
- press out spindle set (with rolling bearings and distance sleeve) from measuring casing (Fig.2)
- change of bearings:
 Large spindle: loosen the screw, remove wedge-locking plate and support-device and remove pressed-on pole wheel from measuring spindle with detaching device
 Small spindle: Remove screw, wedge locking plate and support device.
 remove rolling bearings
- remove o-rings
- Clean all parts carefully, do not scratch sealing surfaces!

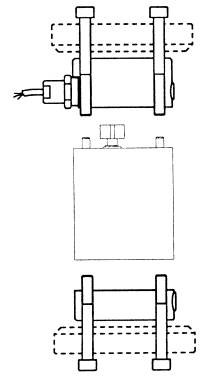

Fig.1

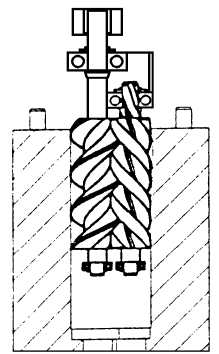

Fig.2

Mounting:

- mount o-rings
- change of bearings:
 press rolling bearings onto the measuring spindle
- mount the distance sleeve, the pole wheel, the support device and the wedge locking plate with the screw.
- turning moments for the screw:
 OMG20: Large spindle 2,9 Nm
 Small spindle 1,5 Nm
 OMG25: Large spindle 10,0 Nm
 Small spindle 6,0 Nm
- mount circlips and spacers (Fig.1)
- press on pole wheel
- insert spindle set into measuring case (Fig.2)
- press distance sleeve into measuring case
- mount end covers. If the construction is with flange cover, mount these too (Fig.3)
- tighten screws crosswise
- install volumeter

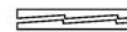

Fig.1

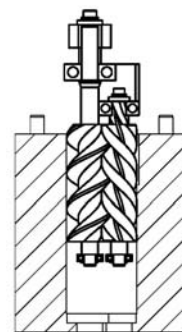

Fig.2

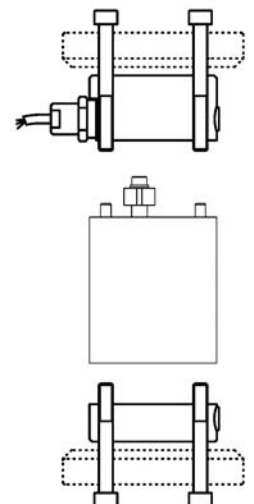

Fig.3

OMG - 40 / 50

This work should be done by competent personnel only. This instruction is only used as support for this activity. If spindle set or measuring casing will be replaced, volumeter must be recalibrated!

Dismounting:

- do not turn sensor sleeve
- if the red sealing point is damaged, the warranty for the flowmeter expires.
- remove volumeter from installation
- remove end covers (Fig.1).
- remove crown (without pick up) (Fig.2)
- loosen measuring casing and take it off carefully (Fig.3)
- Large spindle: loosen screw, remove wedge locking plate and support device, remove pressed on pole wheel with detaching device, remove distance-ring. (Fig.4a)
- remove circlips from crown
- remove spindle set (with rolling bearings) from crown (Fig.4)
- change of bearings:
Small spindle: Loosen screw, remove wedge locking plate and support device.
remove circlips and spacers (4b)
pull off rolling bearings
- remove o-rings
- Clean all parts carefully, do not scratch sealing surfaces!

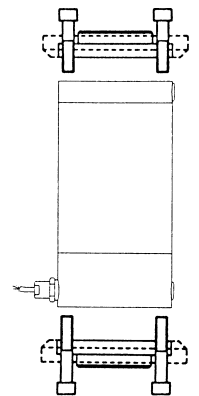

Fig.1

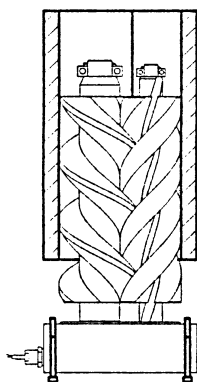

Fig.3

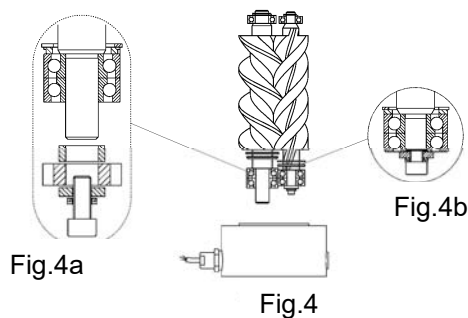

Fig.4a

Fig.4

Fig.4b

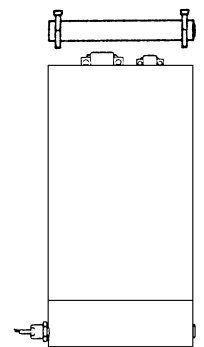

Fig.2

Mounting:

This work should be done by competent personnel only. This instruction should be used as support for this activity. If spindle set or measuring casing will be replaced, volumeter must be recalibrated!

- mount o-rings
- change of bearings:
- mount circlips and spacers (for boring) on pole wheel side.
- Pay attention to correct position of spacer! (Fig.2)
- turning moment for the screw:
 - OMG 40: large spindle 25 Nm
 - small spindle 10 Nm
 - OMG 50: large spindle 49 Nm
 - small spindle 25 Nm
- press on rolling bearings
- Caution: mount angular ball bearing in Y-arrangement
- mount circlips and spacers on measuring spindles
- mount spindle set into crown (with pick up) (Fig.3)
- mount circlips on crown
- push up pole wheel and tighten set screw on end face (Fig.4)
- mount measuring casing (Fig.3)
- mount crown (without pick up) (Fig. 5)
- mount flange covers (Fig. 6)
- tighten screws crosswise
- install volumeter

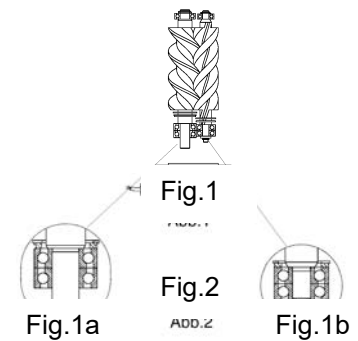

Fig.3

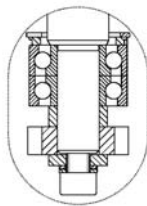

Fig.4

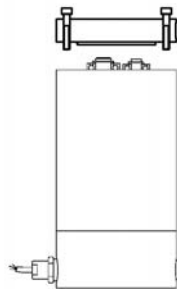

Fig.5

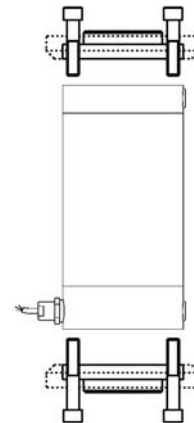

Fig.6

OMG-1H/1F

This work should be done by competent personnel only. This instruction should be used as support for this activity. If spindle set or measuring casing will be replaced, volumeter must be recalibrated!

Dismounting:

- do not turn sensor sleeve
- if the red sealing point is damaged, the warranty for the flowmeter expires.
- remove volumeter from installation
- remove end covers (Fig.1).
- remove crown (without pick up) (Fig.2)
- loosen measuring casing and take it off carefully (Fig. 3)
- Large spindle: Loosen the screw. Remove the wedge locking plate, the support device, the pole wheel with the help of a detaching device and the distance ring. (Fig. 4a)
- remove circlips from crown
- remove spindle set (with rolling bearings) from crown (Abb.4)
- small spindle: loosen the screw. Remove the wedge locking plate and the support device
- change of bearings:
 - remove second groove nut with locking plate
 - remove circlips and spacers
 - pull off rolling bearings
- remove o-rings
- Clean all parts carefully, do not scratch sealing surfaces!

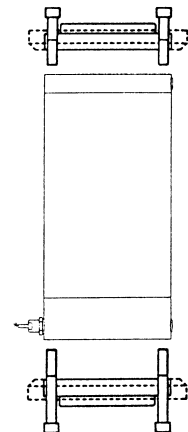

Fig.1

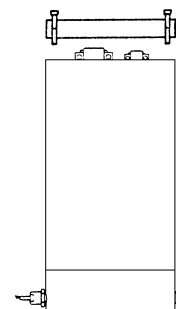

Fig.2

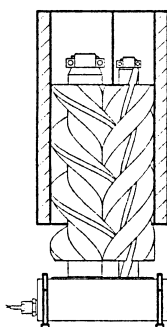

Fig.3

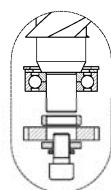

Fig.4a

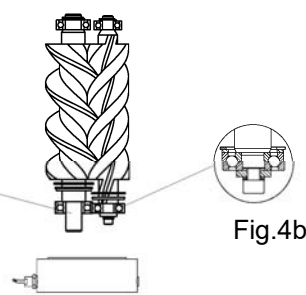

Fig.4

Fig.4b

Mounting:

This work should be done by competent personnel only. This instruction should be used as support for this activity. If spindle set or measuring casing will be replaced, volumeter must be recalibrated!

- mount o-rings
- change of bearings:
- mount circlips and spacers (for boring) on pole wheel side.
- press on rolling bearings
- turning moments for the screws:
 OMG-1H: large spindle 200 Nm
 small spindle 49 Nm
 OMG-1F: large spindle 200 Nm
 small spindle 86 Nm
- mount circlips and spacers on measuring spindles
- mount groove nut with locking plate on small measuring spindle (Fig.2)
- mount spindle set into crown (with pick up) (Fig.1)
- mount circlips on crown
- mount pole wheel with spacer, feather, locking plate and groove nut (Fig. 4)
- mount measuring casing (Fig.3)
- mount crown (with pick up) (Fig.5)
- mount flange covers (Fig. 6)
- tighten screws crosswise
- install volumeter

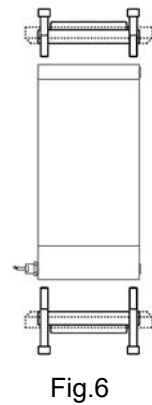
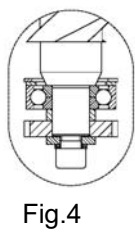
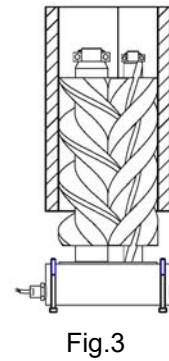
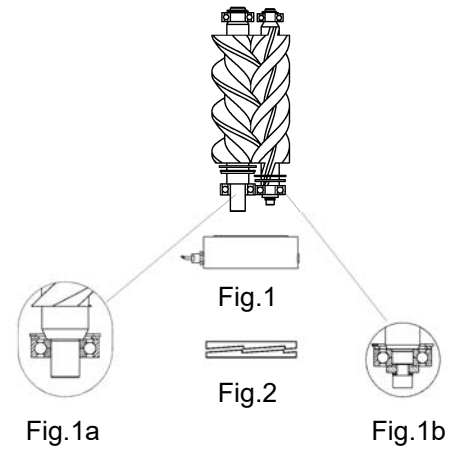

Dry sleeve

Dismounting:

- Empty screw volometer
- Open counter nut (hexagon 24)
- Unscrew the dry sleeve (hexagon 15)

Mounting:

- Screw in the dry sleeve until O-ring is sealed.
- Fill volometer with medium and start it.
- Screw in the dry sleeve carefully until it slightly grazes the rotating pole wheel (you can hear it through soft strikes), then turn back and tighten screw.
- Screw in pick up insert into dry sleeve.
- Proof signal with oscilloscope.
- If necessary correct distance.

12. Failure

Failure	Reason	Remedy
too high pressure drop	<ul style="list-style-type: none"> • Viscosity of medium and/or flow rate too high 	<ul style="list-style-type: none"> • raise temperature (consider allowed temperature range) • reduce flow rate • use bigger volumeter
leakage	<ul style="list-style-type: none"> • seal not tightened enough • seal is damaged 	<ul style="list-style-type: none"> • tighten screws • exchange seal • check chem. resistance
Blocked volumeter	<ul style="list-style-type: none"> • foreign substance • pick up mounted too far inside • medium is not lubricating enough • not enough inlet pressure 	<ul style="list-style-type: none"> • clean volumeter • use filtration (see chap. 8) • adjust pick up • use OMK • raise inlet pressure
too high measuring default	<ul style="list-style-type: none"> • air lock • degassing • too high pulsation • not enough counter pressure • operation <ul style="list-style-type: none"> -high flow fluctuation -quantity too small -different operation data • high wear • fault at the pick up and/or electronic 	<ul style="list-style-type: none"> • remove air • raise system pressure, reduce temp. • change pump, modify system • see min. pressure • change of operating conditions • new volumeter • filtration of abrasive material • see instructions of pick up and/or electronic
no signal	<ul style="list-style-type: none"> • defective pick up insert • defective connection • screw volumeter is not working • wrong power supply 	<ul style="list-style-type: none"> • screw out pick up insert and check it: pick up insert has to send a pulse by approximation to a ferromagnetic material (see luminous diode) • check luminous diode • check connections • put screw volumeter into action • adjust electronics
no ordinary signal	<ul style="list-style-type: none"> • defective pick up insert • defective contacts • external interferences • distance to pole wheel not correct 	<ul style="list-style-type: none"> • new pick up insert • check contacts • install cables (and measuring transducer) carefully • check signal with oscilloscope - correct the distance

13. Maintenance

KOBOLD-volumeters are free of maintenance. At high bearing load it is useful to change the rolling bearings after a certain service life.

When high accuracy is required, it is further advisable to calibrate the device periodically.

14. Technical Information

Housing:	ductile iron EN GJS-400
Spindles:	steel nitrated
O-rings:	FKM or EPDM
Bearings:	steel or hybrid ball bearing
Thread for sensors:	M 18 x 1 with O-ring in the case
Viscosity range:	1-5000 mm ² /s
Flange:	steel (material no. 1.7139), sealing face form C, according to DIN 2526
Pole Wheel:	steel
Operating temperature:	-20 to +200 °C (Please note limitation due to pulse generator.)
Application:	lubricating liquids

Accuracy Diagram

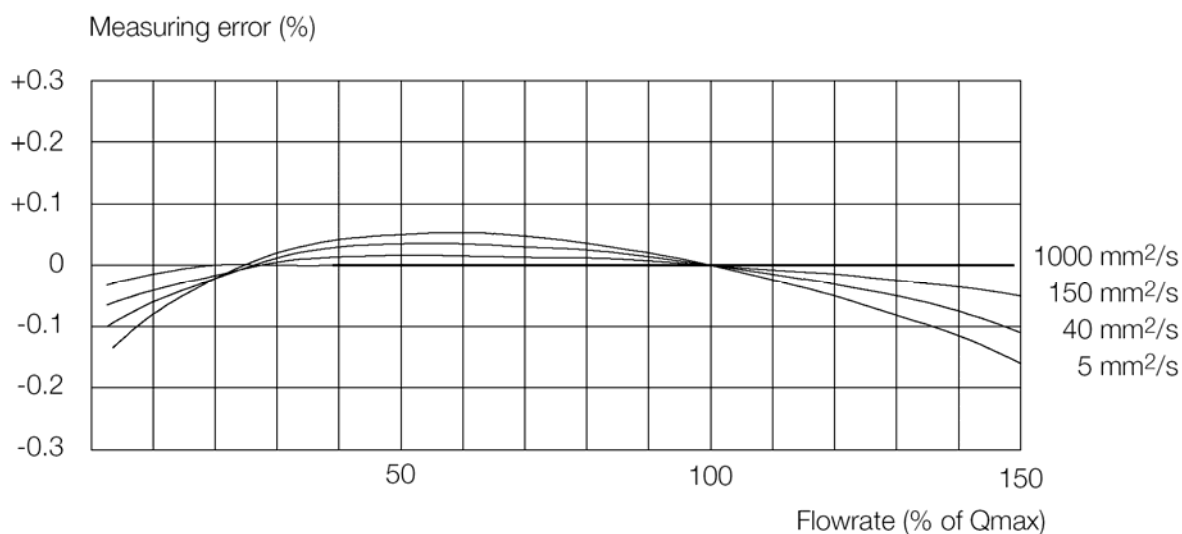

The measuring error refers to the actual flow rate. The diagram shows the characteristic for the OMG-...screw-type volumetric flowmeter. A test certificate is available because every device delivered is different.

OM.../43

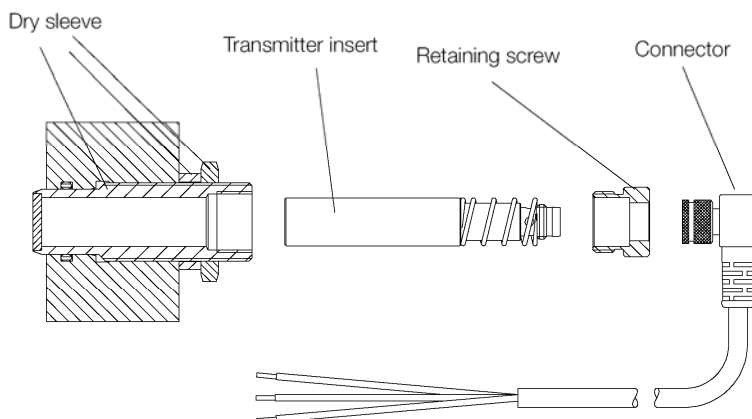

OM.../44

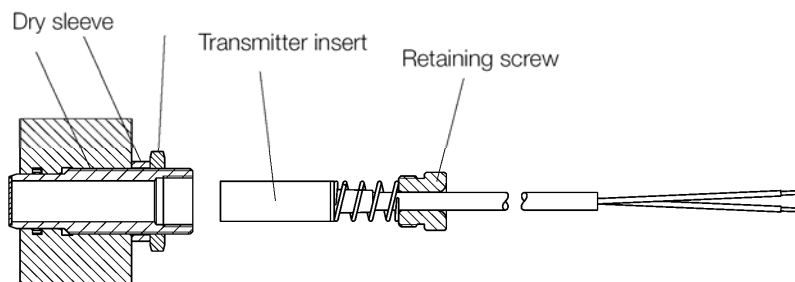

OM.../45

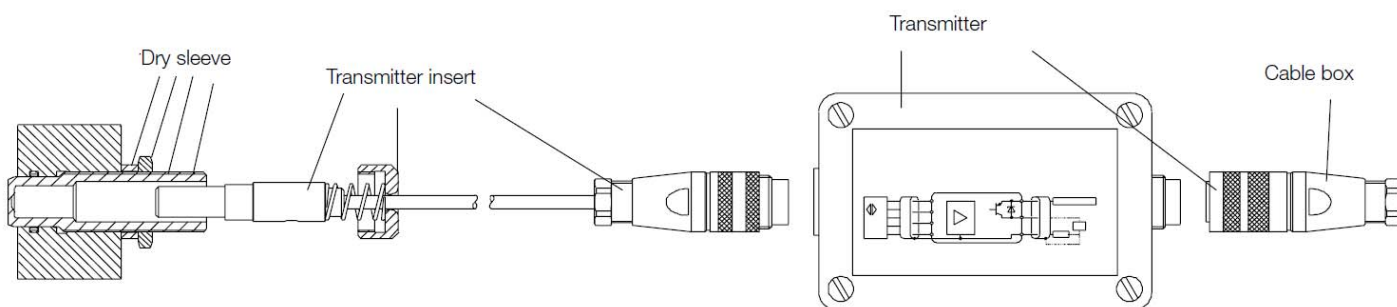

Technical Details Pulse Generators

Model	System	Voltage	t_{max}	p_{max} face	Material dry sleeve	Electrical connection	Protectio n
43	inductive PNP	10...30 V _{DC}	-20..+100°C (-25..+90°C) ¹⁾	250 bar	arcap/ ceramics	right-angle plug with LED and 3 m cable	IP 65
44	Hall-effect PNP	10...30 V _{DC}	-40..+150°C	420 bar	arcap	3 m PTFE cable	IP 67
45	magnetic PNP	10...30 V _{DC}	-40..+250°C (0..+50°C) ²⁾	420 bar	arcap	incl. transmitter/ cable box with 1 m PTFE cable	IP 65

¹⁾ Connector
²⁾ Transmitter

15. Order Codes

Example: **OMG-15F15401H4**

Flow rate [l/min]	Code	Process connection	P _{max} ¹⁾ [bar]	Pulses/L ²⁾	Frequency ²⁾ [Hz]	Gasket	Bearings	Pulse generator ³⁾
0.1 - 10	OMG-15	R1500 = G½ F1540 = DN15/PN40 F151S = DN15/PN160 F152F = DN15/PN250	250	1216	2.0-203	1 = FKM 2 = EPDM	S = steel ball bearing	3 = model 43 4 = model 44 5 = model 45
0.3 - 30	OMG-20	R2000 = G¾ F2040 = DN20/PN40 F151S = DN15/PN160 F152F = DN15/PN250	250	640	3.2-320			
1 - 100	OMG-25	R2500 = G1 F3240 = DN32/PN40 F251S = DN25/PN160 F252F = DN25/PN250	250	234	3.9-390		H = hybrid ball bearing	
3.5 - 350	OMG-40	R4000 = G1½ F4040 = DN40/PN40 F401S = DN40/PN160	160	71	4.1-414			
7 - 700	OMG-50	R5000 = G2 F5040 = DN50/PN40 F501H = DN50/PN100	100	39.8	4.6-464			
20 - 2000	OMG-1H	R1H00 = G4 F1H16 = DN100/PN16 F1H40 = DN100/PN40	40	16.8	4.6-560	1 = FKM	S = steel ball bearing	
50-5000	OMG-1F	R1F00 = G6 F1F16 = DN150/PN16 F1F40 = DN150/PN40	40	8.85	7.4-738			

¹⁾ Please note limitations due to pulse generator and flange pressure rating.

²⁾ Pulse generator 45 has higher pulse/L und output frequency (for values see type plate and on request)

³⁾ Specifications see table „Technical Details Pulse Generators“.

16. Dimensions and weights

OMG threaded connection

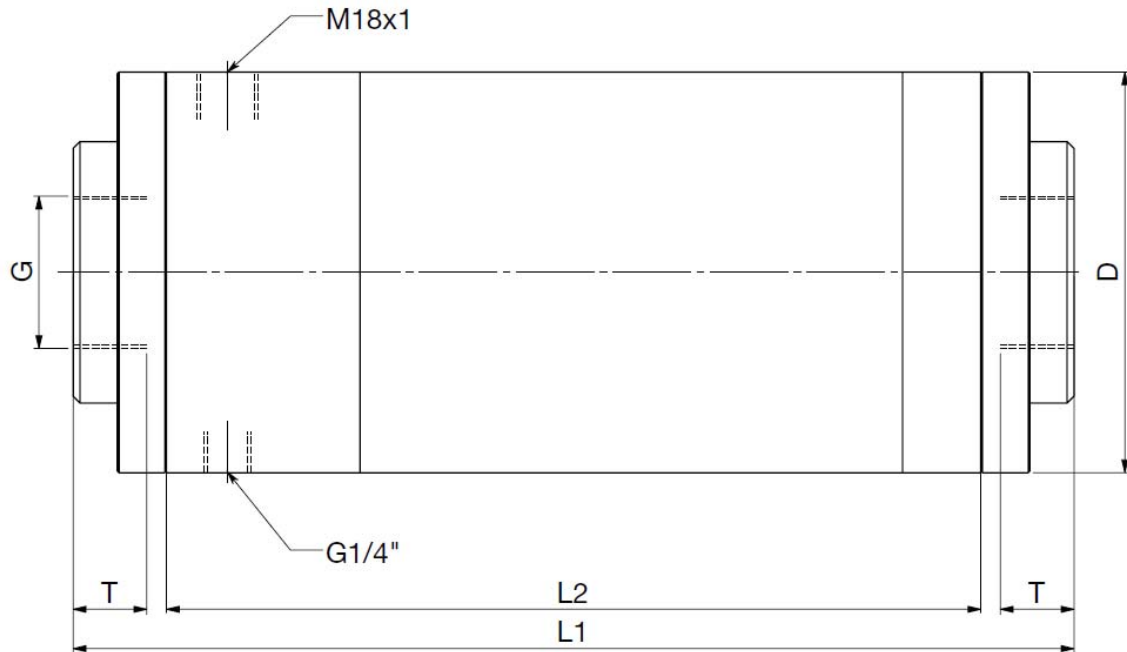

Model	Connection	Pressure rating [bar]	D [mm]	L1 [mm]	L2 [mm]	T [mm]	Weight [kg]
OMG 15R15...	G $\frac{1}{2}$	250	90	145	94	16	4.6
OMG 20R20...	G $\frac{3}{4}$	250	74	145	145	16	4.1
OMG 25R25...	G1	250	104	215	215	18	11
OMG-40R40...	G $\frac{1}{2}$	160	118	295	240	27.5	18
OMG-50R50...	G2	100	138	355	295	30	29
OMG-1HR1H...	G4	40	188	480	400	40	70
OMG-1FR1F...	G6	40	267	645	537	54	180

OMG Flange version

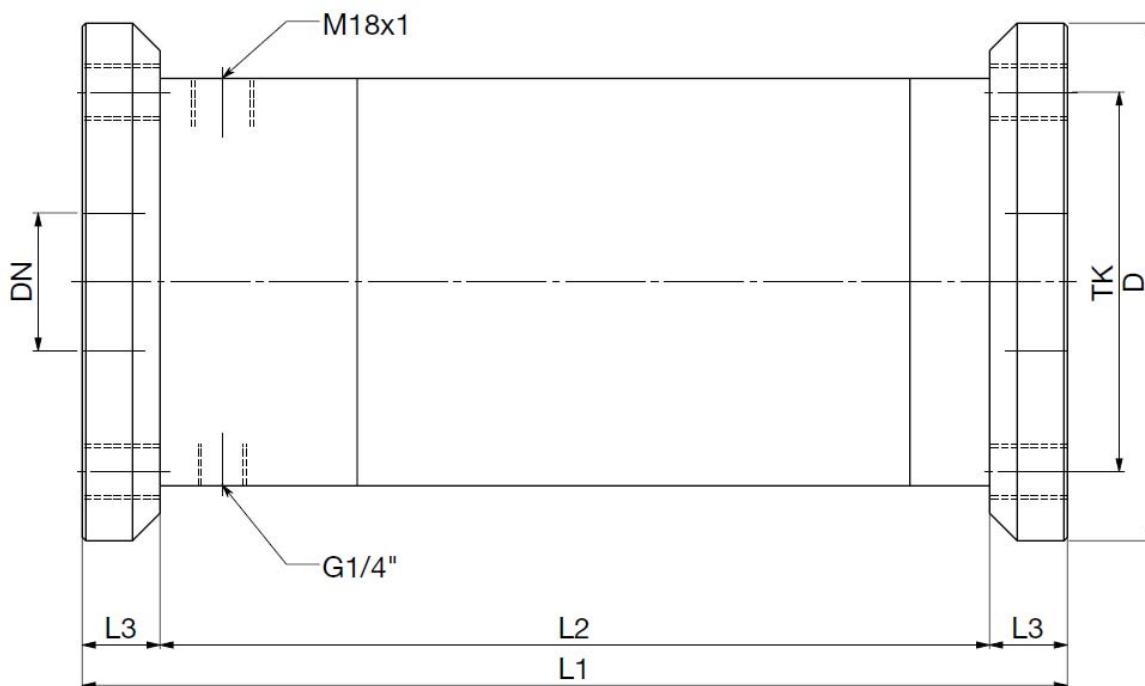

Model	Connection	Pressure rating [bar]	D [mm]	L1 [mm]	L2 [mm]	L3 [mm]	TK [mm]	Weight [kg]
OMG-15F1540...	DN15	PN40	95	145	94	25.5*	65	4.7
OMG-15F151S...	DN15	PN160	105	145	94	25.5*	75	4.8
OMG-15F152F...	DN15	PN250	130	145	94	25.5	90	6
OMG-20F2040...	DN20	PN40	105	185	145	20	75	6
OMG-20F151S...	DN15	PN160	105	185	145	20	75	6
OMG-20F152F...	DN15	PN250	130	195	145	25	90	8.1
OMG-25F3240...	DN32	PN40	140	365	215	25	100	16
OMG-25F251S...	DN25	PN160	140	265	215	25	100	16
OMG-25F252F...	DN25	PN250	150	275	215	30	105	19
OMG-40F4040...	DN40	PN40	150	285	240	22.5	110	21
OMG-40F401S...	DN40	PN160	170	295	240	27.5	125	23
OMG-50F5040...	DN50	PN40	165	340	295	22.5	125	31
OMG-50F501H...	DN50	PN100	195	355	295	30	145	37
OMG-1HF1H16...	DN100	PN16	220	450	400	25	180	65
OMG-1HF1H40...	DN100	PN40	235	460	400	30	190	70
OMG-1FF1F16...	DN150	PN16	285	600	537	31.5	240	170
OMG-1FF1F40...	DN150	PN40	300	610	537	36.5	250	180

17. Pressure loss diagram

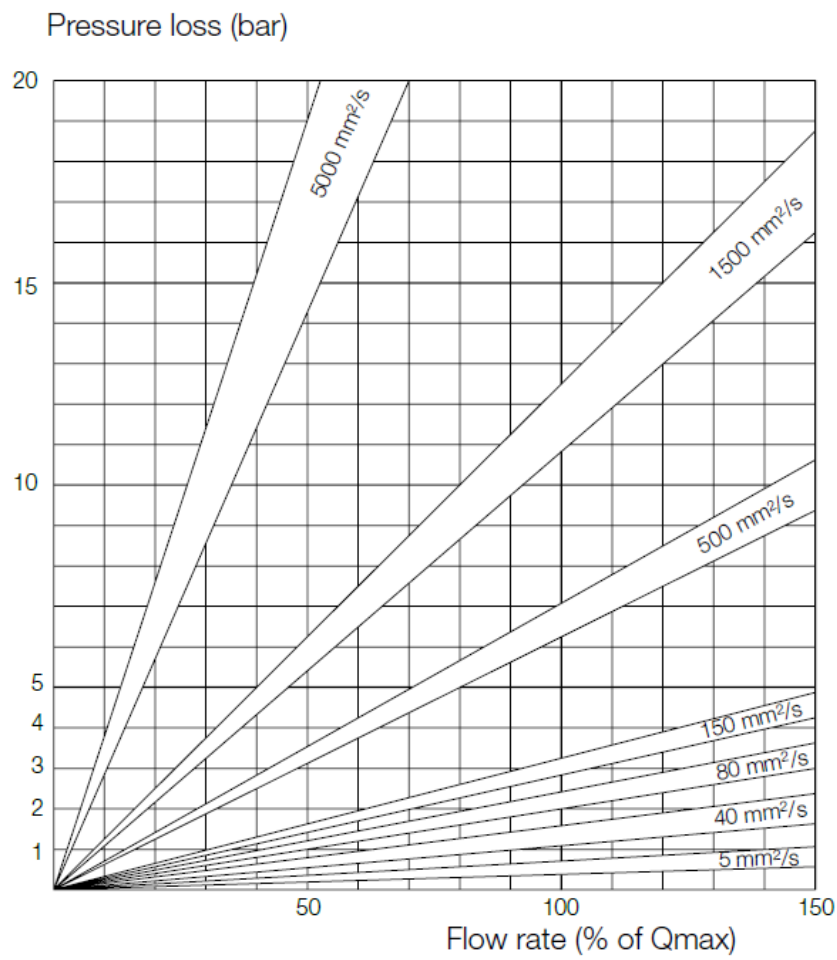

18. Disposal

Note!

- Avoid environmental damage caused by media-contaminated parts
- Dispose of the device and packaging in an environmentally friendly manner
- Comply with applicable national and international disposal regulations and environmental regulations.

Batteries

Batteries containing pollutants are marked with a sign consisting of a crossed-out garbage can and the chemical symbol (Cd, Hg, Li or Pb) of the heavy metal that is decisive for the classification as containing pollutants:

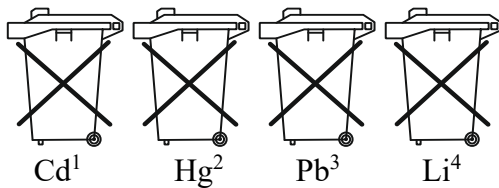

1. „Cd" stands for cadmium
2. „Hg" stands for mercury
3. „Pb" stands for lead
4. „Li" stands for lithium

Electrical and electronic equipment

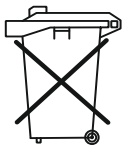

19. Manufacturer's declaration

We, Kobold Messring GmbH, Hofheim-Ts., Federal Republic of Germany, hereby declare that the

type OMG screw volumeters

are intended to be fitted into a machine or assembled with other machinery to form a machine in accordance with Directive 2006/42/EC including its amendments, and that

- the following harmonised standards (or parts/clauses thereof) have been applied:
 - EN 292 Safety of machinery - Basic concepts, general principles of design
 - EN 983 Safety of machinery - Safety requirements for fluid power systems
 - EN 1050 Safety of machinery - Principles for risk assessment
- the risk analyses have been carried out
- the technical design documents have been set up
- the design of the machine complies with the provisions of the machinery directive
- the following national or international technical standards (or parts/clauses thereof) and specifications have been applied:
 - DIN 17100, 17200, 17210 - Ferrous materials
 - DIN, SAE, ANSI, JIS - Flange connection dimensions
 - ISO 228-1, NPT - Threaded connection dimensions
 - DIN 55350 - Quality test certificate
- due to the manufacturer's scope of delivery, it was not possible to take the following functions into account:
control system; operating system; power supply system

For this reason, the party putting the machine into operation must carry out the risk analysis for the missing functions before doing so and provide the machine with the CE marking if necessary.

Furthermore we declare that the machine must not be put into operation until the machinery into which it is incorporated or of which it is a component conforms as a whole (i.e. including the machine for which this has been issued) with the provisions of Directive 98/37/EC and the respective national legislation for implementing the Directive in national law, and the corresponding declaration of conformity has been issued.



H. Peters
General Manager



M. Wenzel
Proxy Holder

Hofheim, 15. Jan. 2016

20. EU Declaration of conformance

We, KOBOLD Messring GmbH, Hofheim-Ts, Germany, declare under our sole responsibility that the product:

Screw volumeter Model: OMG-...

to which this declaration relates is in conformity with the standards noted below:

EN IEC 63000:2018 Technical documentation for the assessment of electrical and electronic products with respect to the restriction of hazardous substances

Also, the following EC guidelines are fulfilled:

2011/65/EU RoHS (category 9)
2015/863/EU Delegated Directive (RoHS III)

Additional for pulse generator **OM.../43:**

The product is in conformity with the standards noted below:

EN 55011:2016+A1:2017, EN 55011:2016/A11:2020 (Gruppe 1, Klasse B)
Industrial, scientific and medical equipment - Radio-frequency disturbance characteristics - Limits and methods of measurement

EN 60947-5-2:2007+A1:2012, Abs. 8.6 Low-voltage switchgear and controlgear - Part 5-2: Control circuit devices and switching elements - Proximity switches

Also, the following EC guidelines are fulfilled:

2014/30/EU EMC Directive

Additional for pulse generator **OM.../44:**

The product is in conformity with the standards noted below:

EN 61326-1:2013 Electrical equipment for measurement, control and laboratory use - EMC requirements - Part 1: General requirements

Also, the following EC guidelines are fulfilled:

2014/30/EU EMC Directive

Additional for pulse generator **OM.../45:**

The product is in conformity with the standards noted below:

EN 61000-6-2:2005/AC:2005 Electromagnetic compatibility (EMC) - Part 6-2: Generic standards - Immunity for industrial environments

EN 61000-6-4:2007/A1:2011 Electromagnetic compatibility (EMC) - Part 6-4: Generic standards - Emission standard for industrial environments

Also, the following EC guidelines are fulfilled:

2014/30/EU **EMC Directive**

Hofheim, 09 Nov. 2022



H. Volz
General Manager



M. Wenzel
Proxy Holder