

Instruction Manual

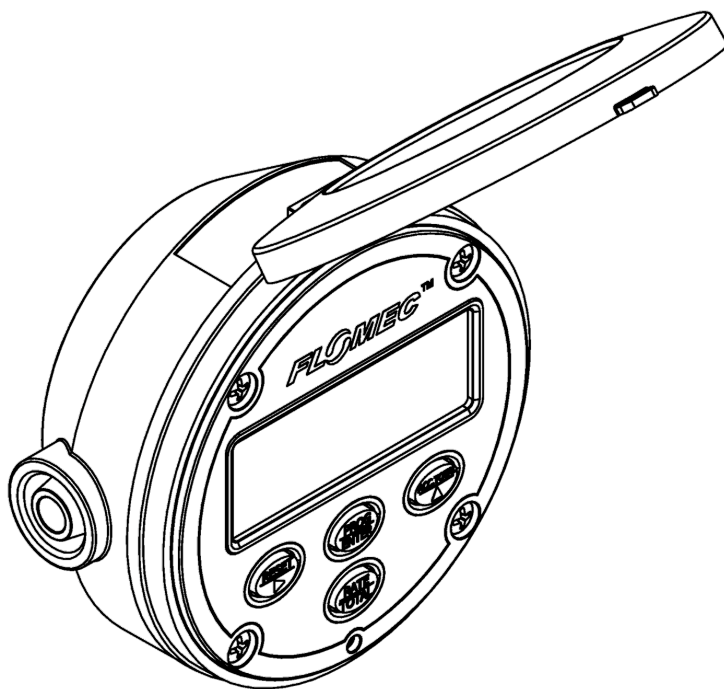

General Information

This manual provides the necessary information for installation and operation of your flow instrument; for detailed information on any flowmeters or accessories supplied with your instrument please consult the relevant flowmeter product manual. This instrument should only be installed and maintained by persons familiar with local regulations, particularly those for workplace Health and Safety.

For best results, please make yourself familiar with the contents of all relevant product manuals prior to installation and commissioning. If further assistance is required please consult the distributor from whom you purchased your device.



CAUTION

For intrinsically safe installations the instructions in section 5 of this manual must be followed to ensure explosion safety

DISPOSAL WITHIN THE EUROPEAN UNION - WEEE



- The WEEE Directive requires that this product be recycled when disposed of within the European Union
- The crossed out wheeled bin symbol shown in this manual signifies that this product should not be disposed of in general waste or landfill.
- Please contact the local dealer or national distributor from whom this product was purchased for information on recycling electronic equipment within your region.

Table of Contents

1.	Introduction	4
1.1	Product Overview.....	4
1.2	Specifications.....	5
2.	Operation	6
2.1	LCD Display.....	6
2.2	Keypad Function.....	7
2.3	Operating Functions.....	8
3.	Mechanical Installation	13
3.1	General Requirements.....	13
3.2	Conduit Entries.....	13
3.3	Integral Meter Mounting.....	13
3.4	Wall and Pipe Mounting.....	13
3.5	Panel Mounting.....	14
4.	Electrical Installation	15
4.1	Terminal Identification.....	15
4.2	Input Connections.....	16
4.3	Output Connections.....	18
4.4	Connections for Combined Outputs.....	23
5.	Intrinsically Safe Installations	24
5.1	General Information.....	24
5.2	Label Information.....	24
5.3	Conforming Standards.....	25
5.4	Intrinsically Safe Electrical Installation.....	25
5.5	Intrinsically Safe Battery Replacement.....	28
5.6	Service and Repair.....	29
6.	Programming Parameters	30
6.1	PIN Program Protection.....	30
6.2	Engineering Units.....	30
6.3	Time-base for Rate.....	30
6.4	Decimal Places.....	31
6.5	K-Factor Entry.....	31
6.6	Input Type Configuration.....	31
6.7	Non-Linearity Correction.....	31
6.8	Digital Output.....	32
6.9	Analogue Output.....	33
6.10	Advanced Menu.....	34
7.	Programming Flowchart	36
8.	Program Detail Record	39
9.	Spare Parts	40
10.	EU Declaration of Conformity	41

1. Introduction

1.1 Product Overview

The RT14 Rate Totaliser is designed for computing, displaying and transmitting totals and flowrates from a flowmeter with a pulse or frequency output. The instrument will display Flow Rate, Total and Accumulated Total in engineering units as programmed by the user. Simple flow chart programming with scrolling English prompts guides you through the programming routine greatly reducing the need to refer to the instruction manual. All user program data is retained if the battery is removed.

Environments

The instrument is weatherproof to IP66/67 (Nema 4X) standards; a UV resistant glass reinforced nylon housing with stainless steel screws & a mix of Nitrile O-ring seals and Polyurethane gaskets allow the instrument to maintain its environmental protection across a wide operating temperature range. The instrument suits harsh indoor and outdoor environments & conforms to the European Directive for Electro Magnetic Compatibility. This product is available in ***Safe Area Only*** and ***Intrinsically Safe*** versions suitable for use in hazardous areas – ***Safe Area Only models must never be installed in a hazardous area.***

Features

Displays of Total, Accumulated Total, and Flowrate, 10 point Linearisation, PIN Protection, 4~20mA analogue output, selectable digital output for pulse output or High / Low flow alarms.

Installation

Specifically engineered to be directly mounted on a variety of flowmeters, wall or surface mounted, pipe or panel mounted. Various mounting kits are available. The instrument can be self-powered or may be powered by an external DC supply or by a 2-wire analogue loop.

1.2 Specifications

Physical	High impact glass reinforced Nylon (PA6) with a Polycarbonate lens, Nitrile O-Ring seals and Polyurethane gaskets, providing an IP rating of IP66/67 Operating Temperature Range is -30°C ~ +80°C (-22°F ~ +176°F) -30°C ~ +70°C (-22°F ~ +158°F) for intrinsic safety
LCD Display:	8 digit alpha-numeric LCD display with 12mm characters Display backlight available with external DC power
Units	Total units are selectable for litres, millilitres, gallons, cubic metres, quarts, kilograms, pounds, or NONE. Rate units are independently selectable for all of the above, with time-base options of /second, /minute, /hour, or /day
Signal Input:	Universal pulse/frequency input compatible with Reed Switch, NPN or PNP sensors, Variable Reluctance Coils (Turbine Flowmeters), and Weigand Sensors (voltage pulse signals). 1.2Khz maximum input frequency for NPN/PNP, 2kHz maximum for Coil inputs, 120Hz maximum for Reed Switch inputs. Minimum signal amplitude for Coil signals is 90mV pk-pk
Sensor Power	5V/20mA regulated sensor supply is available with external DC power applied. A separate low power sensor supply is available when loop powered
Battery Power	AA 3.6V Lithium Thionyl Chloride Battery Expected battery life under ideal conditions is 5 years See section 2.3.11 for more details on battery life
External DC Power	Regulated 12V ~ 30V DC Maximum current draw on external power is 100mA @ 30V
Loop Power	12 ~ 30V DC 2-wire loop power Load Limits: @ 30VDC – 900Ω Max @24VDC – 630Ω Max @12VDC – 90Ω Max
Analogue Output	12 Bit 4-20mA analogue signal with an accuracy of ±0.05% F.S. at 25°C ±0.25% F.S. at extreme ambient temperatures (-30°C or +80°C) Software setting of Zero and Span, software trim of zero and full scale 22mA over-range when full-scale flowrate is exceeded
Digital Output	One selectable digital output programmable for Scaled Pulse, Unscaled Pulse, High Alarm, Low Alarm, or High/Low Alarm. 100Hz Maximum output frequency for scaled pulse or alarms.
Passive NPN Out	Passive NPN digital output, 30VDC 300mA max. (100mA max for intrinsic safety) Can be operated on battery power with a reduced battery lifetime See section 2.3.11
Isolated Digital Out	Isolated digital output which is NPN/PNP selectable via wiring. 50V AC/DC 300mA max. (24VDC / 200mA max. for intrinsic safety) *requires external DC power to operate*

2. Operation

2.1 LCD Display



Upon entering the programming mode the LCD will conduct a display test where all LCD segments are displayed for 3 seconds



Rate display is indicated by the RATE flag in the bottom row of the display. 8 digits are available for Rate display, user selectable for up to 3 decimal places.

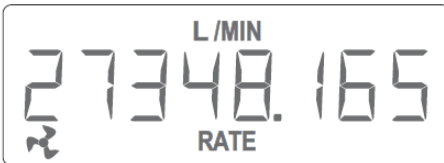

Rate units and time-base are displayed at the top of the display. Rate units may differ from Total units (e.g. Litres and mL/min)



Total display and Accumulated Total displays are also indicated clearly with identifiers shown in the bottom row of the display.

The presence of an input signal is indicated by movement of the flow indicator (propeller) in the bottom left of the display. At low input frequencies the flow indicator will move upon receipt of each individual input pulse, and at higher input frequencies it will rotate at a fixed speed.

The LCD display will update with a frequency of 1Hz when the instrument is operating on battery power; this will increase for a period of 30 seconds following a button press to 8Hz for totals and 4Hz for flowrate. When powered by external DC or Loop power the LCD will update at a constant 8Hz/4Hz.

2.2 Keypad Function

KEY	FUNCTION IN OPERATING MODE	FUNCTION IN PROGRAM MODE
	Press and hold for 3 seconds to reset the Total display to zero. Total must be displayed on LCD display to reset it	Selects the digit to be incremented/edited, moves the cursor to the right.
	Press and hold to display the software version (tag number is displayed if enabled)	Each press progresses to the next program step. Holding for 3 seconds will save all program settings and exit to operating mode.
	Press and hold to display the accumulated total. Holding this key for 10 seconds will latch the accumulated total display.	Increments the selected digit
	Toggles between the Rate and Total displays	Moves one step backwards in the program
	Press and hold both buttons simultaneously for a duration of 5 seconds to enter the programming mode	No Function
	Press and hold PROG/ENTER and then press RESET to toggle between displaying software version, serial number, and tag number (if tag no. is enabled)	No Function
	Press and hold for 7 seconds to perform a hard restart of the software. To be used in the case of 'frozen' software which may be caused by user faults such as short circuiting of the instrument.	*CAUTION* Press and hold for 7 seconds in Programming Mode to wipe all settings from the device and reset to factory default settings. Record all important settings before resetting the instrument.

2.3 Operating Functions

2.3.1 Resettable Total

The display toggles between Rate and Total displays when the RATE/TOTAL key is pressed. Pressing the RESET key and holding for a period of 3 seconds while the Total is displayed on the LCD will cause the Total to reset to zero.

2.3.2 Accumulated Total

The Accumulated Total is displayed momentarily whenever the ACC.TOTAL key is pressed, holding the key will hold the Accumulated Total display. If permanent display of the Accumulated Total is required, this can be achieved by pressing and holding the ACC.TOTAL key for a period of 10 seconds. Once this is done the Accumulated Total display will latch every time the ACC.TOTAL key is pressed; to revert the Accumulated Total display to a momentary display hold the ACC.TOTAL key again for 10 seconds.

The Accumulated Total display can only be reset by entering into the Programming Mode and progressing to the Accumulated Total Reset function in the Advanced Menu. Protection of the Accumulated Total reset can be achieved by PIN protecting the Programming Mode.

2.3.3 Rate Display

The Flow Rate Display is toggled by pressing the RATE/TOTAL key; Rate display remains active until the RATE/TOTAL key is pressed again. The update frequency of the Rate display is influenced by two parameters; the update frequency of the display (1Hz on battery power, 4Hz on external DC or loop power), and the Rate Calculation Pulses parameter. If the update frequency of the Rate Display is too slow consider reducing the number of pulses for the rate calculation (see section 5.10). Conversely if it is required to stabilise an erratic Rate Display, increasing the Rate Calculation Pulses parameter will achieve this.

Other parameters which influence the Rate Display are the Rate Damping, and Low Frequency Cut-Off settings. Rate Damping will smooth out rapid changes in the flow rate in order to maintain a steady display, however in systems where fast changes in the flowrate must be displayed the Rate Damping parameter should be minimised.

The minimum input frequency requirement for a Rate Display is 0.2Hz with the factory settings; this can be reduced to 0.1Hz by adjusting the Low Frequency Cut-off parameter. Note that Totalisation is not affected by the Low Frequency Cut-off parameter.

2.3.4 Display Backlight

The display backlight will be automatically enabled upon connection of an external DC voltage supply in the range of 12-30V; the backlight is not available when operating on battery or loop power. If it is required to reduce power consumption while operating on external DC power the backlight can be overridden in the Advanced Menu (see section 5.10).

2.3.5 Analogue Output

The loop powered 4-20mA Analogue Output is a passive non-isolated output capable of retransmitting the flowrate to remote instrumentation or control systems such as a PLC or DCS. The Analogue Output can be spanned anywhere within the operating range of the associated flowmeter; both the 4mA and 20mA points are software programmable in the units selected for the Rate display. The instrument will over-range to 22mA which allows the user to identify when the system is exceeding its maximum normal flowrate (*i.e. identifying a fault condition*).

The Analogue Output accuracy is $\pm 0.05\%$ of Full Scale (0.01mA) at a regular ambient temperature of 25°C. Due to the effects of temperature changes on the internal components, the accuracy will become progressively worse as the ambient temperature moves further away from 25°C; up to a worst case of $\pm 0.25\%$ of Full Scale (0.05mA) at the extremes of the instrument's operating range (-30°C or +80°C) ****note intrinsically safe installations are limited to +70°C (158°F)***

If required, the Analogue Output can be software adjusted to achieve the best accuracy under the specific operating temperature of your installation. The 4mA and 20mA points are both adjustable in 0.001mA increments by accessing the Analogue Output Adjustment section of the Advanced Menu (see section 5.10 of this manual).

2.3.6 Unscaled Pulse Output

The Unscaled Pulse Output function is used to retransmit the input signal from the associated flowmeter; it will maintain the same frequency and duty cycle as the input signal. When setting up a system with two separate Total displays on two separate instruments the Unscaled Pulse Output is the best method of transmitting the Total value to the secondary totalising instrument.

The Unscaled Pulse signal can be transmitted as an NPN signal from the passive digital output, or as an NPN or PNP signal from the isolated digital output. The passive digital output can be used on battery power, however transmitting the signal via the isolated output will require an external DC power supply.

2.3.7 Scaled Pulse Output

The Scaled Pulse Output is used to transmit the totalised volume at a user selectable resolution; this is programmed as a volume quantity per output pulse (e.g. 10Litres/Pulse or 100mL/Pulse). The frequency of the Scaled Pulse Output signal automatically adjusts according to the input frequency and the scale factor, up to a maximum limit of 100Hz.

The Scaled Pulse signal can be transmitted in the same way as the Unscaled Pulse signal above, either through the passive or isolated output.

The pulse width of the Scaled Pulse output is fixed at 300ms for output frequencies below 1.67Hz, however once above 1.67Hz the instrument adjusts the pulse width according to the frequency to give a 50:50 duty cycle up to the maximum output frequency of 100Hz. Systems should be designed to stay below the 100Hz limit, however if 100Hz is exceeded the instrument will output at 100Hz and store any excess pulses in memory. Pulses stored in memory will continue to output after the flow has stopped until the stored pulse count reaches zero.

2.3.8 Alarm Output

Flow Rate Alarms may be programmed for High, Low, or High/Low; the digital output will trigger when the registered flowrate passes the configured set-point(s). For a Low Alarm the output will trigger once the flowrate drops below the set-point, a High Alarm will trigger with a flowrate over the set-point, and a High/Low alarm will trigger if the flowrate is either over the upper set-point or below the lower-set point.

Each set-point is configured with its own dead-band percentage which allows the user to set a buffer zone (hysteresis) to avoid alarm “chattering” (switching quickly on-off-on-off) with a flowrate hovering around the set-point. The dead-band setting is entered as a percentage of the set-point value; e.g. a 5% dead-band with a 100L/min High Flow Alarm will trigger ON at 100L/min but will not turn OFF until the flow drops to below 95L/min.

Alarm Outputs can operate as an NPN signal via the passive digital output, or as a PNP or NPN signal via the opto-isolated output. For relay switching be sure to follow the requirements in the relevant wiring diagram in section 4.3.

2.3.9 Passive NPN Transistor Output

The passive NPN transistor output is the default method of transmitting the pulse or alarm outputs, as it is the easiest and lowest cost solution where an NPN signal below 30VDC is suitable. The passive NPN output shares a common ground inside the instrument, so may not be suitable for installations requiring an analogue output in combination with a digital output, as it may cause analogue signal issues due to the formation of a ground loop.

The passive NPN output will function on battery power, however this will reduce the battery life of the instrument by approximately 50%. For applications requiring an alarm output which is not triggered often the effect on battery life is expected to be negligible.

Internal protection is provided for voltage spikes caused by switching inductive loads (relays, solenoids, etc.) by fitment of an internal flyback (suppressor) diode to the passive NPN output. No additional circuit components are required when triggering a DC relay or DC solenoid with this output.

2.3.10 Isolated Digital Output

The Isolated digital output is provided by means of an Opto-Coupler, which provides a signal with no electrical connections to the other internal circuitry of the instrument. The isolated output should be used preferentially whenever a user requires both an analogue output and a digital output (alarm or pulse signal) to a common receiving instrument; this will avoid the creation of ground loops which interrupt the analogue signal. The isolated digital output is also chosen whenever a PNP signal is required; the configuration of PNP vs. NPN is accomplished via wiring which can be seen in the electrical installation section of this manual (*section 4.3*).

The isolated digital output is rated to 50V AC or DC, and 300mA; so should be used instead of the passive NPN output for switching any loads greater than 30VDC or for switching any low voltage AC loads <50VAC. ****For intrinsically Safe installations this output is limited to 24VDC / 200mA and is only useful when an output DC current between 100mA and 200mA is required.***

The isolated digital output is not internally protected from voltage spikes generated by inductive loads such as relays or solenoids, so a diode (*1N004 recommended*) should be fitted across any inductive DC loads as shown in section 4.3.5. For AC relays or solenoids voltage spike protection should be provided by fitment of a metal oxide varistor fitted in place of the diode (*EPCOS SIOV-S05K50 or SIOV-S07K50 recommended*). *Where the recommended diode or varistor is not available, a similar component of equivalent specification may be used.*

2.3.11 Battery Power

The instrument is powered by a Lithium Thionyl Chloride (Li/SOCl₂) AA size battery which is **non**-rechargeable. When operating under average conditions the instrument is expected to have approximately 5 years of battery life; average conditions are considered to be a reed switch input from a Flomec flowmeter with no outputs used. High input frequencies (~1kHz and higher) from a turbine flowmeter will reduce battery life by around 20%, and operation of a battery powered scaled pulse output will reduce battery life by approximately 50%. When the NPN transistor is used for an alarm with infrequent operation the reduction of battery life may be negligible.

A low battery is indicated by the battery symbol on the lower line of the LCD display; illumination of this indicator shows that the battery should be replaced as soon as possible. Generally the remaining battery life after low battery indication is several days **however this is not guaranteed**. Replacement batteries are available from the instrument manufacturer or they may be purchased independently by the user (**safe areas only**). For user replacement it is recommended that a Tekcell SB-AA11 battery be used. Use of a battery which is not a 3.6V Lithium Thionyl Chloride type will void the instrument warranty.



CAUTION

For intrinsically safe instruments the approved intrinsically safe battery assembly (1412028-EX) must be used - see section 5 for details.

2.3.12 External DC Power

External DC power may be connected to the instrument in the range of 12-30V DC; this will activate the LCD backlight, the sensor supply, and the isolated output. When external DC power is provided the instrument will no longer draw any power from the battery – the battery will then only be used as a backup power source. With the battery in backup mode the life is expected to be approximately 8-10years.

2.3.13 Sensor Supply

The instrument is equipped with a regulated sensor supply (5V/20mA maximum) terminal which is suitable for powering hall-effect sensors in Flomec flowmeters. The sensor supply is only available when the instrument is connected to an external 12-30V DC supply, it is not available under loop power. 20mA of sensor current is available when the external DC supply is 24V or higher; Flomec flowmeters will only require 12V DC supply to the instrument.

3. Mechanical Installation

3.1 General Requirements

Installation of this product should only be carried out by suitably qualified/trained personnel with an understanding of local regulations regarding electrical installations, and if relevant Hazardous Area electrical installations.

It is recommended that the instrument is installed in a location where it is shielded from extreme varying weather conditions, and from chances of physical impact. Never install the instrument in an area which will expose it to temperatures outside its specified operating temperature range.

3.2 Conduit Entries

Each instrument is equipped with three conduit entries which are factory sealed to maintain the IP rating of the enclosure. To gain access to a conduit entry the integral moulded plug must be broken out of the electrical entry. Inserting a suitably sized screw driver or Allen-key into the centre of the conduit entry plug and bend the plug back and forth until it breaks away from the enclosure.

Always use IP rated cable glands when fitting cable to the instrument. If any electrical entries are opened using the method above and are later not used, these must be sealed using a threaded conduit plug with an appropriate IP rating (IP66 or IP67 is recommended)

3.3 Integral Meter Mounting

This instrument may be purchased as a meter mount display which will mount on the top of any Flomec flow meter. For any instruments purchased as field mount, these may be converted to a meter mount instrument by purchasing a new rear enclosure.

For mounting this instrument on a Flomec flowmeter with a process temperature of over 80°C/176°F (**70°C/158°F for intrinsically safe installations**) there is a 'Cooling Fin Kit' available from the manufacturer which will allow this; these may be retro-fitted in the field with minimal effort.

3.4 Wall and Pipe Mounting

Mounting of the instrument on a pipe or flat surface (such as a wall) can be accomplished using the Wall Mount Kit (**part no. 1522001**) or Pipe Mount Kit (**part no. 1522002**) – see next page for diagram.

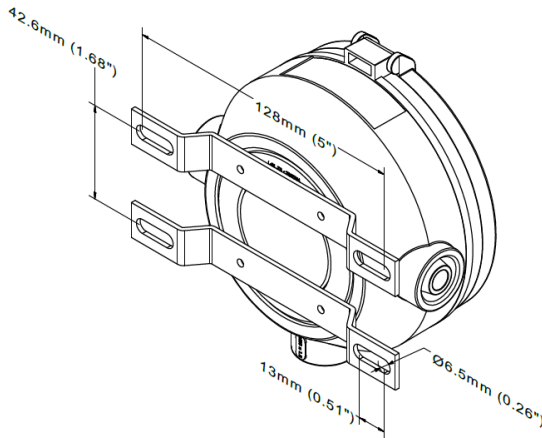

3.5 Panel Mounting

Mounting of the instrument in a panel requires a 106mm (± 2 mm) / 4.10" - 4.25" round hole to be cut in the panel – maximum panel thickness 6mm (1/4"). The Panel Mount Seal Kit (part no. 1504003) must be used to maintain weather protection when panel mounted. IP65 is possible with the seal kit used. If the instrument is installed indoors the instrument may be panel mounted without the seal kit.

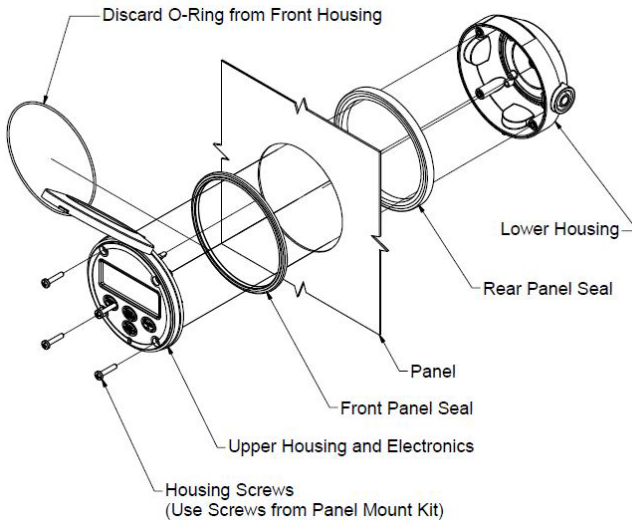

The rear enclosure of the instrument should be mounted behind the panel (*as per diagram above*) to protect the electronics module from damage and provide separation from any conductive components inside the panel/cabinet (**this is compulsory for intrinsically safe installations**)

4. Electrical Installation

All wiring connections should be made with good quality shielded instrument cable; wiring between terminals which are inside the instrument enclosure, or between a flowmeter and an integrally mounted instrument may use non-shielded wire. Cable shields or drain wires should be connected to the instrument ground (GND) at the instrument end only – isolate the shield/drain wire at the flowmeter end of the cable.

The terminal connections on the instrument will allow for usage of wiring up to 2.5mm² cross section (14AWG) – if two wiring connections into the same terminal are required the maximum cross section of each wire is 0.75mm². Wire insulation should be stripped to a length of 6.5mm and conductors should be fitted to the terminals so that there is minimal exposed conductor. Terminals can be tightened with a No.1 Phillips head screwdriver, or a 3mm or 1/8” flat blade screw driver.

Section 5 gives additional specific information for intrinsically safe installations and overrides any information in this section.

4.1 Terminal Identification

The terminal connections are divided into 4 separate sections by their function; all input terminals are on the left and all output terminals on the right - see below for more detail. There is a separate ground (GND) terminal in each section of terminals; as this instrument has a common ground, **all GND terminals are internally connected.**

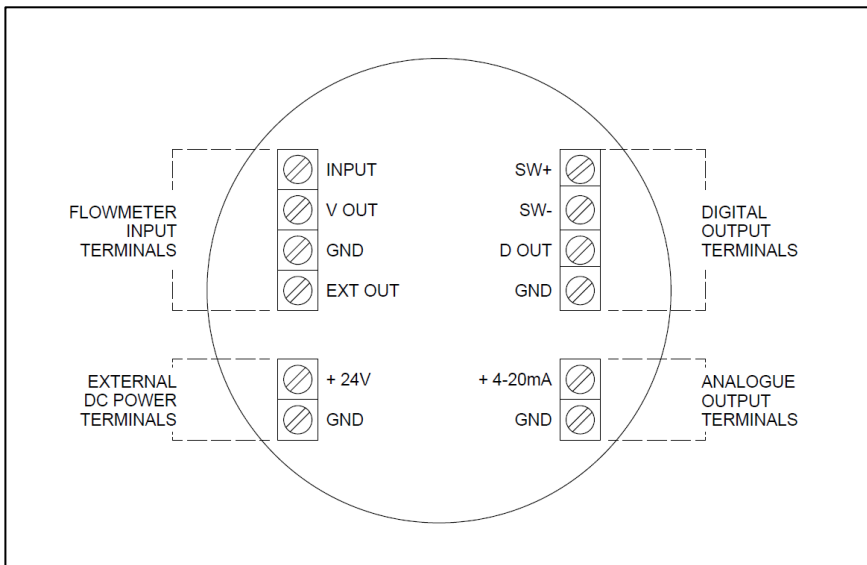

4.2 Input Connections

The input type must be set in the software before the below wiring connections will function

4.2.1 Reed Switch Input

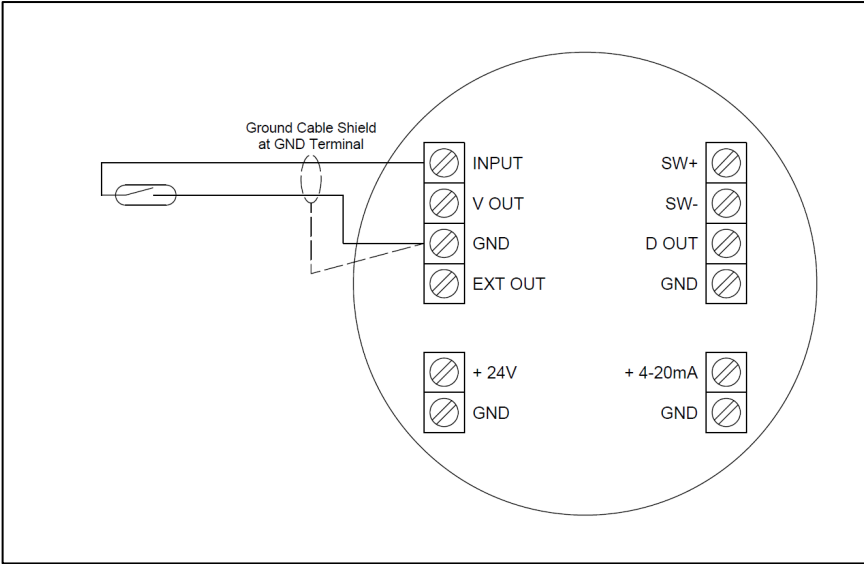

4.2.2 NPN Sensor Input (Hall Effect)

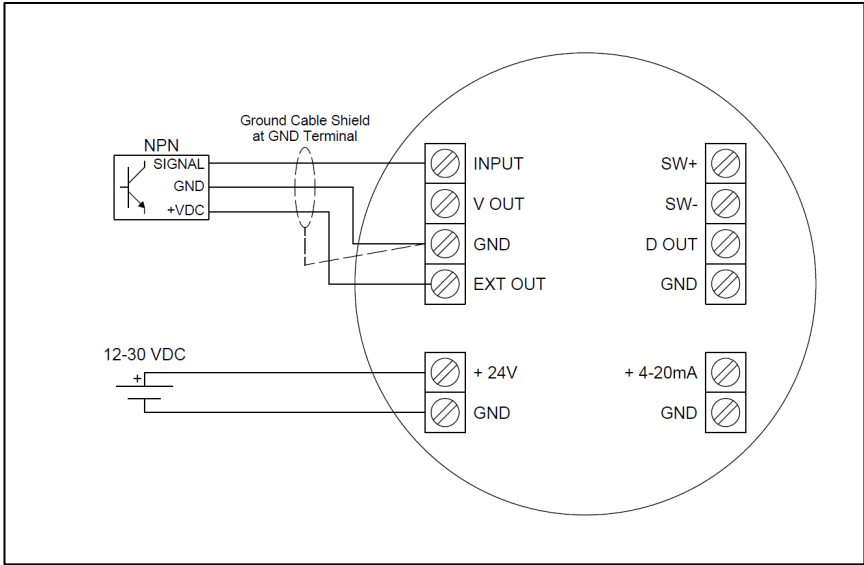

4.2.3 PNP Sensor Input

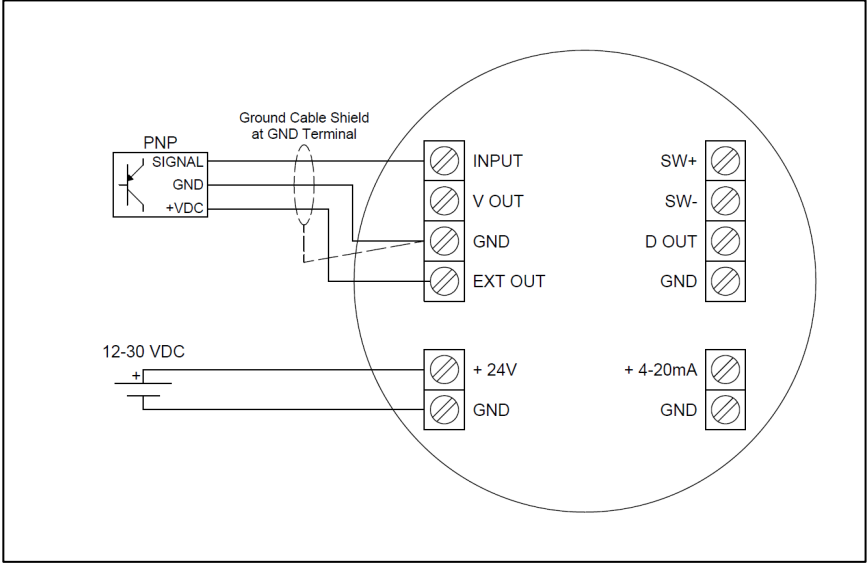

4.2.4 Voltage Pulse Input (Wiegand Sensor / DP Meters)

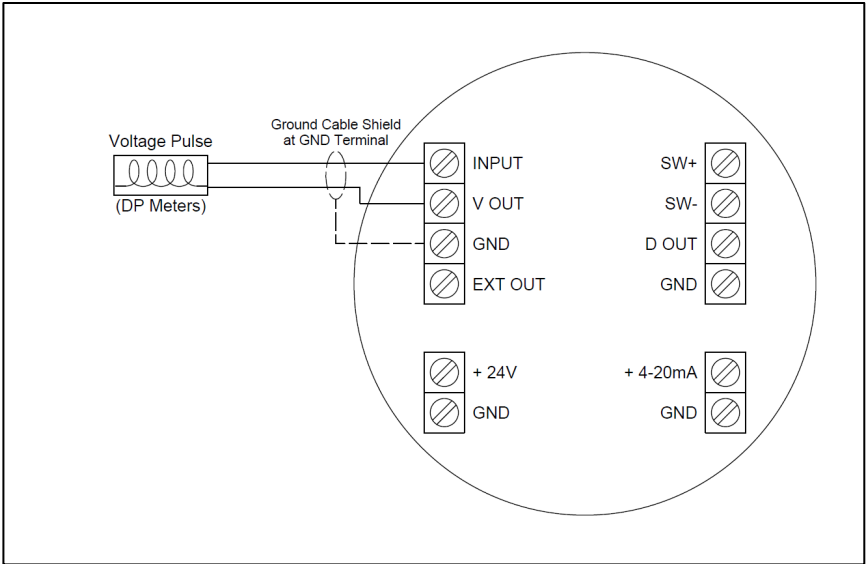

4.2.5 Variable Reluctance Coil Input (Turbine Meters)

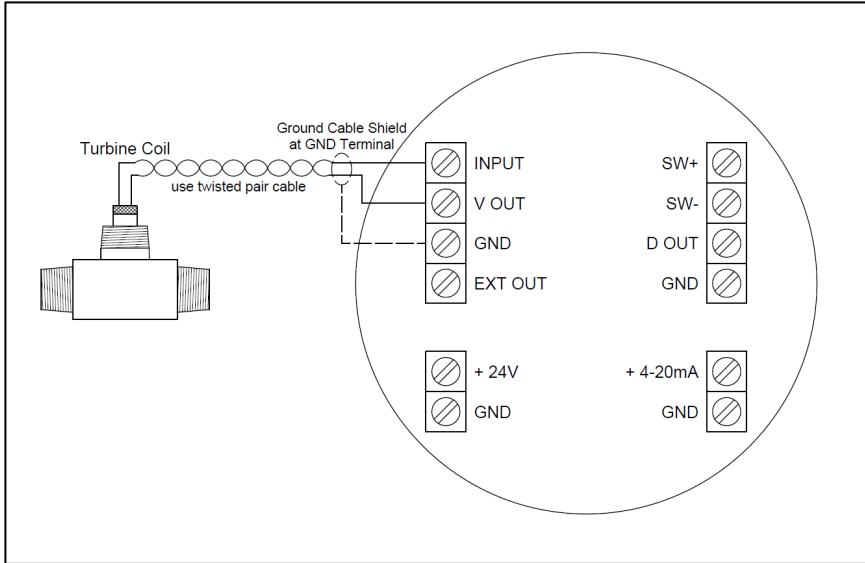

4.3 Output Connections

4.3.1 Passive NPN Digital Output with Unpowered Sensor

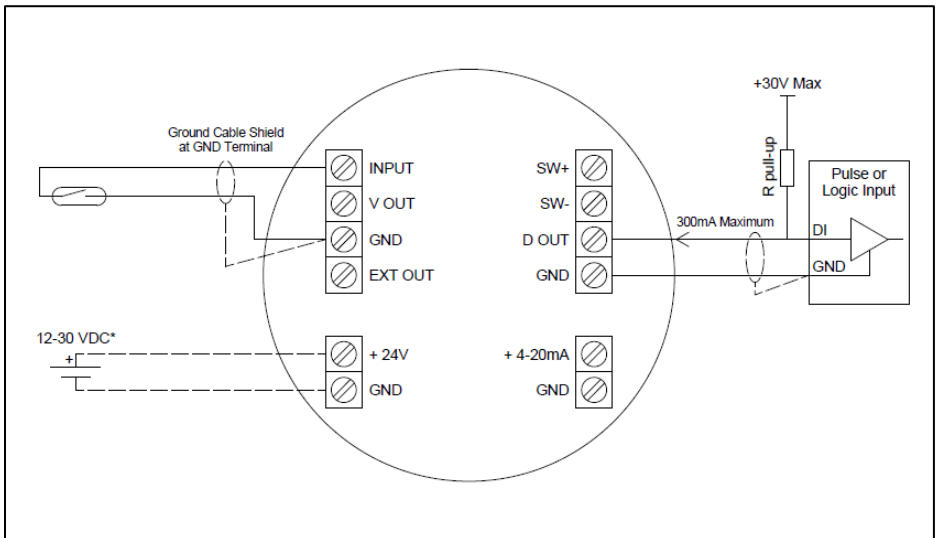

Notes: Shown here with Reed Switch input, Coil and Voltage Pulse inputs also suitable for this configuration. *External 12-30V DC power supply to instrument is optional.

4.3.2 Passive NPN Digital Output with Powered Sensor

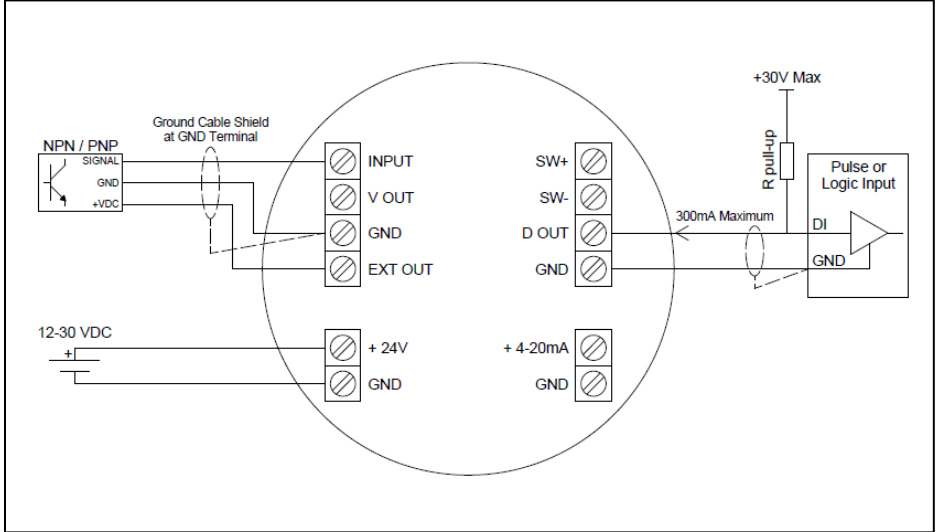

4.3.3 PNP Digital Output – configuration suitable for all input types

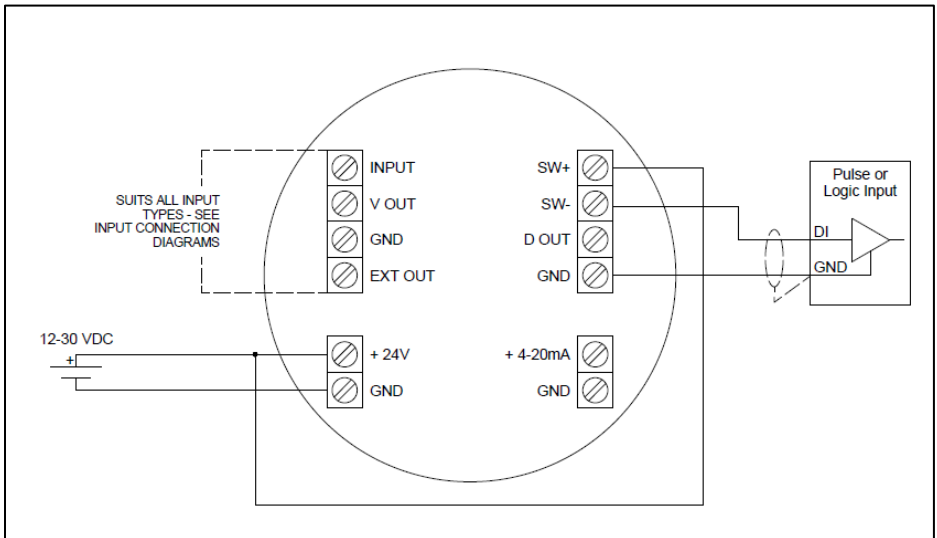

4.3.4 Digital Output to a Relay – Recommended connection for all 12-30V DC Relays

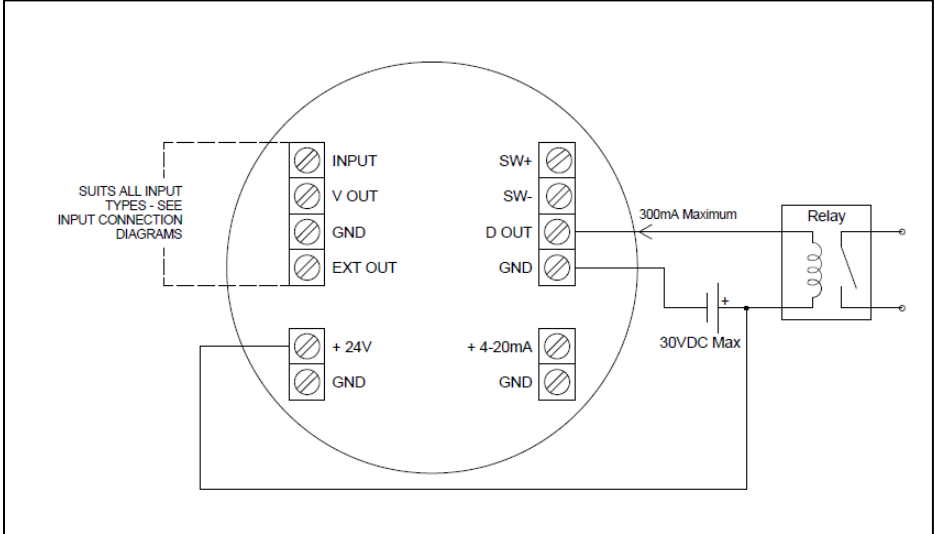

Note: Wiring connection from voltage supply to +24V terminal on instrument is not compulsory, however it will prolong battery life.

4.3.5 Digital Output to a Relay – For up to 50V DC and 50V AC Relays

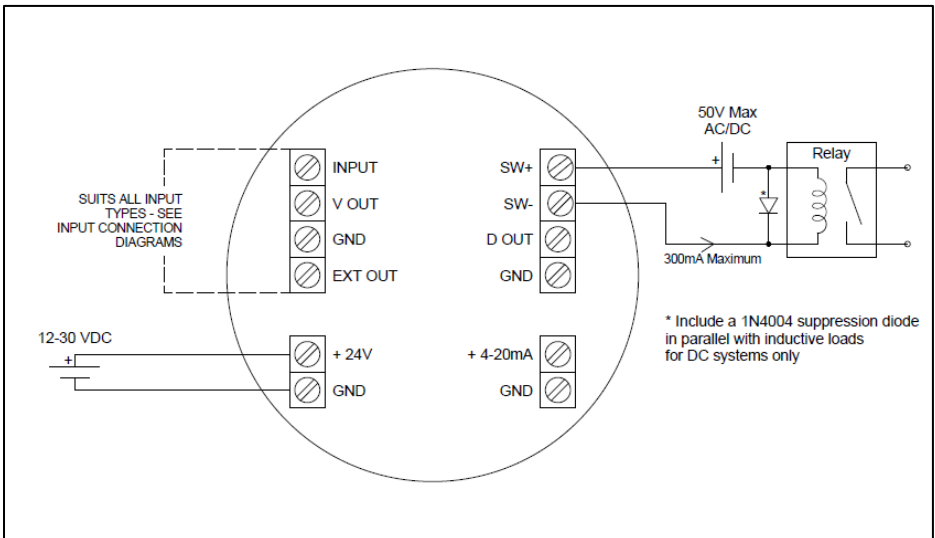

Note: This output type is not internally protected from voltage spikes from inductive loads, a diode must be fitted as shown for DC loads, or a Metal Oxide Varistor fitted for AC circuits.

4.3.6 Analogue Output with an Unpowered Sensor – Negative Reference

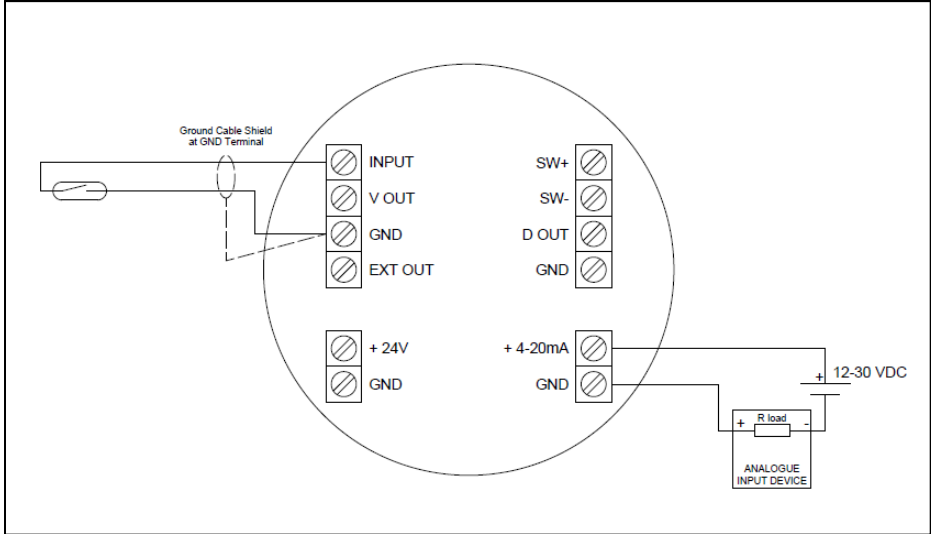

Notes: Shown here with Reed Switch input, Coil and Voltage Pulse inputs also suitable for this configuration.

4.3.7 Analogue Output with an Unpowered Sensor – Positive Reference

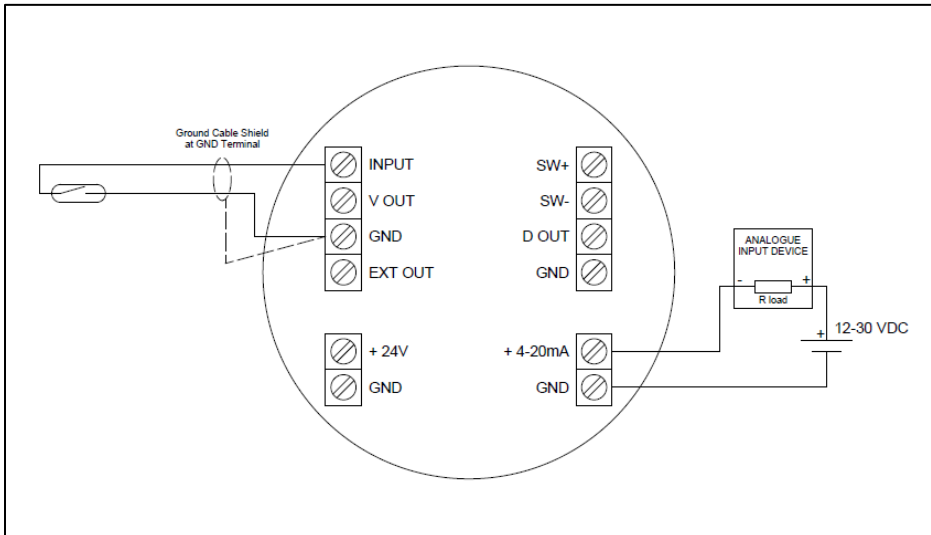

Notes: Shown here with Reed Switch input, Coil and Voltage Pulse inputs also suitable for this configuration.

4.3.8 Analogue Output with a Powered Sensor – Negative Reference

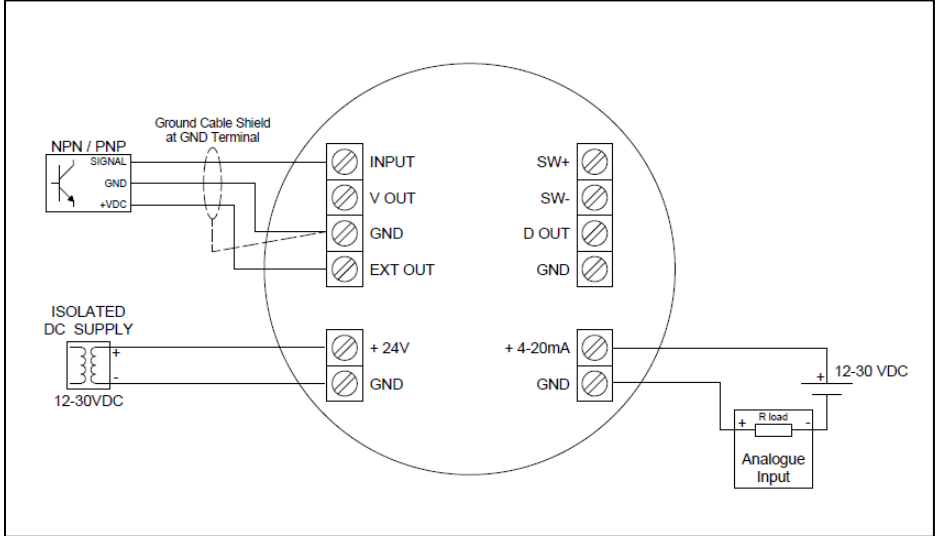

4.3.9 Analogue Output with a Powered Sensor – Positive Reference

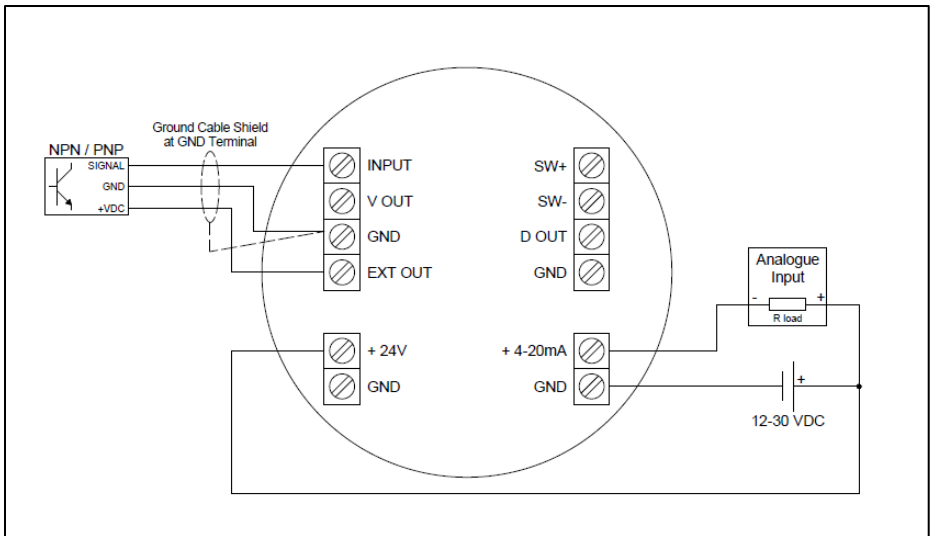

Note: Some instrumentation systems may have a common ground between the analogue input and the DC supply, for those systems this wiring configuration will not be possible and configuration 4.3.8 must be used.

4.4 Connections for Combined Outputs

4.4.1 Combined Analogue Output and NPN Digital Output to Common Receiver

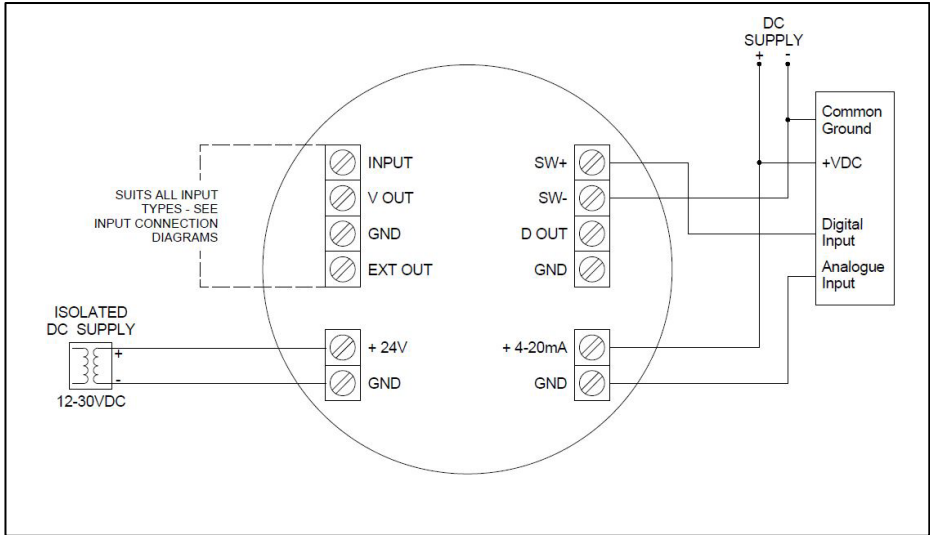

4.4.2 Combined Analogue Output and PNP Digital Output to Common Receiver

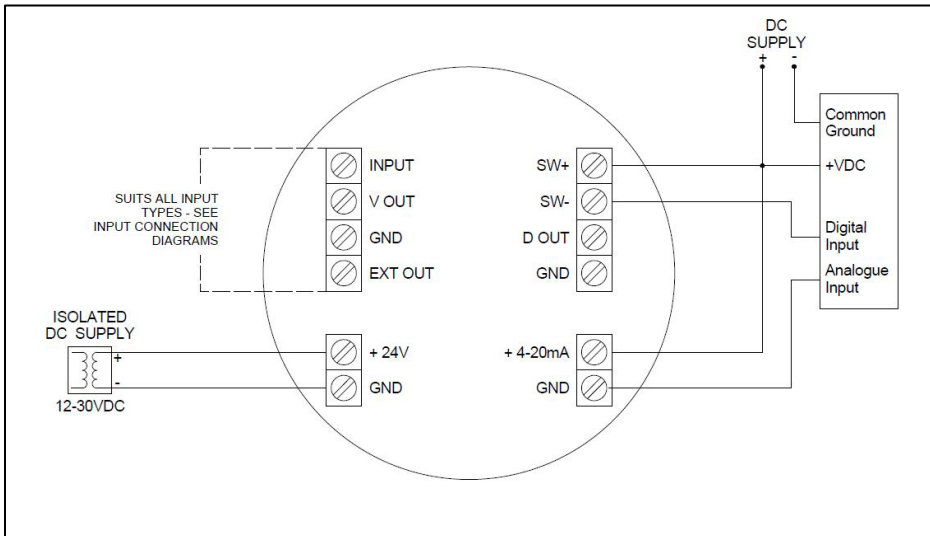



5. Intrinsically Safe Installations

5.1 General Information

- ⦿ *Mechanical and electrical installation of this product may only be completed by a trained and competent person authorised by the operator of the facility.*
- ⦿ *Personnel must read and understand this manual before carrying out any installation or operation of the product in a hazardous area.*
- ⦿ *For installation under the ATEX directive; this intrinsically safe device must be installed in accordance with the ATEX directive 2014/34/EU and the product certificate <certificate number>*
- ⦿ *For installation under the IECEx scheme; this intrinsically safe device must be installed in accordance with the product certificate <certificate number>*
- ⦿ *Special conditions of safe use mentioned in both the certificate and the installation instructions must be followed when connecting power to both input and/or output terminals.*
- ⦿ *When installing this device in a hazardous area, the wiring and installation must comply with all appropriate international/national and industry codes and standards. For example; in Canada, the Canadian Electrical Code, Part 1 Appendix F and in USA, the National Electrical Code, NFPA 70, Article 504 and ANSI/ISA-RP 12.6.*
- ⦿ *Due to risk of static discharge the enclosure should only be cleaned with an anti-static cloth dampened with soapy water.*

5.2 Label Information

 CAUTION
<p><i>Intrinsically safe installation is only allowed when the instrument is fitted with the label pictured below.</i></p>

TRIMEC INDUSTRIES PTY LTD CARINGBAH NSW AUSTRALIA		
	II 1 G Ex ia IIB T4 Ga -30°C ≤ Ta ≤ +70°C	IECEX KIWA 19.0018X KIWA 19ATEX0033 X
	<div style="border: 1px solid black; padding: 5px; display: inline-block;"> Warning: Refer to Installation Manual </div>	

5.3 Conforming Standards

This intrinsically safe instrument is certified in accordance with the ATEX directive and the IECEx scheme. Prior to installation or use review the approval markings on the product and in this manual, as well as the conforming standards below, to confirm it is appropriate for your country/region and site classification.

ATEX Directive

ATEX directive 2014/34/EU
EN 60079-0:2012 + A11 : 2013
EN 60079-11:2012

IECEx Scheme

IEC 60079-0:2011 Edition 6.0
IEC 60079-11:2011 Edition 6.0

5.4 Intrinsically Safe Electrical Installation



CAUTION

When two or more active intrinsically safe circuits are connected to the instrument, take precautions to separate the circuits in accordance with IEC 60079-11



CAUTION

Hazardous Location Apparatus – switches, thermocouples, or non-inductive resistance devices, or Certified Apparatus must be connected in accordance with the manufacturer's installation instructions

5.4.1 Simple Apparatus Reed Switch Input

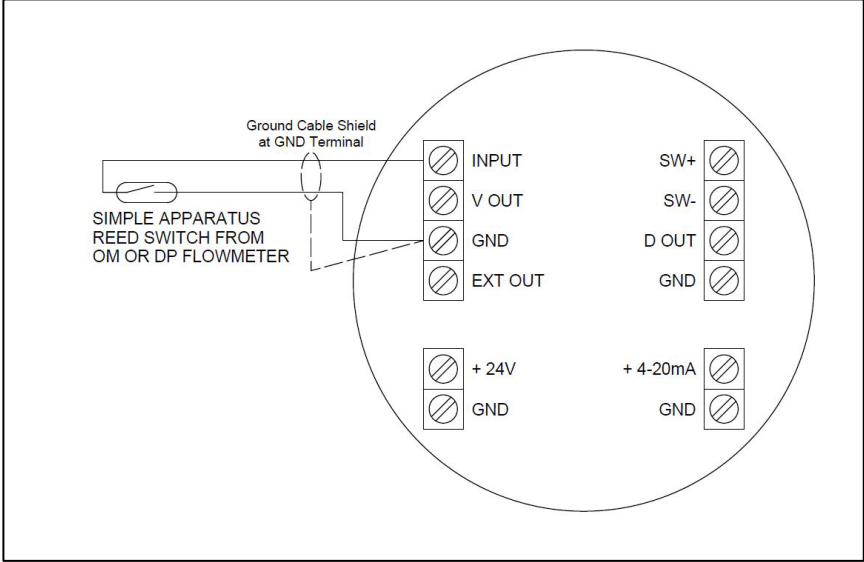

5.4.2 Intrinsically Safe Variable Reluctance Coil Input

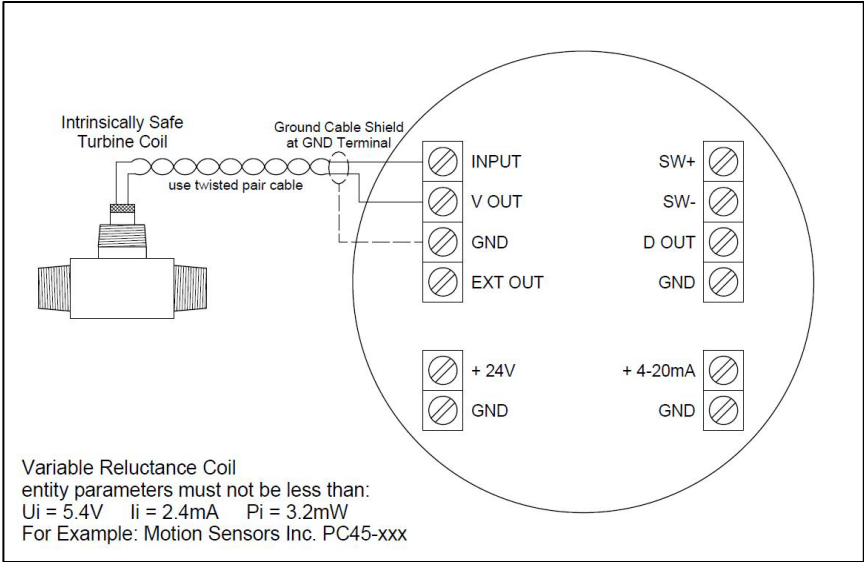

5.4.3 Intrinsically Safe Powered Sensor Input

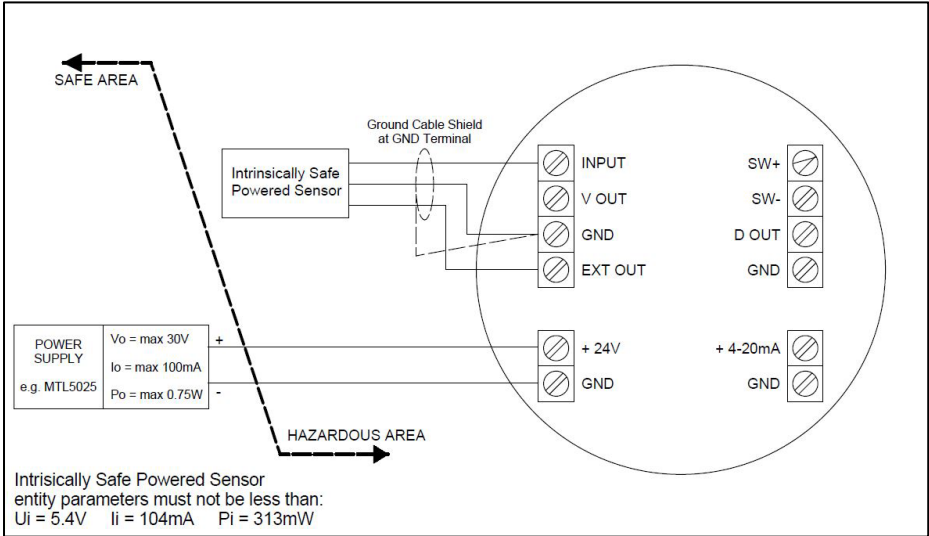

5.4.4 Output Connections

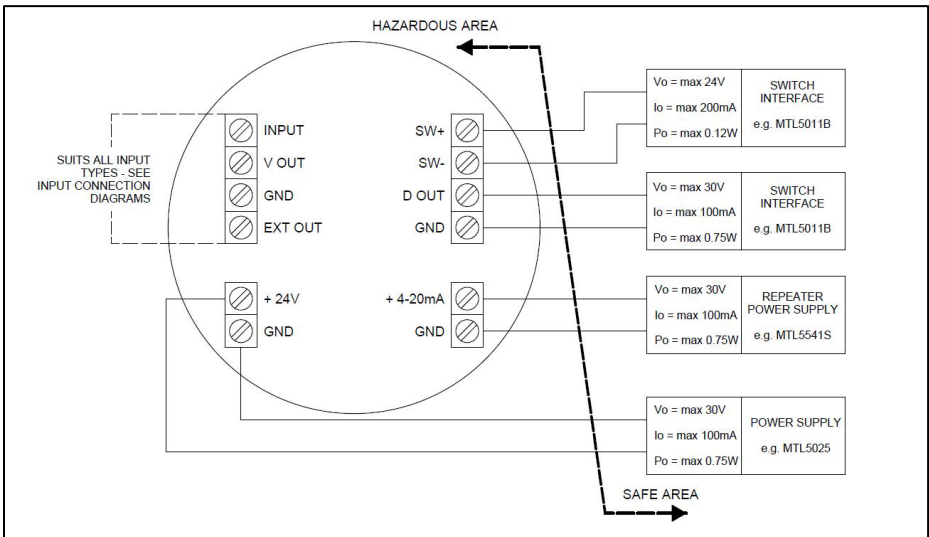

5.5 Intrinsically Safe Battery Replacement

- ⚙ **Battery replacement may only be completed by a trained and competent person authorised by the operator of the facility.**
- ⚙ **Intrinsically safe battery may be replaced in a hazardous area.**
- ⚙ **Fire, explosion, or severe burns may result of the battery in this product is mistreated. Do not recharge, crush, disassemble, incinerate, heat above 100°C (212°F), or expose the contents of the battery to water.**



Do not dispose of used battery assemblies as trash or incinerate due to environment hazards. Return used batteries to a recycling point.



CAUTION

When replacing the battery in this product, only the certified intrinsically safe battery assembly (part number 1412028-EX) manufactured by Trimec Industries Pty. Ltd. may be used.

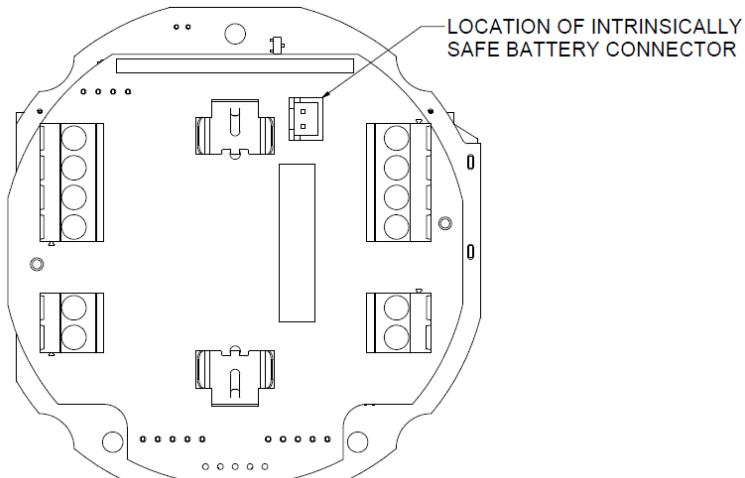
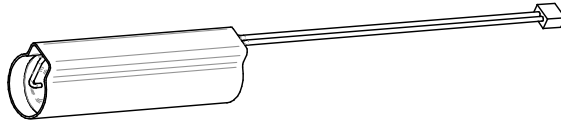

5.6 Service and Repair

The only serviceable items within the instrument are the external fasteners, O-ring seals, the decal, and the battery pack (which may be replaced as per section 5.5 above). All replacement items for intrinsically safe instruments must be purchased from the manufacturer – failure to do so will void the product’s certification and warranty.

The instrument cannot be repaired by the user, damaged or non-functioning instruments must be replaced by a new certified product. The instrument may only be repaired by the manufacturer.

6. Programming Parameters

6.1 PIN Program Protection

Any user defined PIN other than 0000 will engage the program protection mode; after the PIN protection mode is enabled failure to input the correct PIN number will deny the user the ability to change any of the program parameters, but will allow read only access to the user so that they may view existing program settings.

Only one PIN may be set at any one time, but this can be changed at any time by entering the programming mode, entering the existing PIN, and then changing the PIN to a new number. A second backup PIN exists in the software which can be used should the user programmed PIN be lost – contact the manufacturer should you require the backup PIN.

6.2 Engineering Units

The engineering units for the instrument may be selected from any of the following; Litres, millilitres, cubic Metres, kilograms, Gallons, Quarts, Pounds, or none. The unit ‘none’ is used where the user requires a unit other than those available and the number of pulses / unit are known for the required unit – *for example US Barrels can be used by selecting the units as ‘none’.*

The Total and Rate units are programmed separately, and may be selected as separate units, for example millilitres for total, and L/hr for the flowrate. When the selected Total unit and the selected Rate unit are both units of volume, or are both units of mass (e.g. Litres and Gallons, kilograms and pounds) the instrument will calculate the difference without further user input. However when the units are a mixture of volume and mass, the user must enter their own rate conversion factor.

6.2.1 Rate Units Conversion

The Rate Conversion Factor is calculated as the quantity of Rate units per Total unit – see the following chart for some examples:

Total Unit	Rate Unit	Density	Conversion Factor
Kilograms	Litres	1200kg/m ³	1.200
Litres	Kilograms	1200kg/m ³	0.833
US Barrels (none)	Gallons	N/A	42.000

6.3 Time-base for Rate

The time-base for the Rate display may be selected from any of the following; units/second, units/minute, units/hour, units/day. The Rate time-base setting will determine the units used in programming the analogue output set points.

6.4 Decimal Places

Decimal places are separately adjustable for Total, Accumulated Total, and Rate from zero to three decimal places. The decimal places setting for Rate will set the available decimal places in the analogue output set point. The decimal place settings for Total and Accumulated Total do **not** influence configuration of the pulse output.

6.5 K-Factor Entry

The K-factor entry screen allows entry of up to 7 whole numbers and 4 decimals, however only the first 7 significant digits are used by the software in calculating totals. When entering the K-factor screen not all available digits are shown; moving the cursor to the right will show the remaining available digits. **Note that when different engineering units are configured for Total and Rate, the K-factor should be entered in the engineering units which are selected for Total.**

6.6 Input Type Configuration

The input type can be selected from the following; Reed switch, NPN, PNP, or Coil. The following table should be referenced when selecting the correct software setting for your flowmeter. **Instruments delivered integrally mounted to a flowmeter will have this parameter factory set and do not require user adjustment.**

Sensor Type	Used in:	Software Setting	Maximum Frequency
Reed Switch	Oval Gear Meters Paddle Wheel Meters	REED	120Hz
NPN Sensor	Oval Gear Meters Paddle Wheel Meters (hall effect sensor)	NPN	1.2kHz
PNP Sensor	Other manufacturer's Flow Meters	PNP	1.2kHz
Variable Reluctance Coil	Turbine Flowmeters	Coil	2kHz
Wiegand Sensor	Paddle Wheel Meters - Voltage Pulse	Coil	2kHz

6.7 Non-Linearity Correction

Non-linearity correction (NLC) allows the instrument to correct for known inaccuracies in a flow-meter, thereby improving the overall measurement accuracy, and in many cases

increasing the effective flow range of the measurement system. Non-linearity correction can be used on battery power however battery life will be reduced according to usage.

Non-linearity correction functions as an intermediate process between the receiving of input pulses and the calculation of totals; therefore all subsequent processes such as Rate calculation, analogue output calculations, and pulses/alarm outputs are also corrected according to the settings programmed for the non-linearity correction.

The non-linearity correction function is programmed using up to 10 frequency points, and a K-factor for each frequency point. Not all 10 points must be used, however a minimum of 2 points is required. Below the minimum frequency point the instrument will use the K-factor entered for the lowest point, similarly above the maximum frequency point the instrument will use the K-factor entered for the highest point. Linear interpolation is used between frequency points.

If any frequency in the programming menu is entered as zero Hz then all remaining frequency points will be disabled; i.e. if data is entered for points '0F' to '4F' and point '5F' is entered as 0Hz, points '6F' to '9F' will not be used. Once the non-linearity correction function is enabled the general K-factor entered at Level 5 of the program is disabled; if the non-linearity correction is later disabled the instrument will revert to the general K-Factor.

Data for entry of Non-Linearity Correction is available for Flomec meters when purchased with a multi-point factory calibration. Alternatively NLC data can be obtained with a field calibration of the meter.

6.8 Digital Output

The digital output function is configurable for either a pulse output according to totalised flow, or an alarm output according to flowrate. The pulse output can be configured for an unscaled pulse or a scaled pulse, and the alarm can be configured for notification of high flowrates, low flowrates, or a combination of both.

6.8.1 Un-Scaled Pulse

The unscaled pulse output, also commonly referred to as a 'repeater pulse' is enabled by selecting 'UNSCALED' in the digital output configuration menu.

6.8.2 Scaled Pulse

The scaled pulse output is enabled by selecting 'SCALED' in the digital output configuration menu. Configuration of this output is accomplished by entering the number of units per output pulse; e.g. 10 Litres/pulse, 0.1kgs/pulse, etc. The engineering units configured for the Total display are used to specify the settings for this output. The range of available settings for this output are from 0000.01 units/pulse up to a maximum of 9999.99 units/pulse.

As there is a frequency limitation on the scaled pulse output of 100Hz it is preferred to configure the scaled pulse output to keep the output frequency below this limit. If it is necessary for the scaled pulse output to operate at greater than 100Hz the instrument will output the signal at the maximum of 100Hz, and all excess pulses will be stored in memory until such a time that flow has stopped and the instrument can output the stored pulses – it is not recommended that systems be designed to operate in this way under normal conditions.

The output frequency can be calculated as follows:

$$\text{Frequency} = \frac{\text{Maximum Flowrate (units per minute)}}{\text{Output Scaling Factor (units per pulse)} \times 60(\text{seconds per minute})}$$

If the system design does not allow significant periods of zero-flow where the instrument can reduce the stored pulse count to zero it is advisable to increase the number of units/pulse in order to keep the output below 100Hz.

6.8.3 Flow Alarm

The Alarm output is enabled by selecting 'ALARM' from the digital output configuration menu. The alarm output may be configured as a 'High Alarm' which will trigger in the event the flow rate exceeds the alarm set-point, a 'Low Alarm' which will trigger in the event the flow rate drops below the set-point, or a 'High/Low Alarm' which is a combination of the two.

Configuration of the Alarm involves selecting the type of alarm, entering the alarm set-point (*specified in Rate units, e.g. L/min*), and entering the alarm dead-band. The Alarm dead-band is an adjustable buffer zone around the set point which provides hysteresis to the system, and allows the user to overcome alarm chattering when the flowrate is fluctuating around the set-point. The dead-band setting is entered as a percentage of the set-point value; e.g. a 5% dead-band around a 100L/min High Flow Alarm will trigger ON at 100L/min but will not turn OFF until the flow drops to below 95L/min.

6.9 Analogue Output

The 4-20mA analogue output can be configured anywhere within the operating range of the connected flowmeter; a 22mA over-range is provided for identification of flows exceeding the maximum flowrate of the connected flow meter.

The output is configured in flowrate units for the zero point (4mA) and the full scale point (20mA). The decimal places allowed for the set points are equal to the decimal place configuration of the Rate display. The 4mA and 20mA points may be entered upside-down, i.e. a 20mA point lower than the 4mA point. **For information on testing or adjustment of the 4-20mA signal see section 5.10.5 below.**

6.10 Advanced Menu

6.10.1 Resetting Accumulated Total

Resetting the accumulated total can only be done at this level of the Advanced Menu; by PIN protecting the instrument it is possible to remove the ability of an operator to reset the accumulated total. Once the accumulated total is reset it is not possible to recover the value which was in the accumulated total – it is advisable to record the accumulated total value before resetting.

6.10.2 Rate Damping

Flow Rate Damping is used to smooth out fluctuating flow input signals in order to provide a stable Rate Display and Analogue Output. Most input signals are reasonably stable and need only the default Rate Damping setting, however for systems with large flow fluctuations the Rate Damping setting may need to be increased.

If the user requires quick visual indication of changes to a system's flowrate (*either on the Rate Display, or in the Analogue Output*) this can be accomplished by reducing the Rate Damping setting. To remove all damping from the flow rate calculation Rate Damping can be set to zero.

6.10.3 Low Frequency Cut-Off

The low frequency cut-off parameter is used to adjust the minimum frequency required for the rate display and analogue output functions. This setting is useful to avoid spikes in the rate display and analogue output from "apparent flow" which could be caused by movement of liquid in the pipes of a mobile installation (on a truck etc.), pulsations from a dead-headed pump, etc.

The default value for the low frequency cut-off is 0.2Hz, and the parameter is adjustable from 0.1Hz up to 9.9Hz. It is not possible to enable a rate display or analogue output for input frequencies below 0.1Hz.

6.10.4 Rate Calculation Pulses

The purpose of the 'Rate Calculation Pulses' parameter is to determine the number of input pulses which are used in calculation of the flow rate; the more pulses which are used the more accurately the Rate Display will represent the **average** flow-rate of the system. The parameter is adjustable from 1 to 255 pulses per calculation. For systems using pumps with a non-uniform rate of delivery (*piston pumps or similar*) it is important to have a high value for this parameter as it will produce a stable rate display and analogue output which is representative of the average flow through the pipe.

For systems with a steady and uniform flow through the pipe, lower values can be used for this parameter in order to achieve a more responsive rate display and analogue output.

However it should be kept in mind that for any battery powered applications, using a value lower than the default will decrease battery life.

6.10.5 Analogue Output Adjustment

The analogue output may be adjusted/trimmed at this level of the program; this should not be necessary in most applications as the analogue output is factory calibrated, however it may be useful when operating at extreme ambient temperatures.

There are two parameters which the user can set; the 4mA adjustment and the 20mA adjustment. With the 4mA adjustment showing on the instrument display the unit will output 4mA to the receiving instrument, likewise with the 20mA adjustment showing on the display the unit will output 20mA. By noting the difference in the receiving instrument's reading in mA the user can correct any errors.

The display allows entry of the adjustment in 0.001mA steps, and adjustments may be made in the positive or negative direction. ***The default adjustment direction is positive, however this can be changed by holding the 'UP arrow' key for 3 seconds.***

6.10.6 Backlight Override

The backlight is automatically enabled whenever external DC power is connected to the instrument; this feature may be over-ridden in this level of the program. The backlight override may be set to 'ON' (normal function), 'OFF' (always off), or 'INT' (intermittent, the backlight will be on for 30 seconds following a button press). Note that 'INT' operation still requires external DC power.

6.10.7 Tag Number Entry

The user may enter an identifying tag number into the instrument, according to the P&ID of the installation where it is used. The default tag number is FIT-000 allowing quick entry of a simple ISA-5.1 standard Tag Number, however this can be expanded up to 12 digits of alphanumeric characters and hyphens (*e.g. FIT-123-45AB*). The leading 3 digits (FIT; describing the device as a Flow Indicator/Transmitter) may also be changed to any alphanumeric character to suit the user's requirements.

Once a tag number is entered it is viewed during the operating mode by pressing and holding the PROG/ENTER key; when the tag number contains more than 8 digits it will scroll across the LCD.

7. Programming Flowchart

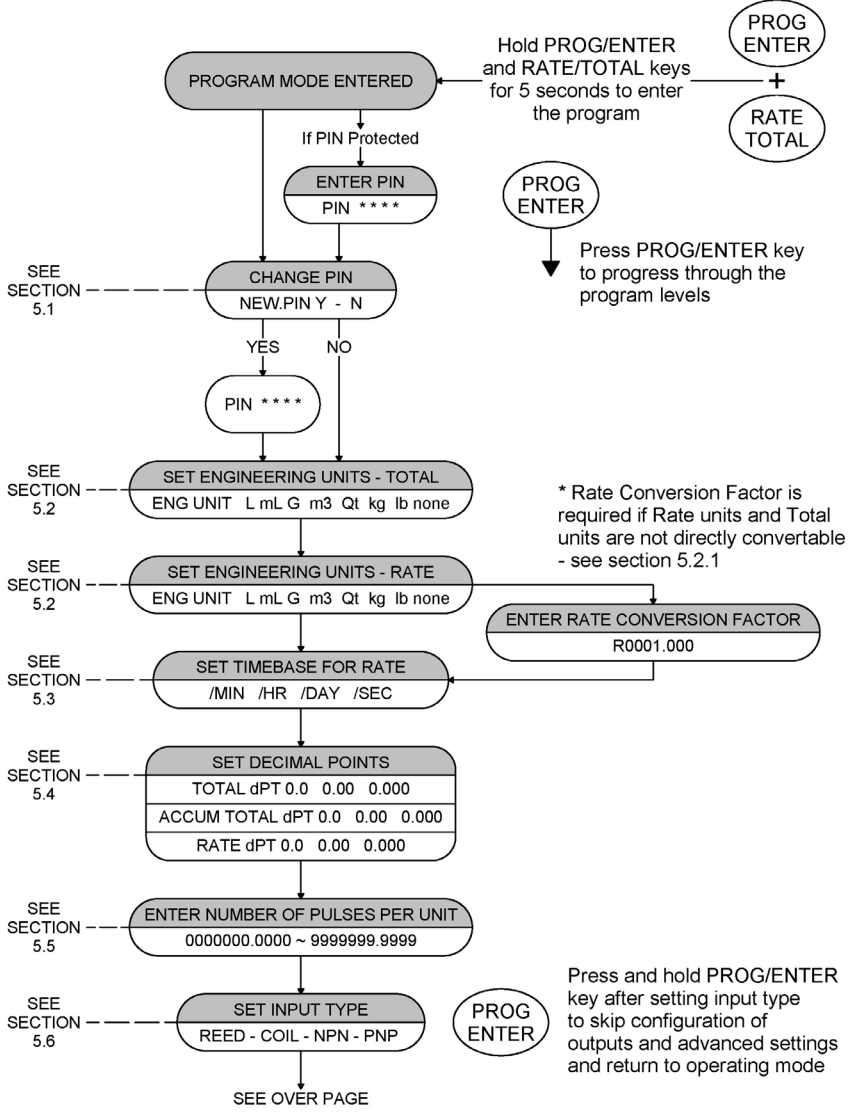

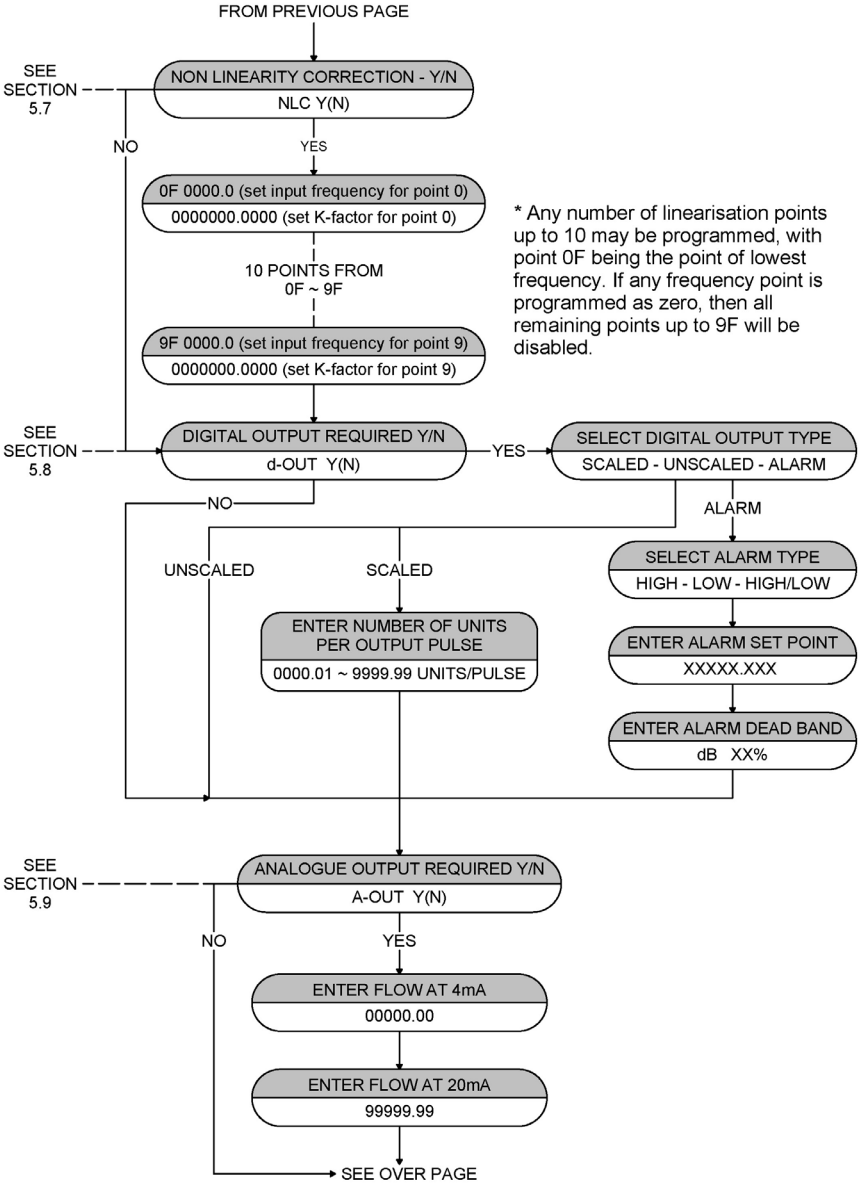

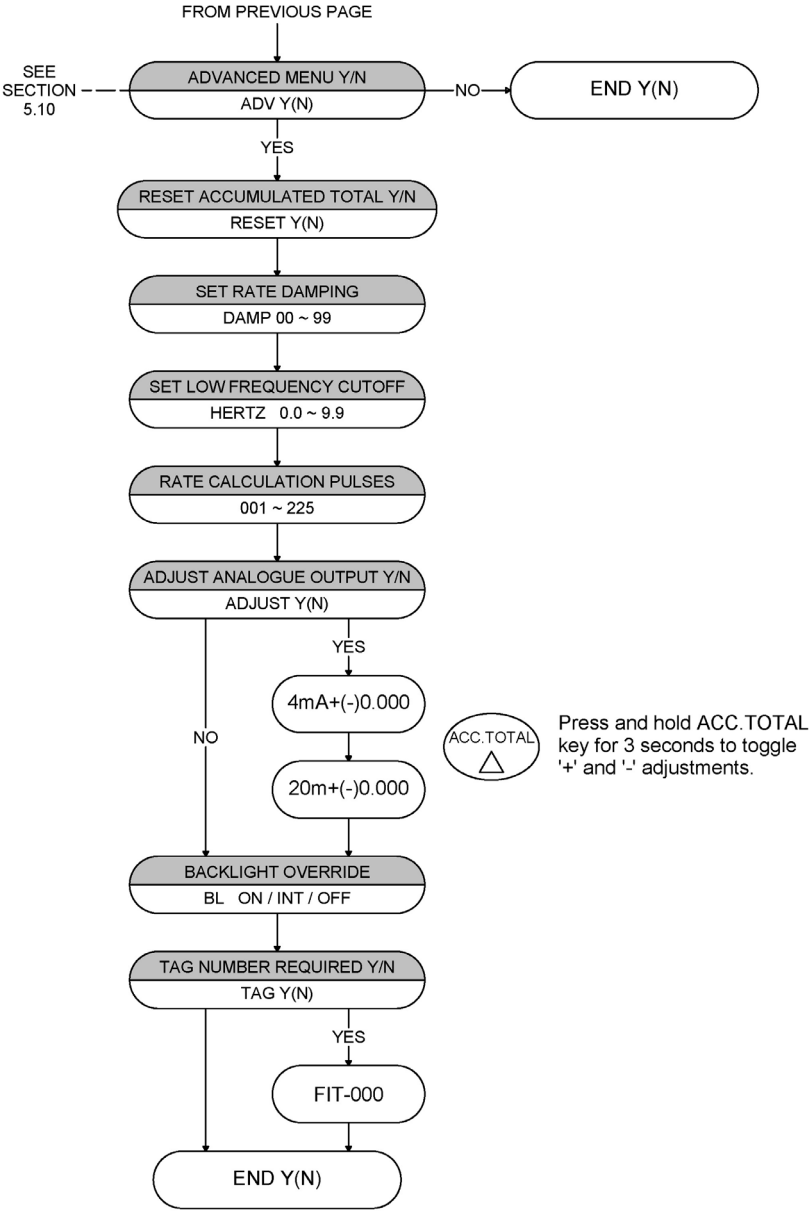

8. Program Detail Record

User PIN										
Engineering Units	Total									
	Rate									
Rate Conversion Factor		<input type="checkbox"/>	Yes	<input type="checkbox"/>	No	RCF =				
Time Base for Rate		<input type="checkbox"/>	/Sec	<input type="checkbox"/>	/Min	<input type="checkbox"/>	/Hr	<input type="checkbox"/>	/Day	
Decimal Points	Total	<input type="checkbox"/>	0	<input type="checkbox"/>	0.0	<input type="checkbox"/>	0.00	<input type="checkbox"/>	0.000	
	Accum. Total	<input type="checkbox"/>	0	<input type="checkbox"/>	0.0	<input type="checkbox"/>	0.00	<input type="checkbox"/>	0.000	
	Rate	<input type="checkbox"/>	0	<input type="checkbox"/>	0.0	<input type="checkbox"/>	0.00	<input type="checkbox"/>	0.000	
K-Factor (pulses / unit)		K =								
Input Type		<input type="checkbox"/>	Reed	<input type="checkbox"/>	Coil	<input type="checkbox"/>	NPN	<input type="checkbox"/>	PNP	
Non Linearity Correction		<input type="checkbox"/>	Yes	<input type="checkbox"/>	No					
Point 0F					Hz	K =				
Point 1F					Hz	K =				
Point 2F					Hz	K =				
Point 3F					Hz	K =				
Point 4F					Hz	K =				
Point 5F					Hz	K =				
Point 6F					Hz	K =				
Point 7F					Hz	K =				
Point 8F					Hz	K =				
Point 9F					Hz	K =				
Digital Output		<input type="checkbox"/>	Yes	<input type="checkbox"/>	No					
Digital Output Type		<input type="checkbox"/>	Unscaled	<input type="checkbox"/>	Scaled	<input type="checkbox"/>	Alarm			
Units per Output Pulse							<input type="checkbox"/>	N/A		
Alarm Set-Point		High:				Low:				
Alarm Dead-Band		DB%:								
Analogue Output		<input type="checkbox"/>	Yes	<input type="checkbox"/>	No					
Zero Set-Point (4mA)		4mA@								
Full Scale Set-Point (20mA)		20mA@								
Rate Damping										
Low Frequency Cut-off										
Rate Calculation Pulses										
Backlight Setting										
Tag Number										

9. Spare Parts

Spare parts for your instrument are available from the local dealer or national distributor from whom you purchased the instrument; see spare parts list below to determine which parts numbers you require.

Description:	Includes:	Part No:
Bezel Cover Assembly	1 x Bezel Cover Assembly with magnet	1406011
Front Housing Kit	Complete replacement front housing with clear lens and keys. Facia not included	1502058
Meter Mount Rear Housing Kit (M20)	Rear housing for meter mounted instrument (M20 entries). Includes the required fasteners and seals for meter mounting	1502001
Meter Mount Rear Housing Kit (NPT)	Rear housing for meter mounted instrument (NPT entries). Includes the required fasteners and seals for meter mounting	1502002
Field Mount Rear Housing Kit (M20)	Rear housing for field mounted instrument (M20 entries)	1502003
Field Mount Rear Housing Kit (NPT)	Rear housing for field mounted instrument (NPT entries)	1502004
Complete Fastener Kit	All internal and external fasteners, including meter mount screws.	1508128
Faceplate Screw Kit	4 x Faceplate screws including o-ring seals	1508129
Housing Seal	BS046 Buna-N (Nitrile) O-Ring	BS046B
Meter Mount Seal	BS039 Buna-N (Nitrile) O-Ring	BS039B
Facia Sticker (Decal)	Self-adhesive facia (decal) with Flomec logo	1315147
Safe Area Battery	3.6V AA Lithium Battery	1312035
<i>Alternative Replacement Battery for Safe Area Units Only</i>		Tekcell SB-AA11 Tadiran TL5903/S
I.S. Battery	Replacement battery for Intrinsic Safety	1412028-EX
Wall Mount Kit	2x wall mount brackets, 4 mounting screws	1522001
Pipe Mount Kit	Wall mount kit plus pipe clamps	1522002
Panel Mount Seal Kit	Front and rear panel seals, 4x screws	1504003



CAUTION

Use of a battery which is not a 3.6V Lithium Thionyl Chloride type in a Safe Area instrument will void the instrument warranty.

Use of a battery other than the approved Intrinsically Safe battery (1412028-EX) in an Intrinsically Safe instrument will impair intrinsic safety

10. EU Declaration of Conformity

Product Models: RT141D0FM RT141D0FM-I (*intrinsically safe*)
RT141D0MM RT141D0MM-I (*intrinsically safe*)
RT142D0FM RT142D0FM-I (*intrinsically safe*)
RT142D0MM RT142D0MM-I (*intrinsically safe*)

Manufacturer: Trimec Industries Pty. Ltd.
12/7-11 Parraweena Road
Caringbah, NSW 2229
Australia

This declaration of conformity is issued under the sole responsibility of the manufacturer. Conformity is based on the application of the harmonised standards listed below, and where necessary through certification by a European Union Notified Body.

2014/30/EU EMC Directive

Harmonised standards: EN61000-6-2:2005, EN61000-6-3:2007, EN61326-1:2013

2011/65/EU RoHS Directive

Harmonised standards: EN IEC 63000:2018

2014/34/EU ATEX Directive (*intrinsically safe option ‘-I’ only*)

ATEX certificate: KIWA 19ATEX0033X

Harmonised standards: EN60079-0:2012+A11:2013, EN61000-11:2012

Notified Body for ATEX Type Examination: CSA Group Netherlands B.V. (NB No. 2813)

Notified Body for ATEX QAN: CSA Group Netherlands B.V. (NB No. 2813)

Signed for and on behalf of the manufacturer:



Matthew Wyres,
General Manager
Trimec Industries Pty. Ltd.

Sydney, Australia
27th October 2023

Notes:

A large, empty rectangular box with a thin black border, intended for handwritten notes.

Notes:

A large, empty rectangular box with a thin black border, intended for handwritten notes.



Service & Warranty

For Technical Assistance, warranty replacement or repair in North or South America contact your Flomec Distributor or contact

Great Plains Industries, Inc.
5252 East 36th St. North Wichita,
KS, USA 67220-3205

888-996-3837

For Technical Assistance, warranty replacement or repair outside North or South America contact your Flomec Distributor or contact

GPI Australia
(Trimec Industries Pty. Ltd.)
12/7-11 Parraweena Road
Caringbah NSW 2229
Australia

+61 02 9540 4433

www.flomec.com.au
www.flomecmeters.com