

THS23/24



2-wire Temperature & Humidity Transmitter for Indoor / Duct OEM Type

APPLICATIONS

Features

- 2-wire loop design.
- Compact design, good look and easy to install.
- An economical choice, high C/P ratio.
- Foreign-made sensor component with high accuracy and long-term stability.
- OEM type, MOQ: 20 pcs.

Applications

- Monitoring for HVAC process / air conditioning / environmental ventilation control.
- Environmental monitoring for building / factory / clean room / Lab.
- Monitoring for storeroom / crisper / agriculture / food industry.
- Temperature and humidity measuring in hospital / pharmaceutical industry / textile industry.



THS 23	-	A	1	1	-	30	-	E
Installation	Function		Output	Power Supply	Temperature Range	Option		
23 : indoor 24 : duct-mounting	A : temperature & humidity output		1 : 4~20mA	1 : 24 VDC±15%	30 : 0~50°C	E : none		

DIMENSION

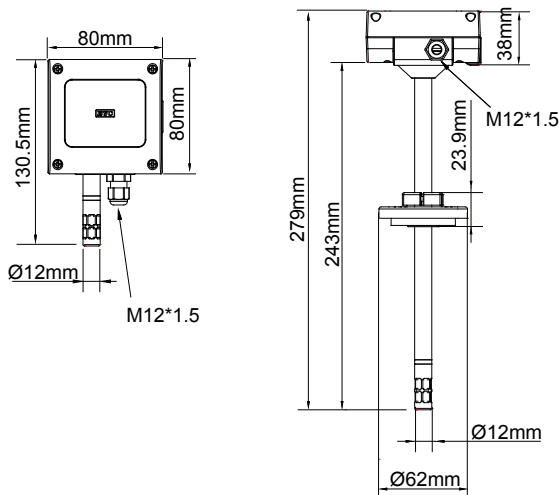

THS23

THS24

CONNECTION DIAGRAM

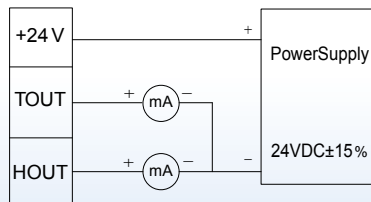

4-20mA (2-wire)

TECHNICAL SHEET

INPUT

Input..... capacitive humidity sensor & PT 100 Ω
 Measuring range.....temperature: 0~50°C ; humidity : 0~100%
 Working range.....temperature: 0~50°C ; humidity : 5~95%

OUTPUT

Output..... 4~20mA ; 2-wire

ACCURACY (at 25°C)

Temperature±0.5°C
 Humidity..... ± 3%RH (10~90%)
 Load resistance ≤ 500Ω
 Output calibration (ZERO & SPAN) adjustment range
10% of zero-point and full-range
 Response time t90 (at 25°C) < 20S

ENVIRONMENT

Media measured..... air
 Working temperature 0~50°C
 Working humidity..... 0~95 % (non-cond.)
 Storage temperature.....-25~60°C

ELECTRICAL REGULATION

Power supply 24VDC ±15%
 Electrical connection..... TS-504-3P connector
 Installation indoor / duct-mounting
 Protection degree IP 54 (Sensor: IP 20)
 Electrical protection polarity protection
 Certification..... CE
 Housing PC fire-proof class
 Probe PC fire-proof class
 Packing..... 20 pcs/CTN
 Weight THS23: 117g / THS24: 162g