



FEATURES

- Build-in Laser Trim ASIC
- Easy to change range
- ON-OFF or time proportional selectable
- Compact, only 65mm in depth
- Wide selection of control output option
- Wide selection of ranges
- Sensor break protection
- Alarm option (BTC-704, BTC-702 Only)
- Low cost
- Safety: UL, CSA
- EMC, LVD: CE

SPECIFICATIONS

INPUT

Thermocouple (T/C) : Type J, K
 RTD : 3-wires PT 100 ohms, DIN or JIS
 Range : See ordering information
 Accuracy : $\pm 2\%$ of span (BTC-701, BTC-702),
 $\pm 1\%$ of span (BTC-704)
 Cold Junction Compensation : $\pm 0.1^\circ\text{C} / 1^\circ\text{C}$
 Rejection of RTD Lead Resistance =
 (0.1 $^\circ\text{C}$ -0.025% of PV reading ohm)
 Sensor Break Protection : Upscale
 External Resistance : 100 ohms max.
 Normal Mode Rejection : 60 dB
 Common Mode Rejection : 120 dB
 Sample Rate : 3 times / second

CONTROL

Proportional Band : 2.2% of span
 ON-OFF Hysteresis : 1 % of span
 Cycle Time : 20 seconds for relay output,
 1 second for pulsed voltage output,
 0.02 second for linear current or voltage output.
 Control Action : Reverse action

OUTPUT

Control : Relay : 5A/240V max. resistive load
 Pulsed Voltage : 20mA / 32VDC max.
 Current : 4-20mA, 0-20A, max. load 500 ohms.
 Voltage : 0-10V, min. load 500k ohms
 Alarm : Relay output, 2A / 240VAC max. resistive load

ADJUSTMENT

Set point : Single turn wirewound potentiometer
 Alarm : Deviation alarm, adjustable $\pm 10\%$ of span
 Manual Reset : Adjustable 2.6% of span (BTC-702, 704 only)
 Resolution of set point : 0.2% of span
 Accuracy of set point : $\pm 2\%$ of span
 Repeatability of set point : $\pm 0.1\%$ of span

INDICATION

Process Indicator : BTC-702 : Deviation meter
 BTC-704: 10mm red 3-1/2 digit LED display
 Status Indicator : ON (red) LED Lamp
 Alarm Indicator : ON (red) LED Lamp

POWER

Rating: 90~240VAC, 50/60Hz
 Consumption: Less than 5VA

ENVIRONMENTAL & PHYSICAL

Operating Temperature : 0-50 $^\circ\text{C}$
 Humidity : 0-90% RH (non-condensing)
 Insulation : 20M ohms min. (500VDC)
 Breakdown : AC 2000V, 50/60Hz, 1 minute
 Vibration : 10-55Hz. amplitude 1 mm

BTC-704, BTC-701

Shock : 200M/S² (20g)

Weight : BTC-701: 290 grams, BTC-702: 320 grams,

BTC-704: 240 grams.

Dimension : 72 (W) X 72 (H) X 65mm (depth behind panel)

Panel cutout : 68 X 68mm

CONNECTION DIAGRAM

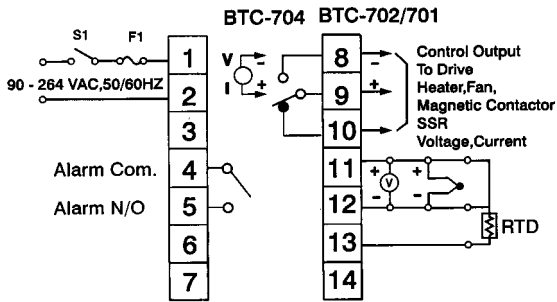

ORDERING INFORMATION

Model NO.
 (1) (2) (3) (4) (5) (6) (7) (8)

(1) Power Input

4	90-240VAC, 50Hz/60Hz
9	Other

(2) Signal Input

1	Type J thermocouple	4	PT 100 ohm JIS
2	Type K thermocouple	9	Other
3	PT100 ohm DIN		

(3) Range Code

Code	Range	Code	Range	Selected Solder GAP
2	0 ~ 100°C	A	50 ~ 20°F	J3
3	0 ~ 200°C	B	50 ~ 40°F	J4
4	0 ~ 300°C	C	50 ~ 55°F	J5
5	0 ~ 400°C	D	50 ~ 750°F	J6
		E	50 ~ 850°F	J7
6	0 ~ 600°C	F	50 ~ 1100°F	J8
7	0 ~ 800°C	G	50 ~ 1400°F	J9
8	0 ~ 1200°C	H	*0 ~ 2200°F	J10
9	Other	K	50~199.9°F	
		L	0~99.9°C	
		M	0~199.9°C	

(4) Control Mode

Code	Mode	J11
1	ON-OFF	Short
2	P (proportional)	Open

(5) Output I

1	Relay, rated 5A/240VAC resistive
2	Pulsed voltage to drive SSR, rated 20mA/24V
3	4-20mA linear, max. load 500 ohms
4	0-20mA linear, max. load 500 ohms
5	0-10V linear, min. load 500k ohms
9	Other

(6) Output II

0	None
---	------

(7) Alarm

0	None
1	Deviation alarm relay output, rated 2A/240VAC max. resistive load

(8) Communication

0	None
---	------

FUNCTION OF SOLDER GAP J1~J11

Location	Short	Open	Function
J1	o		T/C Type J or K
"		o	PT 100 ohms DIN or JIS
J2		o	Reverse Control
"	o		Forward control
J3	o		100°C span
J4	o		200°C span
J5	o		300°C span
J6	o		400°C span
J7	o		460°C span
J8	o		600°C span
J9	o		800°C span
J10	o		1200°C span
J11	o		ON-OFF control
"		o	Time proportional control

FUNCTION OF SOLDER GAP J12-J13

J12	J13	Cycle time	Function
Short	Short	20 Secs.	Relay output
Open	Short	1 Sec.	SSR drive
Open	Open	0.02 Sec.	Linear current or voltage output

* Please refer detailed conversion from full technical information