

EX80 Series

ELECTROMAGNETIC FLOW SENSOR INSTRUCTIONS



EX81
EX82

EX80 SERIES ELECTROMAGNETIC FLOW SENSOR INSTRUCTIONS

SeaMetrics

The Leader in Flow Meter Value.

TABLE OF CONTENTS

General Information

Modularity, Output, Insertion Depth, Fittings, Parts Diagram **Page 1**

Installation

Distorted Flows, Fitting Installation, Meter Installation, Positioning the Meter **Page 2**

Straight Pipe Recommendations **Page 3**

Full Pipe Recommendations **Page 4**

Electrical Connections

General Electrical Guidelines, Power, Forward Flow Output, Reverse Flow Output,
Grounding Guidelines, Grounding Diagram **Page 5**

Connections Diagrams

Counter or PLC, A055 4-20 mA Output, FT520 Controller **Page 6**

FT420 Display and Proportional Feed, FT420 & 4-20 mA Output, FS30 Flow Switch **Page 7**

DL75, FT420/DL75, Dual FT420 Displays (example of bidirectional connection) **Page 8**

Operation & Maintenance

Zero Adjustment, Minimum Flow, Flow Rate Table, Presence of Flow Indication,
Filtering, Electrode Coating, Calibration (“K-Factor”), K-Factor Chart **Page 9**

Troubleshooting

Problems, Probable Causes and Things to Try **Back**

TABLES AND DIAGRAMS

Parts Diagram **Page 1**

Distorted Flows, Positioning the Meter **Page 2**

Straight Pipe Recommendations **Page 3**

Full Pipe Recommendations **Page 4**

Grounding Diagram **Page 5**

Counter or PLC, A055 4-20 mA Output, FT520 Controller **Page 6**

FT420 Display and Proportional Feed, FT420 & 4-20 mA Output, FS30 Flow Switch **Page 7**

DL75, FT420/DL75, Dual FT420 Displays (example of bidirectional connections) **Page 8**

Flow Rate Table, K-Factor Chart **Page 9**

Troubleshooting Problems, Probable Causes and Things to Try **Back**

GENERAL INFORMATION

The EX80-Series are electromagnetic insertion flow sensors for use in conductive liquids in pipe sizes 1" to 10" (25mm to 250 mm.) Lacking moving parts, they are well suited for applications with particulates in the fluid that are problematic for impellers or turbines. Other advantages are insensitivity to viscosity and tolerance for pulsating flows such as with air-driven diaphragm pumps.

Modularity. Simplicity and modularity are at the core of the EX80 design. The basic flow sensor has one output, which is pulse proportional to flow rate. The FT420 module can be added to provide indication, 4-20 mA, and flow rate setpoints. The AO55 adds 4-20 mA analog only (blind transmitter). The FS30 is a flow switch module, and the DL75 is a datalogger. Any of these modules can be ordered pre-installed on the flow sensor or in a wall mount housing, and any can be retrofitted to the EX80-Series sensor in the field. The EX80 is also compatible with the FT520 batching flow processor.

Output. The basic pulse signal is compatible with many controls, with PLC's and irrigation or water treatment controllers being the most common. For these applications it is sometimes necessary to add a pull-up resistor, if the controller is not designed for a current-sinking input. See the section on "Connecting to PLC's and other Controllers" before connecting to a non-SeaMetrics control.

Insertion Depth. Like all insertion flow sensors, the EX80-Series extend into the pipe and measure the velocity of the fluid in a particular area of the pipe. The chosen insertion depth is the "critical point", or the area of the flow stream which maintains the average velocity across a wide range of flow rates. This is necessary because the shape of the velocity profile changes as the rate increases. (It transitions from a "bullet" to more of a "plug" shape).

Fittings. Since the EX80-Series sensors are not adjustable, they must be purchased with fittings appropriate to the application. The EX81 is sized for fittings of 1" to 3". The EX82 is for fittings of 4" to 10". Each fitting insures that the flow sensor is installed at the correct point. Every flow sensor and every tee fitting is wet calibrated. Saddle fittings are normally not wet calibrated, because they are field-installed on a pipe. In PVC however it is possible to order a saddle pre-installed on a standard length of pipe, in which case the entire assembly is wet-calibrated. For all other saddles, the K-factor (pulses per gallon), established through testing with various standard schedules of pipe, is provided with the saddle.

EX80 PARTS DIAGRAM

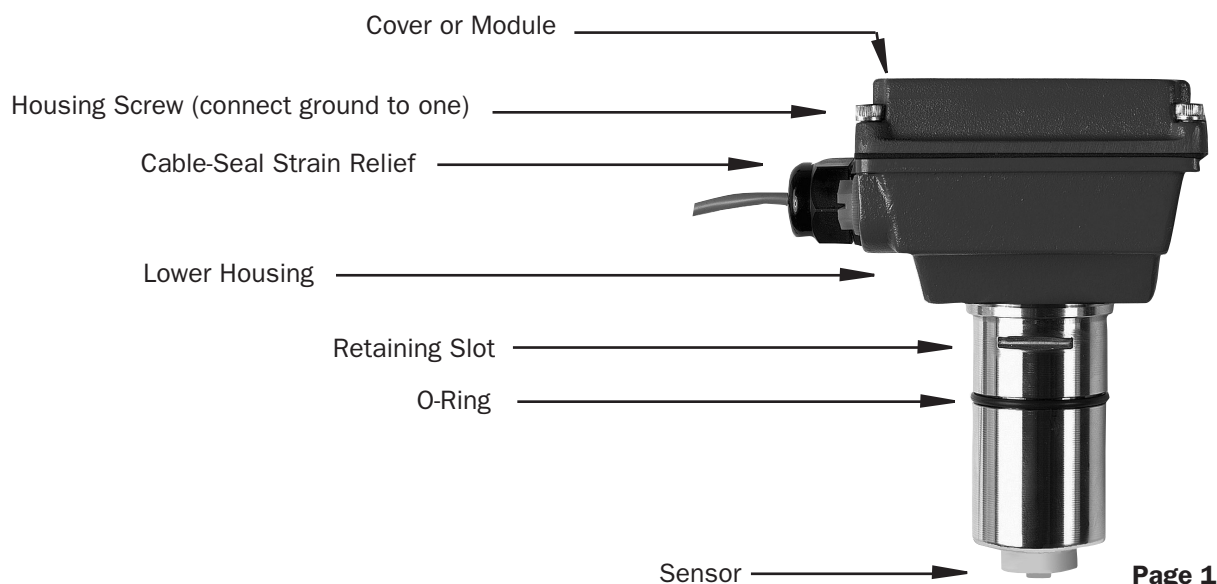

INSTALLATION

DISTORTED FLOWS

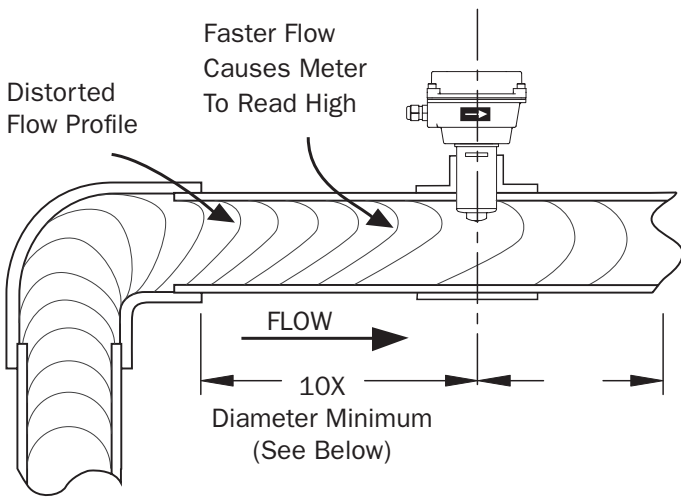

Fitting Installation. EX80 Series meters require special fittings. The meter fitting must first be installed in the pipeline. Straight pipe of at least ten times the diameter upstream of the meter and five diameters downstream is strongly recommended in order to achieve proper accuracy. These are minimum values. As the diagrams on the next page will show, you may need more straight run under specific adverse circumstances.

If you can't provide enough run to smooth out the turbulence caused by valves, fittings, and changes in direction, some decrease in accuracy may result. This does not mean that the flow meter's reading is meaningless, however. In some applications (for instance, where the flow meter is part of a control system, operating a valve or controlling chemical addition), a repeatable reading may be more important than a highly accurate one.

EX80 Series PVC meter tees are supplied with some upstream straight pipe. The length provided may be less than ten diameters upstream and five downstream. It is not advisable to connect directly to the end of these fittings with a flow-disturbing device such as a valve or elbow. If possible, straight pipe should be added to the upstream end of these fittings.

A PVC fitting is usually installed by solvent welding. The stainless steel and brass meter fittings have female pipe threads, requiring the appropriate male threaded fittings. Saddle fittings (size 3" and above) require a hole to be cut in the pipe. The recommended hole size is 1-3/4".

Meter Installation. After the meter fitting is installed in the pipeline, the meter can be installed in the fitting. After noting the direction of the flow arrow, press the meter into the fitting as far as it will go. Retain the meter in place by inserting the u-pin. The pin can be installed from either side. It may be necessary to rotate the probe back and forth slightly to start the pin into the slots on the probe. Slide the pin in as far as it will go.

POSITIONING THE METER

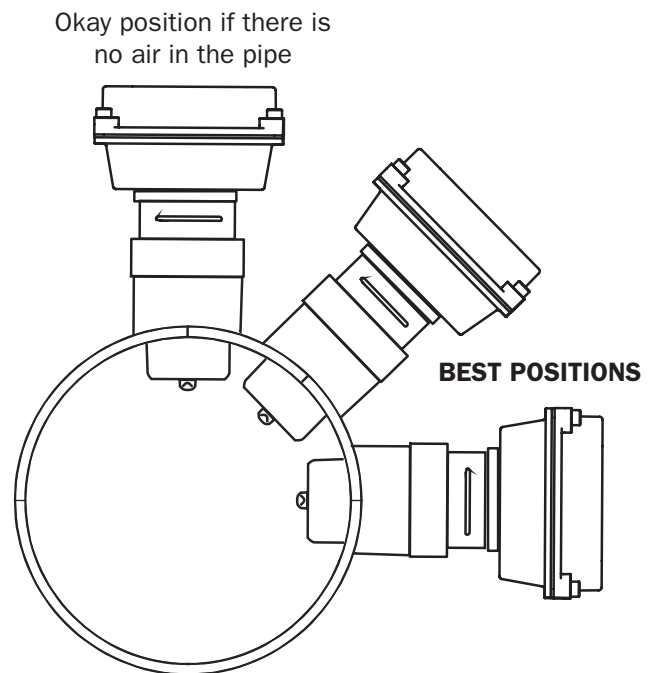

Caution: Never remove the u-clip retainer when the pipe is under pressure. Always remove pressure from the pipe before you attempt to remove the meter. Removal under pressure may result in damage or serious injury.

INSTALLATION

STRAIGHT PIPE RECOMMENDATIONS

(X = diameter)

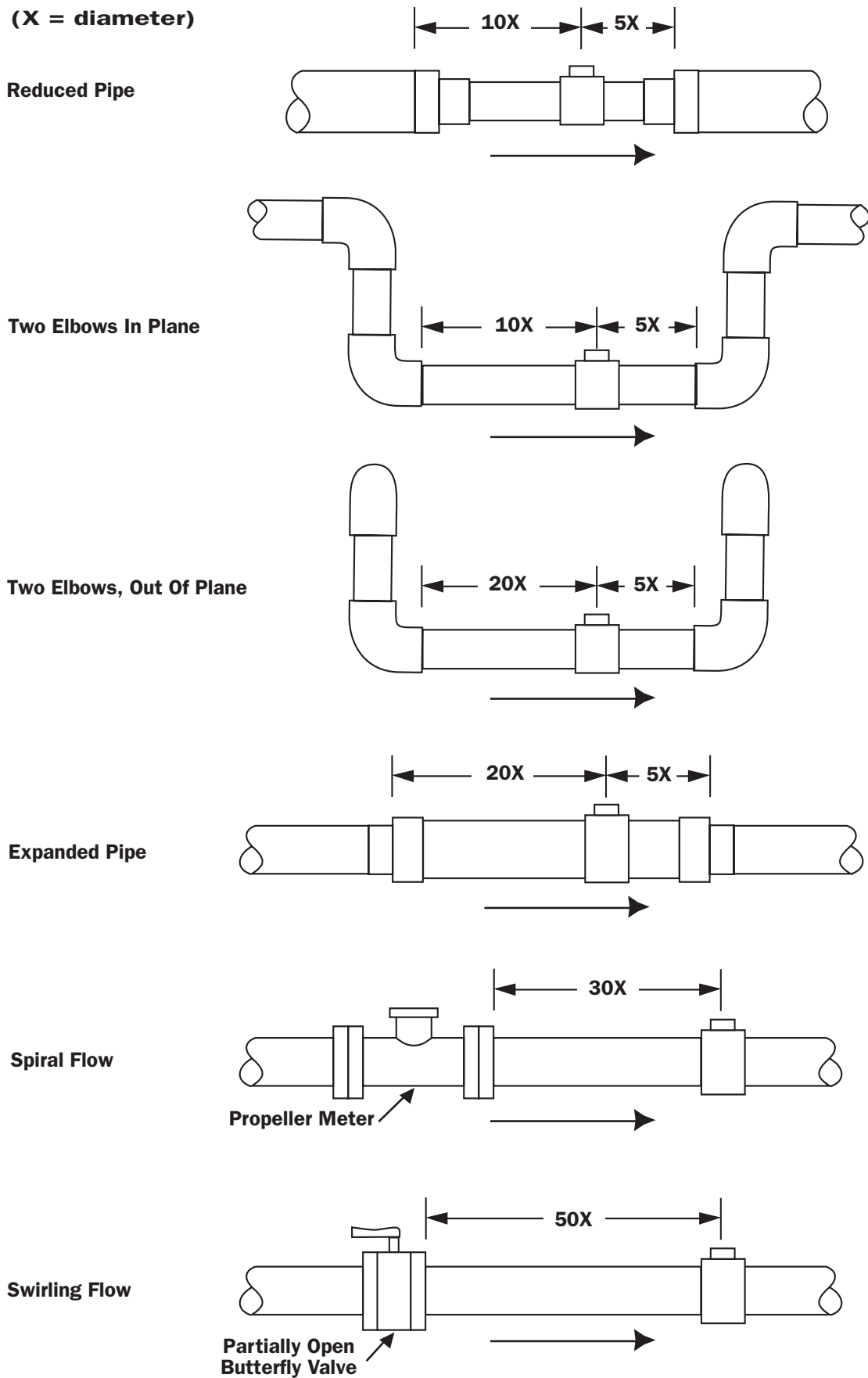

INSTALLATION

FULL PIPE RECOMMENDATIONS

NOT RECOMMENDED

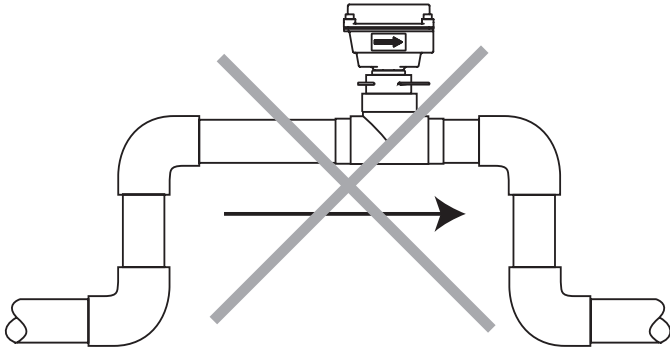

Allows air pockets to form at sensor

RECOMMENDED

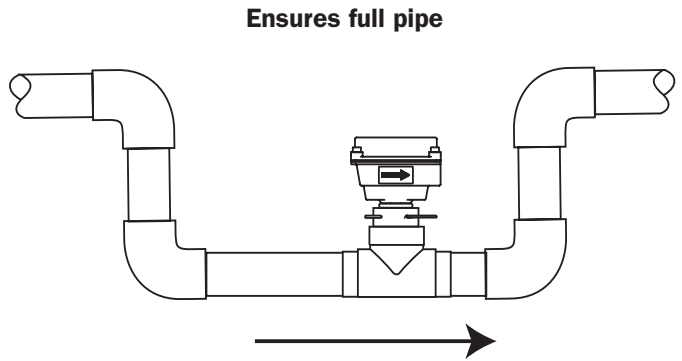

NOT RECOMMENDED

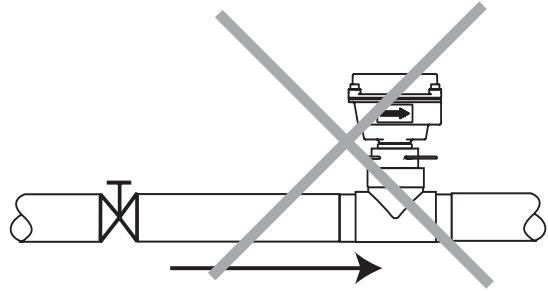

Post-valve cavitation can create air pocket

RECOMMENDED

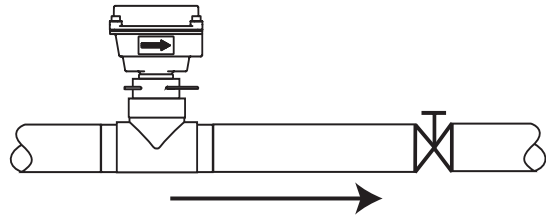

Keeps pipe full at sensor

NOT RECOMMENDED

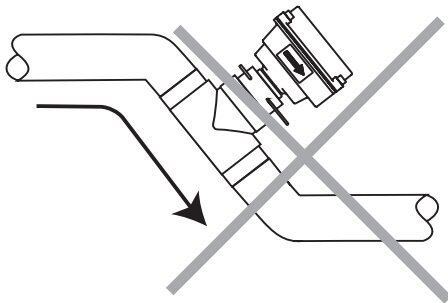

Air can be trapped

RECOMMENDED

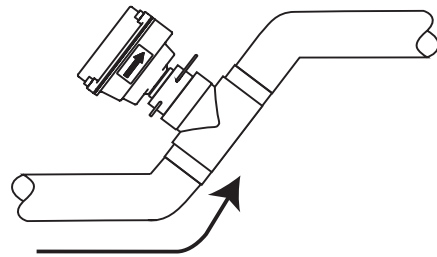

Allows air to bleed off



Caution: These flow sensors are not recommended for installation downstream of the boiler feedwater pump where installation fault may expose the flow sensor to boiler pressure and temperature. Maximum recommended temperature is 130°F (Plastic), 200°F (Metal).

ELECTRICAL CONNECTIONS

General Electrical Guidelines:

- Whenever possible avoid running control cables in the same conduit with AC power.
- Using shielded cable, be sure that one end is grounded.
- Avoid routing flow sensor cables in close proximity to a variable frequency drive.
- Recommended power and output wiring is shielded 18-22 AWG control cable.
- Recommended voltage is 12-24 VDC. Note that unregulated power supplies can vary from nameplate voltage by a considerable amount. When in doubt, use a regulated power supply.

See the Connections diagrams on the following pages for the appropriate terminals.

Power: A 12 - 24 Vdc power supply capable of at least 250 mA current output is needed.

Forward Flow Output: This open-collector isolated output does not supply power. This pulse is generated in the forward flow direction on the standard unit. (Reverse flow output is available as an option).

Note: This output is limited to 6 mA at 30 Vdc maximum.

Reverse Flow Output: Reverse flow output is available as an option. This open-collector isolated output does not supply power. It functions like a polarity-sensitive switch closure.

Note: This output is limited to 6 mA at 30 Vdc maximum.

Grounding Guidelines:

For best results, use a good quality earth ground, such as metallic water piping, or a stake driven into the ground.

If the flow sensor is installed in metallic piping, for optimum grounding clamp wires to the piping a short distance to either side of the flow sensor using hose type clamps. Connect these wires to the earth ground and to one of the housing screws. (For non-metallic piping, this step is not needed.)

EX meters are usually unaffected by moderate levels of electrical noise. In some applications performance may be improved by taking the following steps:

- Use shielded twisted pair cable (Belden 8723 or equivalent above ground or Alpha 35482 or equivalent burial).
- Clamp a ferrite bead (Steward 28A2029-OA0 or equivalent) on meter signal/power wire within 3/4" of the meter strain relief (tape or tie wrap in place if necessary). See diagram below.
- **IMPORTANT** - Connect the cable shield ground wire to ground, **ONLY** at power supply end of cable.

GROUNDING DIAGRAM

(Not needed for non-metallic pipe)

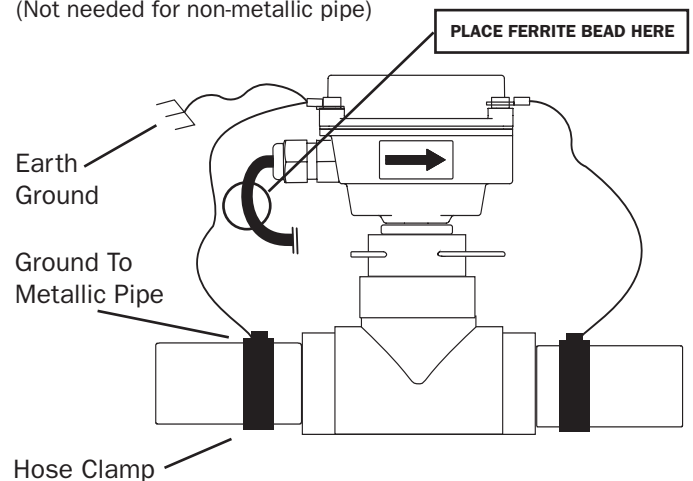

CONNECTIONS DIAGRAMS

COUNTER OR PLC

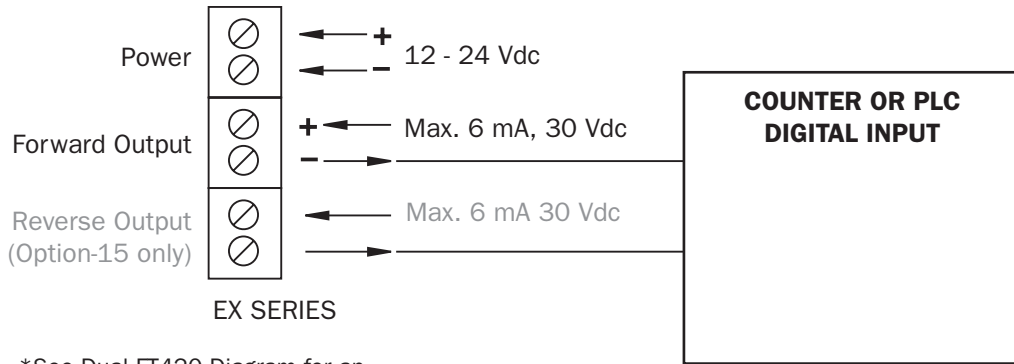

*See Dual FT420 Diagram for an example of bidirectional connections.

A055 4-20 mA OUTPUT

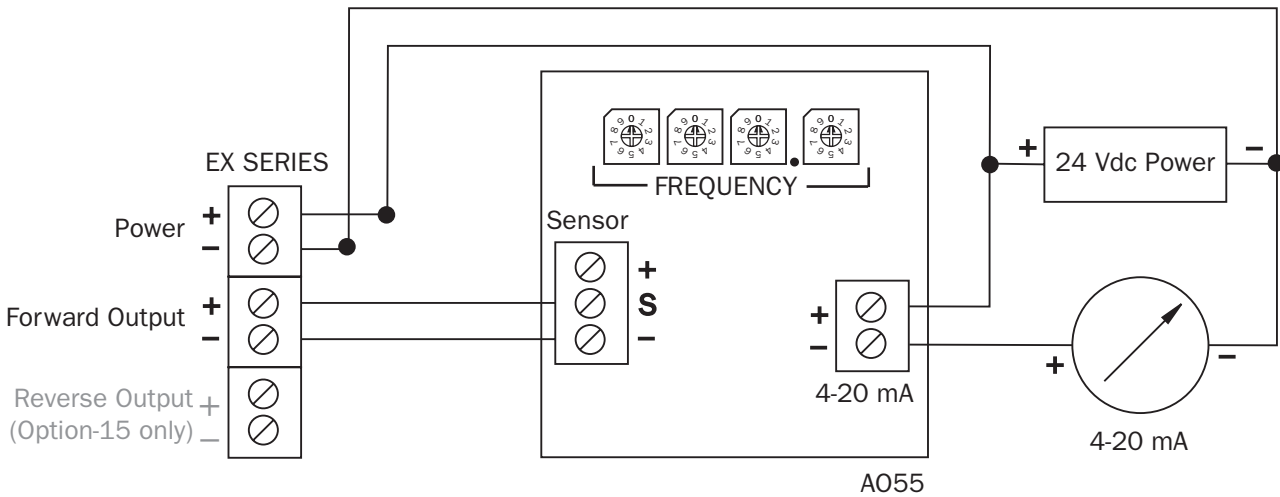

*See Dual FT420 Diagram for an example of bidirectional connections.

FT520 CONTROLLER

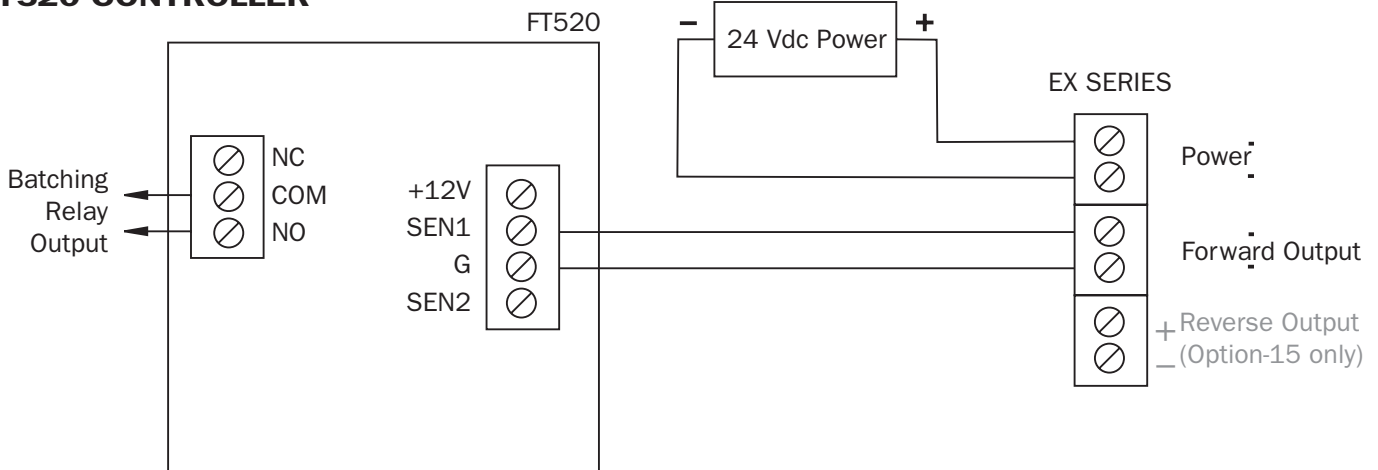

*See Dual FT420 Diagram for an example of bidirectional connections.

CONNECTIONS DIAGRAMS

FT420 DISPLAY AND PROPORTIONAL FEED

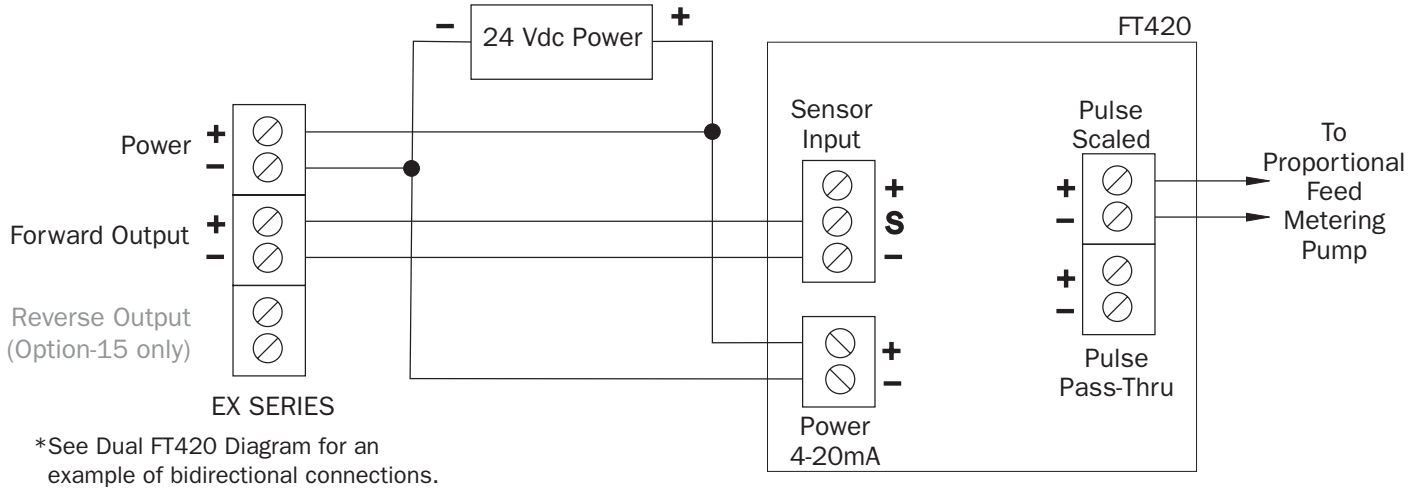

FT420 DISPLAY AND 4-20 mA OUTPUT

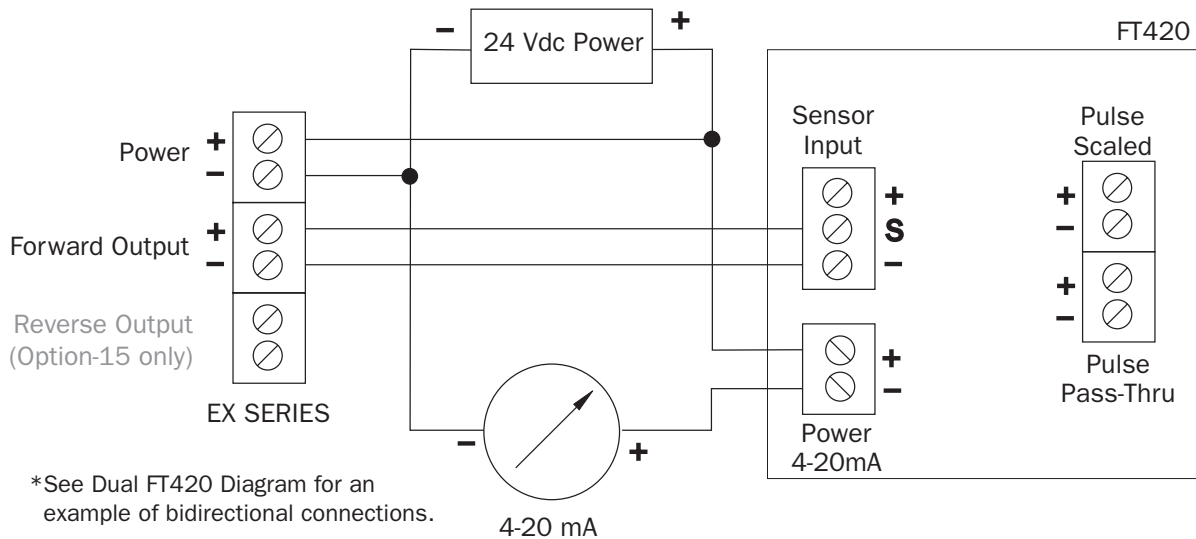

FS30 FLOW SWITCH

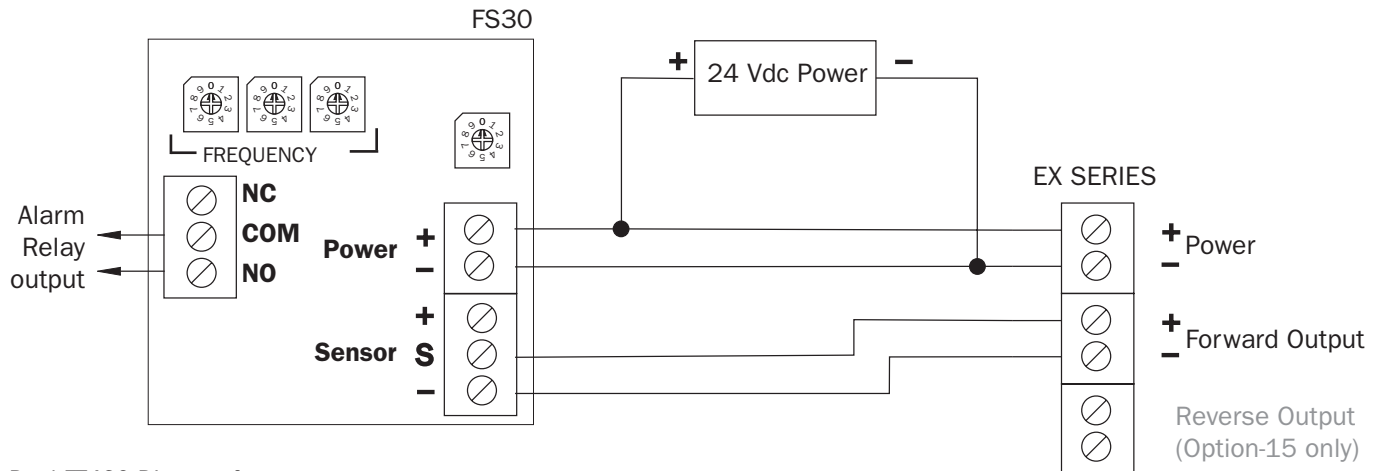

CONNECTIONS DIAGRAMS

DL75 DATA LOGGER

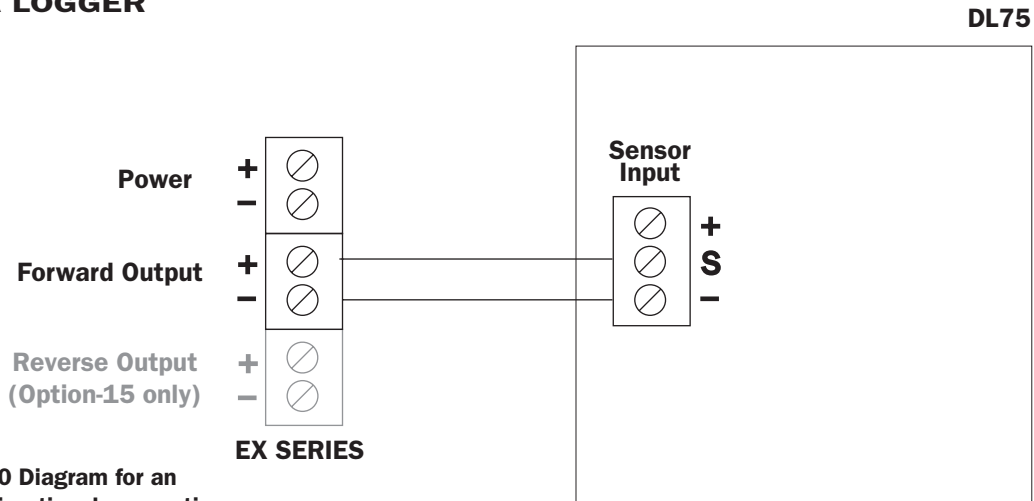

*See Dual FT420 Diagram for an example of bidirectional connections.

FT420/DL75

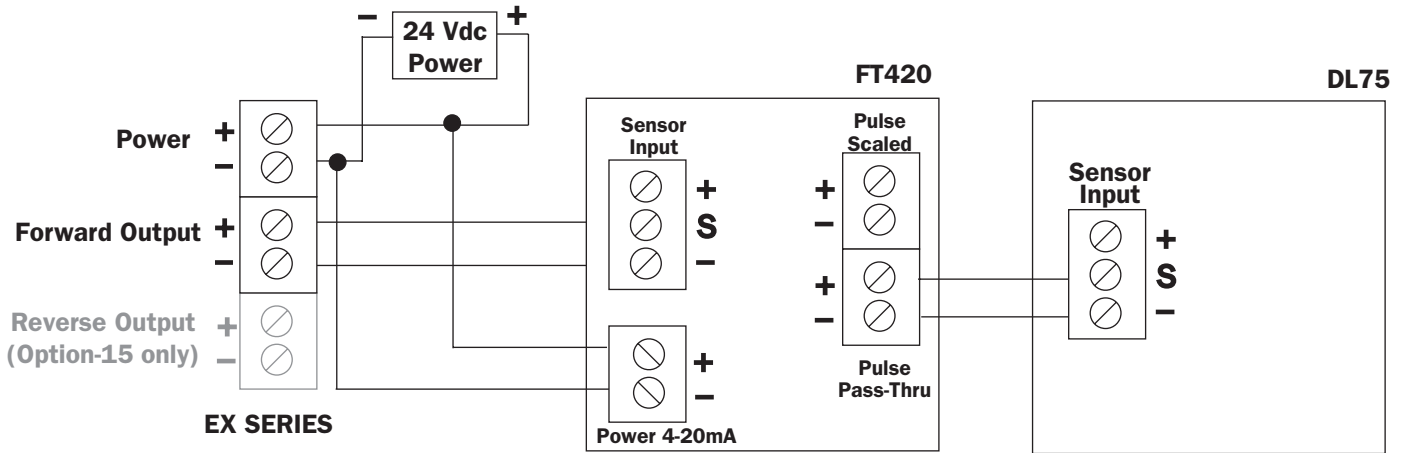

*See Dual FT420 Diagram for an example of bidirectional connections.

DUAL FT420 DISPLAYS
(Example of Bidirectional Connection)

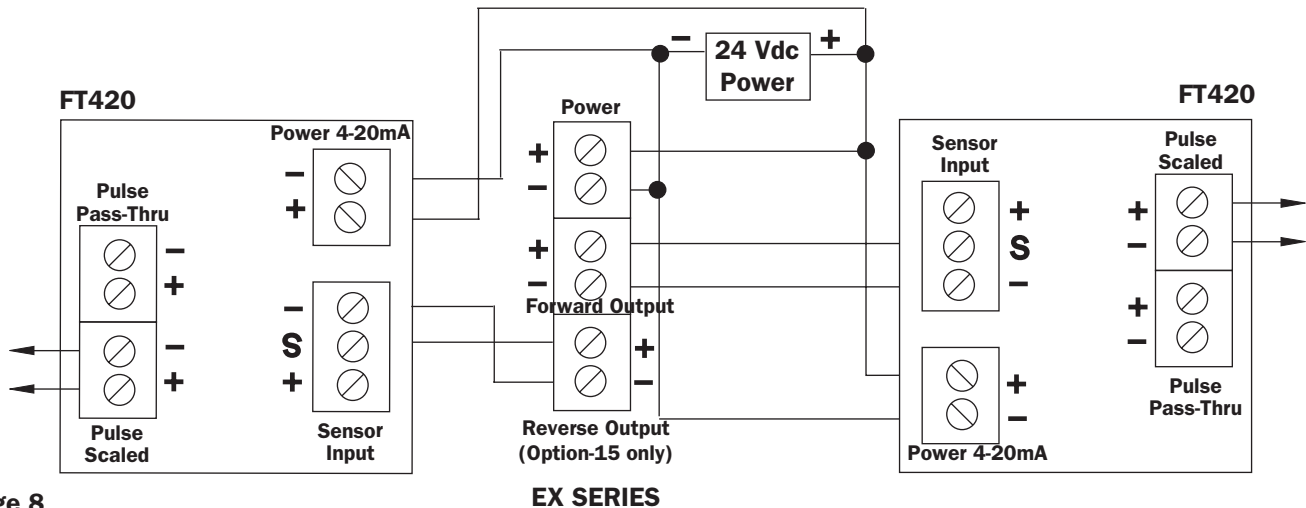

OPERATION & MAINTENANCE

Zero Adjustment. When the EX81 or 82 is powered up and there is no flow, there should be no output pulses (or, if connected to the FT420, flow rate should read “0”). If there are pulses it may be necessary to adjust the flow meter under no-flow conditions after it has been installed. This should only be done if the indicated flow is low, near the lower cutoff.

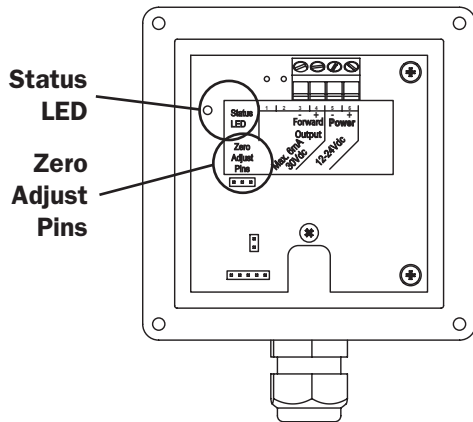

To perform the adjustment, after determining that there is a full pipe with no flow, short between the two pins marked “Zero Adjust”. A red LED light will come on for approximately 50 seconds and then go out. The zero adjustment is completed.

Minimum Flow. As with any other flow sensor, there is a rate below which the EX80-series sensor cannot read. Check the flow rate table below for the minimum flow rate detectable by the sensor for a given pipe size.

FLOW RATE (GPM)

	1"	1-1/2"	2"	3"	4"	6"	8"	10"
• Min	.50	1.1	2	4.5	8	18	31	49
• Max	50	110	196	440	783	1763	3133	4895

Presence of Flow Indication. To assist in troubleshooting, the “Status LED” has two blinking modes in normal operation. When there is no flow detectable by the meter (below minimum threshold) the LED blinks every 8.0 seconds. When there is detectable flow, the same indicator blinks every 3.0 seconds.

Filtering. The software of the EX80-series sensor filters out electrical noise and averages sudden variations in the flow to smooth the output. It takes a matter of seconds for the flow sensor to get up to full output when it is powered up or when flow begins.

Electrode Coating. Grease or other adhering, non-conductive materials can stop flow detection if the electrodes become heavily coated. To clean the electrodes, remove the sensor from the pipe and gently scrub the electrodes (three silver bumps) on the reading face of the flow sensor. A mild soap (dishwashing liquid for example) can be used to aid the cleaning process.

Calibration (“K-factor”). The K-factor represents the actual number of pulses per gallon the meter produces during a flow test. This number can be entered into your electronic control to make it read properly. If the EX80 Series meter is ordered with a **tee fitting**, it is factory-calibrated in the fitting and the K-factor is indicated on the side of the fitting (see diagram).

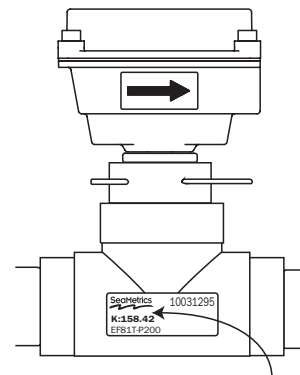

Find Your K-Factor Here

If the EX80 Series meter is ordered with a **saddle or weldolet fitting**, find your K-factor in the chart below.

K-FACTORS SADDLES & WELDOLETS					
	3"	4"	6"	8"	10"
PVC/Steel Sch. 40	70.397	40.985	18.130	10.497	6.674
PVC/Steel Sch. 80	78.748	45.360	20.084	11.495	7.322
Stainless Steel (10S)	62.385	36.626	16.510	9.642	6.173
Stainless Steel (40S)	70.397	40.985	18.130	10.497	6.674
Copper Tubing (Type L)	76.371	43.552	19.513	11.201	7.230
Copper Tubing (Type K)	78.371	44.638	20.223	11.622	7.500
Brass Pipe	70.672	41.517	17.778	10.445	6.674
Duct. Iron (Class 52)	57.376	37.320	16.915	9.503	6.197

TROUBLESHOOTING

Problem	Probable Cause	Try...
No pulse output	Pipe not full	Check Plumbing
	Below minimum flow cutoff	Check the Presence of Flow LED (see pg. 9)
	Unit not grounded	Connect to earth ground
	Excessive electrical noise	Check for proper electrical wiring
	No power	Check for power across power input terminals
	Flow Reversed	Note flow direction arrow, reverse direction of meter
	Power Reversed	Reverse connections
	Output connections reversed	Change output connections
Output pulses incorrect	Fluid conductivity <20 microseimans/cm	Select another flow meter
	Missing or incorrect ground wire	Check for proper ground
	Excessive electrical noise	Check for proper electrical wiring
	Empty pipe	Check for full pipe or install meter in the vertical position
	Not enough straight pipe	Check for ten diameters upstream AND five diameters downstream

