

Pressure Reducing Valve

Type DMV 755
Type DMV 765



Design

- ASV sturdy and robust construction

Size

- DN 10 up to DN 50

Max. Pressure

- 10 bar (PN 10) at 20 °C

Setting Range

- DMV 755: 1,0 - 9,0 bar
- DMV 765: 0,5 - 9,0 bar

Pressure Setting

- At any time also during operation

Working Pressure

- Corresponding to related material and temperature:
DMV 755: up to 9,0 bar
DMV 765: up to 9,0 bar
- Low pressure increase up to full seat opening
- High reproducibility

Back lash

- Low hysteresis of only approx. 0,1 - 0,4 bar

Operating Security

- Hermetically sealed by diaphragm with crimped O-ring
- Solid, vibration and fluttering free pressure control

Maintenance

- Maintenance free

Simple inline pipe connection

- Because of injection moulded union thread completed with union nut and inlay according to DIN 8063. Also ANSI, JIS, BSP inlays available
- Also with solvent or welding spigot ends

Because of constructive design the valves DMV 755/765 have the following features:

- High reproducibility.
- Short compact dimensions.
- With spigot ends or injection moulded threaded necks acc. to DIN 8063 and union socket ends.
- Direct mounting on any valve support by metal inserts below the body.

Range of applications:

Directly controlled by the operating fluid the DMV 755/765 reduces the primary pressure and keeps the operating pressure constant.

Valve functions and design:

The ASV valve DMV 755/765 is in working condition always open which means it is balanced between primary and secondary pressure. At any rise of working pressure - valve outlet - a pressure compensation takes place at the area below the diaphragm (control bore). The higher working pressure activates the large diaphragm and lifts the piston against the spring force. The flow reduces and the working pressure drops down until balanced condition is reached again. When the working pressure drops the described procedure reverses. The spring force opens the valve seat against the lower pressure force below the diaphragm. The flow rises until the balanced condition is reached again.

Attention:

If the secondary pressure is additionally increased by the back pressure, the pressure reducing valve works as a non-return valve. This pressure can lead to the destruction of the valve piston.

Valve setting and adjustment:

The presetting or readjustment is made by removing the protection cap at setting control screw with a counternut and by reading the set pressure from the ASV diaphragm pressure gauge guard type 901 in the pipe system. The counternut can be leaded.

Sectional View DMV 755

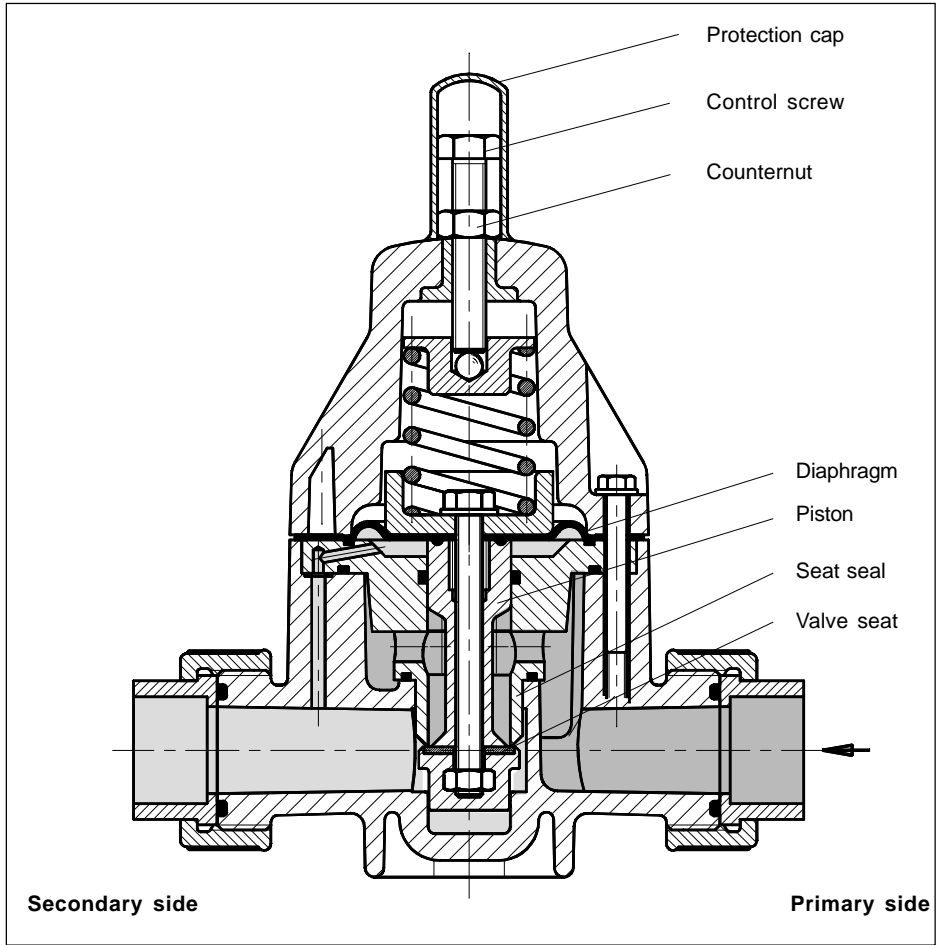

Pressure reducing valve with pressure gauge:

For neutral fluids the valve can be equipped with a gauge either at the primary or also at the secondary side.

Flow Diagram:

See at page 11.

Pressure reducing valve with pressure gauge

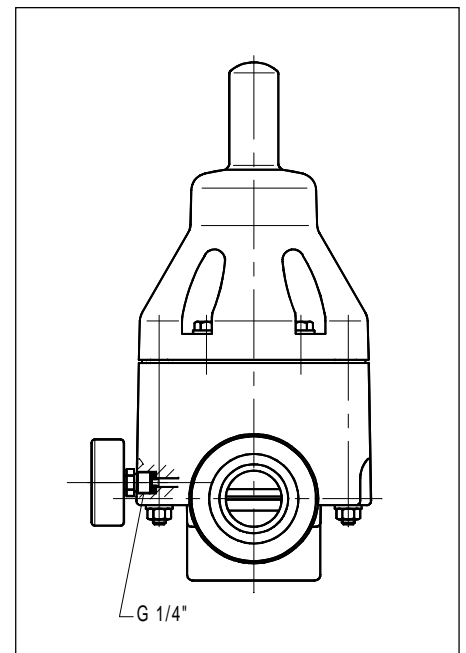

Material

Only thermoplastic material with high impact strength and high creep strength is used by ASV Stübbe.

Valve body, piston, separation disc:

- uPVC (Polyvinyl Chloride)
- PP (Polypropylene)
- PVDF (Polyvinylidene Fluoride)

Valve bonnet:

- PP glass-fiber reinforced

Moulded diaphragm:

- EPDM, PTFE coated on fluid side

Valve seat seal:

- EPDM
- FPM

O-ring sealings at union ends:

- EPDM
- FPM

Screws, nuts and washers:

- SS (AISI 304)

Technical Data

Type of fluids:

Neutral, aggressive or gaseous liquids provided that the selected materials are resistant at operating temperature. Refer to the ASV resistance guide.

Installation:

Arrow of flow direction must always be considered.

Nominal pressure:

PN 10 at +20 °C.

Operating pressure:

See material dependent pressure/temperature-diagram.

Working pressure:

- DMV 755: 1,0 - 9,0 bar
- DMV 765: 0,5 - 9,0 bar

Hysteresis:

Difference between opening and closing pressure: approx. 0,1 - 0,4 bar

Fluid temperature:

Depends on the operating conditions (system pressure, load etc.). Taking creep strength into account, the following approximate temperatures apply:

- uPVC: + 50 °C
- PP: + 70 °C
- PVDF: +100 °C

Colour of body:

- uPVC grey, RAL 7011
- PP grey, RAL 7032
- PVDF opaque (yellowish white)

Colour of bonnet:

- PP orange, RAL 2005

Pressure/temperature-diagram:

The pressure/temperature limits are applicable for a computed operating life factor of 25 years.

The values are a guide for harmless fluids (DIN 2403) against which the material of the valve is resistant.

The curves are valid for a calculated lifetime of about 25.

Values < 0 °C (PP < +10 °C) on request with exact data of operation.

Connection:

1. Body with union thread acc. DIN 8063 completed with:

- union nuts made of uPVC, PP or PVDF
- inserts with socket ends out of uPVC, PP or PVDF
- O-ring sealings in EPDM or FPM

On request we deliver:

- inserts with spigot ends for fusion welding made of PP or PE
- dimensions acc. BS, ANSI and JIS on request

2. Body with spigot ends for solvent or fusion welding acc. ISO/DIN

We kindly ask for your inquiry.

Pressure/temperature diagram

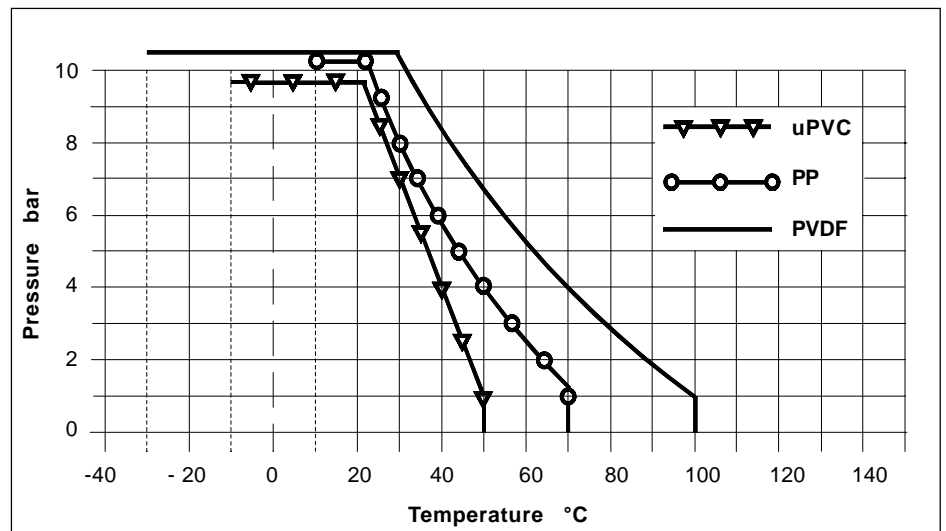

Dimensions DMV 755, DMV 765 with union socket ends

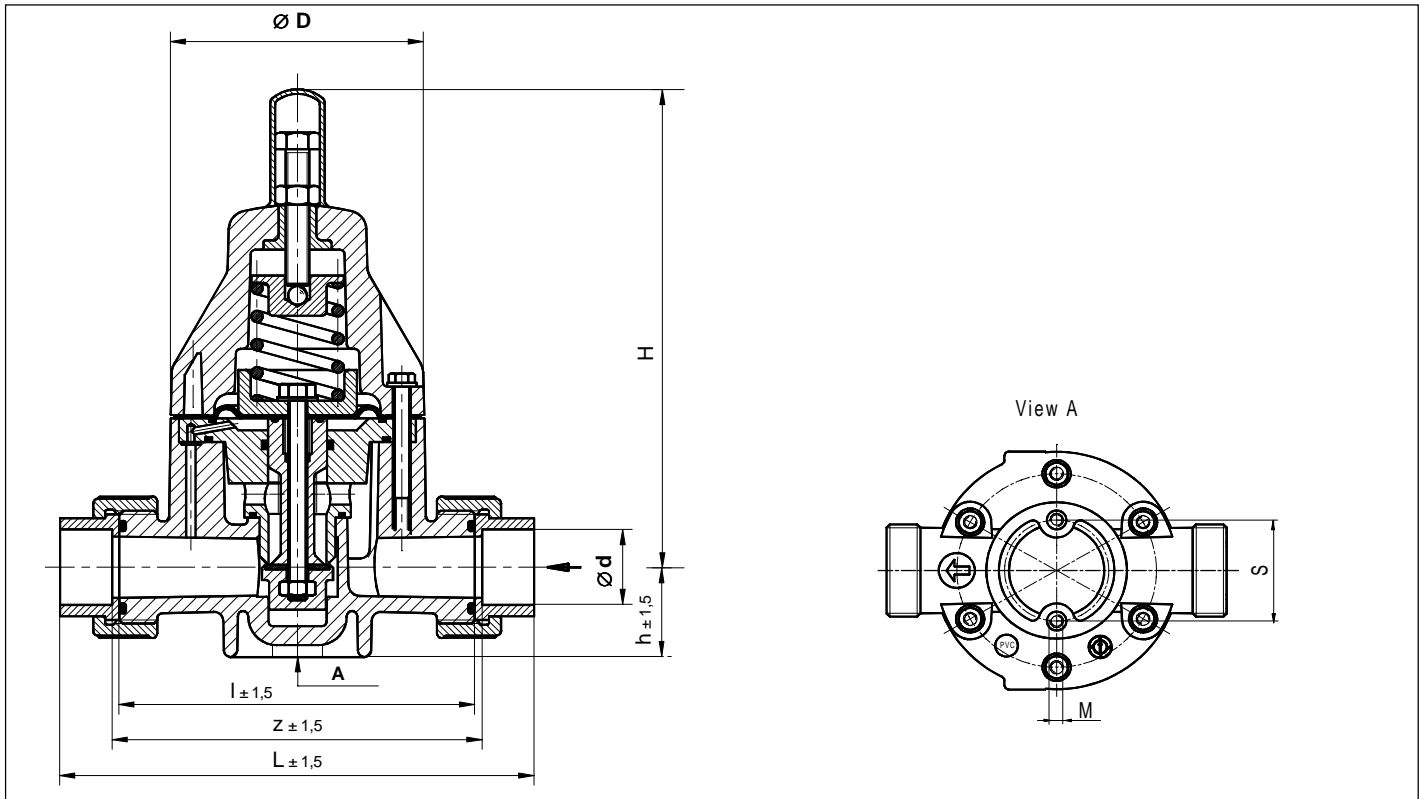

For DMV 755 with union socket ends

Size			Dimensions mm												Weight (kg) (standard value)			
d mm	DN mm	DN Inch	L			l		z		h		H	D	M	s	PVC	PP	PVDF
			PVC	PP	PVDF	PVC*	PVDF	PVC*	PVDF	PVC*	PVDF							
16	10	3/8	154	155	154	120	118	126	124	25	24	174	81	M 6	40	0,80	0,67	1,02
20	15	1/2	159	154	156	120	118	126	124	25	24	174	81	M 6	40	0,85	0,72	1,07
25	20	3/4	195	188	189	150	147	156	153	37	36	202	107	M 6	46	1,86	1,57	2,11
32	25	1	201	192	193	150	147	156	153	37	36	202	107	M 6	46	1,90	1,61	2,15
40	32	1 1/4	263	251	250	205	200	211	207	57	54	262	147	M 8	65	5,00	4,10	5,45
50	40	1 1/2	273	257	256	205	200	211	207	57	54	262	147	M 8	65	5,10	4,18	5,55
63	50	2	287	265	264	205	200	211	207	57	54	262	147	M 8	65	5,20	4,28	5,65

For DMV 765 with union socket ends

Size			Dimensions mm												Weight (kg) (standard value)			
d mm	DN mm	DN Inch	L			l		z		h		H	D	M	s	PVC	PP	PVDF
			PVC	PP	PVDF	PVC*	PVDF	PVC*	PVDF	PVC*	PVDF							
16	10	3/8	154	155	154	120	118	126	124	25	24	207	81	M 6	40	0,98	0,82	1,20
20	15	1/2	159	154	156	120	118	126	124	25	24	207	81	M 6	40	1,00	0,84	1,24
25	20	3/4	195	188	189	150	147	156	153	37	36	243	107	M 6	46	2,20	1,90	2,45
32	25	1	201	192	193	150	147	156	153	37	36	243	107	M 6	46	2,25	1,95	2,52
40	32	1 1/4	263	251	250	205	200	211	207	57	54	348	147	M 8	65	6,00	5,20	6,45
50	40	1 1/2	273	257	256	205	200	211	207	57	54	348	147	M 8	65	6,21	5,41	6,66
63	50	2	287	265	264	205	200	211	207	57	54	348	147	M 8	65	6,40	5,60	6,87

*valid also for PP

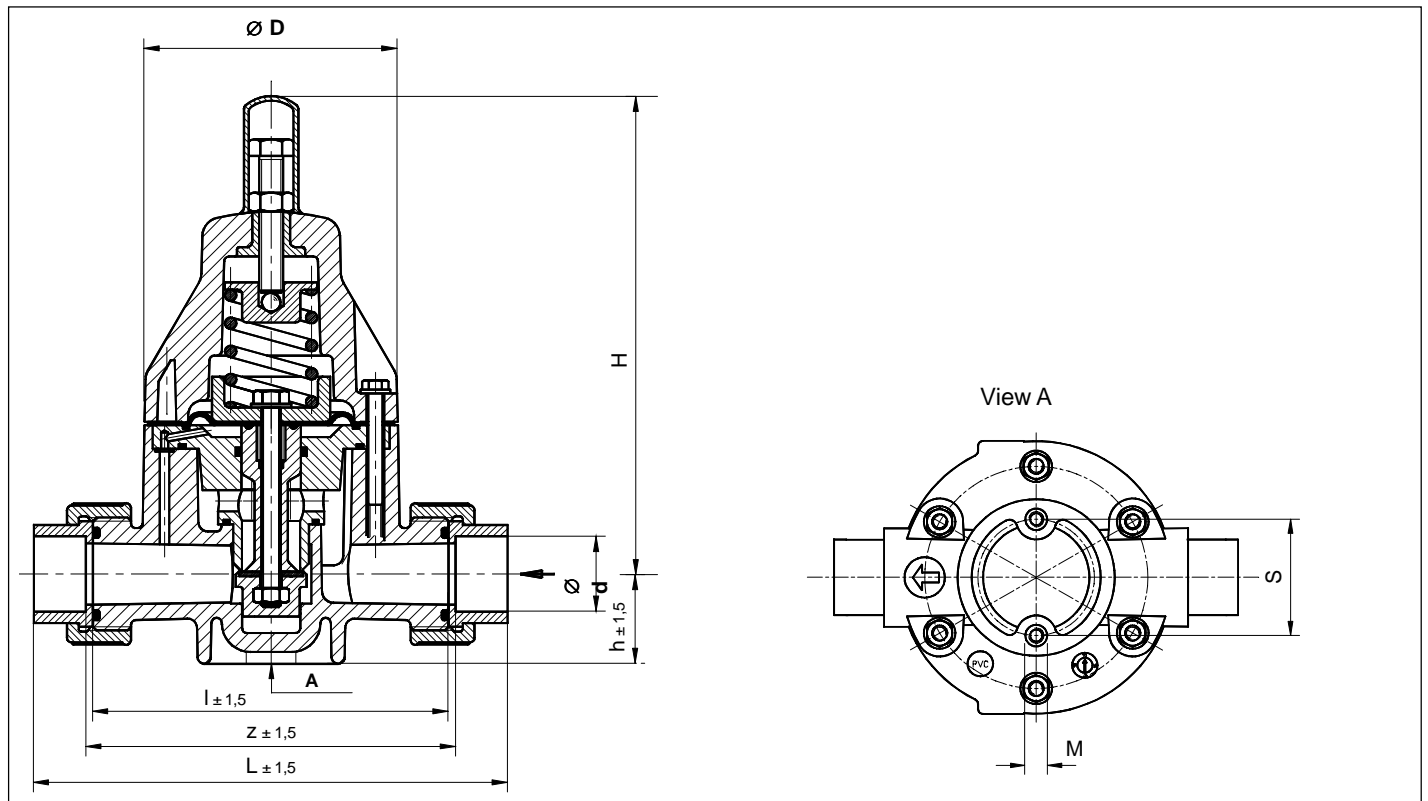
Dimensions DMV 755, DMV 765 with spigot ends

For DMV 755 with spigot ends

Size			Dimensions mm										Weight kg (appr.)		
d mm	DN mm	DN Inch	uPVC	L	PVDF	l	h		H	D	M	s	uPVC	PP	PVDF
			uPVC*	PP	PVDF		uPVC*	PVDF							
16	10	3/8	144 \pm 1	144 \pm 2,1	144 \pm 2,1	14	25	24	174	81	M 6	40	0,80	0,67	1,02
20	15	1/2	144 \pm 1	144 \pm 2,1	144 \pm 2,1	16	25	24	174	81	M 6	40	0,85	0,72	1,07
25	20	3/4	174 \pm 1	174 \pm 2,6	174 \pm 2,6	19	37	36	202	107	M 6	46	1,86	1,57	2,11
32	25	1	174 \pm 1	174 \pm 2,6	174 \pm 2,6	22	37	36	202	107	M 6	46	1,90	1,61	2,15
40	32	1 1/4	224 \pm 1,1	224 \pm 3,3	224 \pm 3,3	26	57	54	262	147	M 8	65	5,00	4,10	5,45
50	40	1 1/2	224 \pm 1,1	224 \pm 3,3	224 \pm 3,3	31	57	54	262	147	M 8	65	5,10	4,18	5,55
63	50	2	244 \pm 1,2	244 \pm 3,6	244 \pm 3,6	38	57	54	262	147	M 8	65	5,20	4,28	5,65

For DMV 765 with spigot ends

Size			Dimensions mm										Weight kg (appr.)		
d mm	DN mm	DN Inch	uPVC	L	PVDF	l	h		H	D	M	s	uPVC	PP	PVDF
			uPVC*	PP	PVDF		uPVC*	PVDF							
16	10	3/8	144 \pm 1	144 \pm 2,1	144 \pm 2,1	14	25	24	207	81	M 6	40	0,80	0,67	1,02
20	15	1/2	144 \pm 1	144 \pm 2,1	144 \pm 2,1	16	25	24	207	81	M 6	40	0,85	0,72	1,07
25	20	3/4	174 \pm 1	174 \pm 2,6	174 \pm 2,6	19	37	36	243	107	M 6	46	1,86	1,57	2,11
32	25	1	174 \pm 1	174 \pm 2,6	174 \pm 2,6	22	37	36	243	107	M 6	46	1,90	1,61	2,15
40	32	1 1/4	224 \pm 1,1	224 \pm 3,3	224 \pm 3,3	26	57	54	348	147	M 8	65	5,00	4,10	5,45
50	40	1 1/2	224 \pm 1,1	224 \pm 3,3	224 \pm 3,3	31	57	54	348	147	M 8	65	5,10	4,18	5,55
63	50	2	244 \pm 1,2	244 \pm 3,6	244 \pm 3,6	38	57	54	348	147	M 8	65	5,20	4,28	5,65

*valid also for PP

ID-No. for type DMV 755 with union socket ends

Housing Diaphragm/Seal Set Range (bar)			uPVC PTFE/EPDM 1,0 - 9,0	uPVC PTFE/FPM 1,0 - 9,0	PP PTFE/EPDM 1,0 - 9,0	PP PTFE/FPM 1,0 - 9,0	PVDF PTFE/EPDM 1,0 - 9,0	PVDF PTFE/FPM 1,0 - 9,0
d mm	DN mm	DN Inch	ID-No.	ID-No.	ID-No.	ID-No.	ID-No.	ID-No.
16	10	3/8	119300	119307	119314	119321	119328	119335
20	15	1/2	119301	119308	119315	119322	119329	119336
25	20	3/4	119302	119309	119316	119323	119330	119337
32	25	1	119303	119310	119317	119324	119331	119338
40	32	1 1/4	119304	119311	119318	119325	119332	119339
50	40	1 1/2	119305	119312	119319	119326	119333	119340
63	50	2	119306	119313	119320	119327	119334	119341

ID-No. for type DMV 755 with spigot ends

Housing Diaphragm/Seal Set Range (bar)			uPVC PTFE/EPDM 1,0 - 9,0	uPVC PTFE/FPM 1,0 - 9,0	PP PTFE/EPDM 1,0 - 9,0	PP PTFE/FPM 1,0 - 9,0	PVDF PTFE/EPDM 1,0 - 9,0	PVDF PTFE/FPM 1,0 - 9,0
d mm	DN mm	DN Inch	ID-No.	ID-No.	ID-No.	ID-No.	ID-No.	ID-No.
16	10	3/8	122048	122055	122062	122069	122076	122083
20	15	1/2	122049	122056	122063	122070	122077	122084
25	20	3/4	122050	122057	122064	122071	122078	122085
32	25	1	122051	122058	122065	122072	122079	122086
40	32	1 1/4	122052	122059	122066	122073	122080	122087
50	40	1 1/2	122053	122060	122067	122074	122081	122088
63	50	2	122054	122061	122068	122075	122082	122089

ID-No. for type DMV 765 with union socket ends

Housing Diaphragm/Seal Set Range (bar)			uPVC PTFE/EPDM 0,5 - 9,0	uPVC PTFE/FPM 0,5 - 9,0	PP PTFE/EPDM 0,5 - 9,0	PP PTFE/FPM 0,5 - 9,0	PVDF PTFE/EPDM 0,5 - 9,0	PVDF PTFE/FPM 0,5 - 9,0
d mm	DN mm	DN Inch	ID-No.	ID-No.	ID-No.	ID-No.	ID-No.	ID-No.
16	10	3/8	119342	119349	119356	119363	119370	119377
20	15	1/2	119343	119350	119357	119364	119371	119378
25	20	3/4	119344	119351	119358	119365	119372	119379
32	25	1	119345	119352	119359	119366	119373	119380
40	32	1 1/4	119346	119353	119360	119367	119374	119381
50	40	1 1/2	119347	119354	119361	119368	119375	119382
63	50	2	119348	119355	119362	119369	119376	119383

ID-No. for Type DMV 765 with spigot ends

Housing Diaphragm/Seal Set Range (bar)			uPVC PTFE/EPDM 0,5 - 9,0	uPVC PTFE/FPM 0,5 - 9,0	PP PTFE/EPDM 0,5 - 9,0	PP PTFE/FPM 0,5 - 9,0	PVDF PTFE/EPDM 0,5 - 9,0	PVDF PTFE/FPM 0,5 - 9,0
d mm	DN mm	DN Inch	ID-No.	ID-No.	ID-No.	ID-No.	ID-No.	ID-No.
16	10	3/8	122090	122097	122104	122111	122118	122125
20	15	1/2	122091	122098	122105	122112	122119	122126
25	20	3/4	122092	122099	122106	122113	122120	122127
32	25	1	122093	122100	122107	122114	122121	122128
40	32	1 1/4	122094	122101	122108	122115	122122	122129
50	40	1 1/2	122095	122102	122109	122116	122123	122130
63	50	2	122096	122103	122110	122117	122124	122131

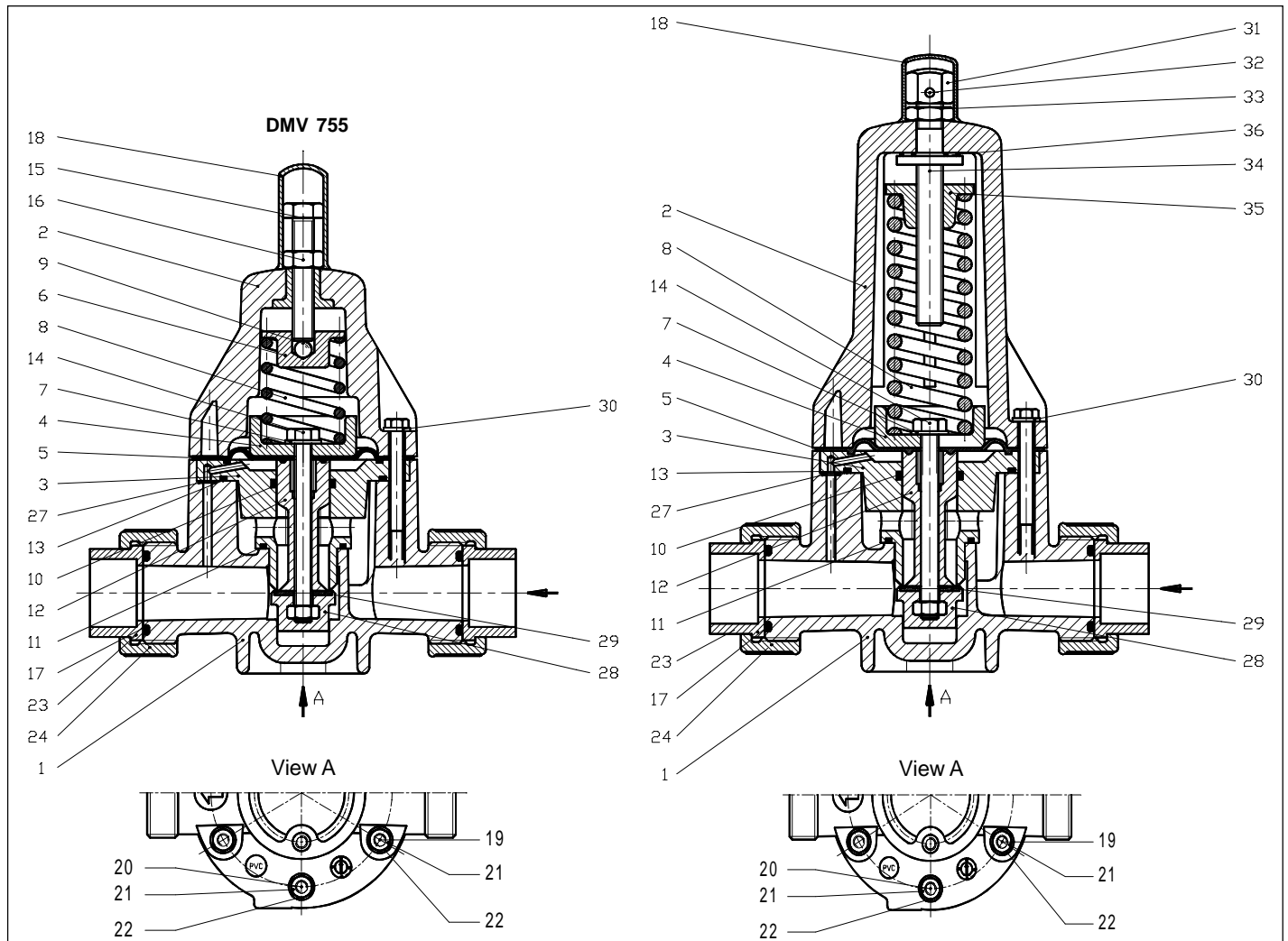
Spare Part List

Pos.	Description	Qty.	Pos.	Description	Qty.
1	Valve Body	1	19	Hex.-Screw	4
2	Bonnet	1	20	Hex.-Screw	2
3	Separation Disc *	1	21	Hex.-Nut	4/6
4	Spring Plate	1	22	Washer	4/6
5	Diaphragm *	1	23	Socket	2
6	Pressure Plate	1	24	Union Nut	2
7	Washer	1	25	Protection Cap	4/6
8	Spring	1	26	Protection Cap	4/6
9	Steel Ball	1	27	O-ring sealing *	1
10	O-ring sealing *	1	28	Pistonguide *	1
11	O-ring sealing *	1	29	Flat Seal *	1
12	Piston *	1	30	Washer	4/6
13	O-ring sealing*	1	31	Cap Nut	1
14	Hex.-Screw	1	32	Spring dowel sleeve	1
15	Hex.-Screw	1	33	Counternut	1
16	Counter Nut	1	34	Spinn	1
17	O-ring sealing*	2	35	Pressure Plate	1
18	Protection Cap	1	36	Bearing *	1

* Spare parts

Characteristic Curves DMV 755

Working pressure p_A above the flow Q l/h.
 Parameter is set pressure p_E at $Q = 0$ l/h.

The curves are valid for water at +20 °C.

The respective top and lower curve show the reseal respectively opening pressure progression.

DN 10

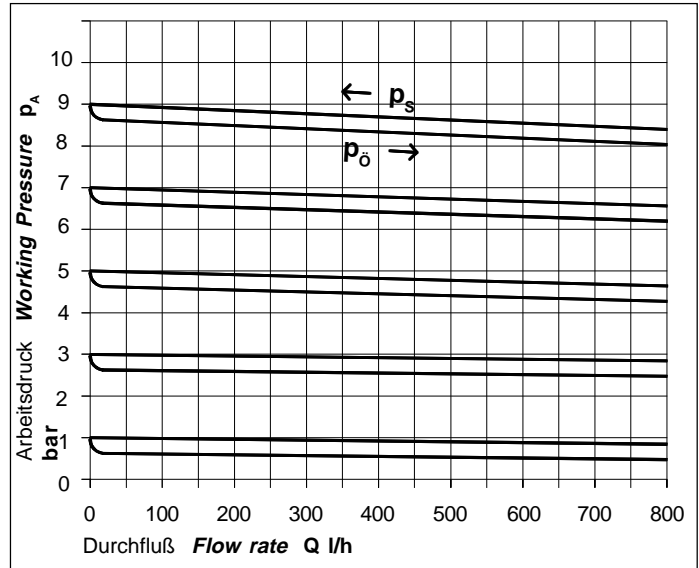

DN 15

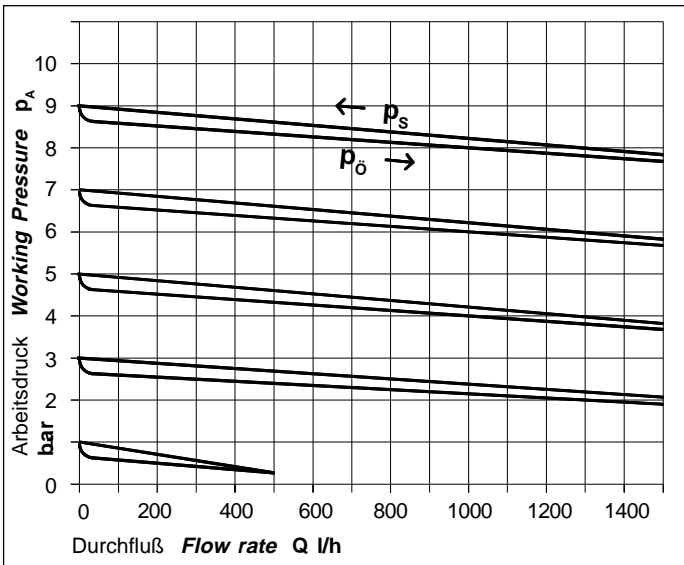

DN 20

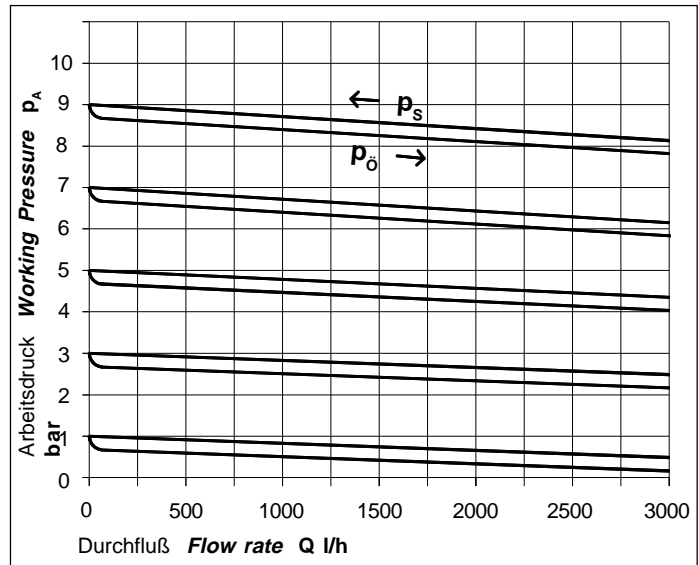

DN 25

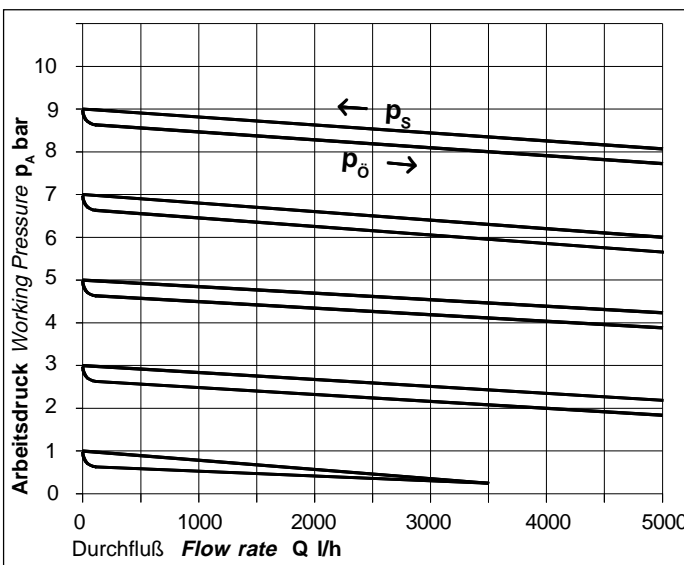

DN 32

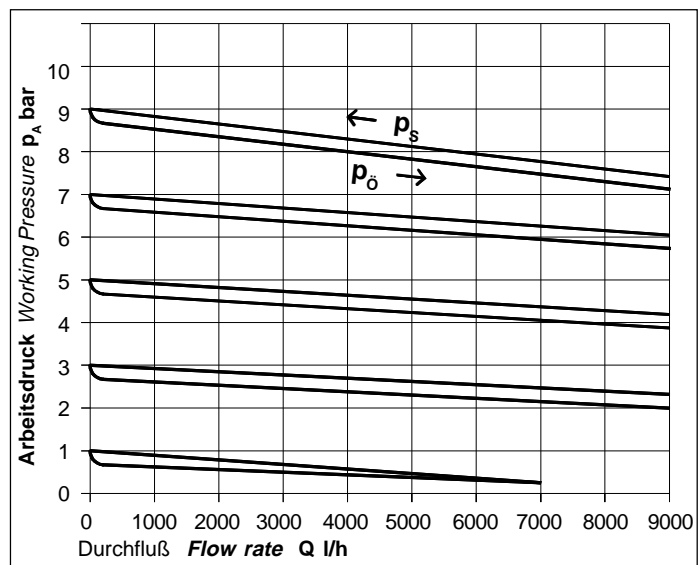

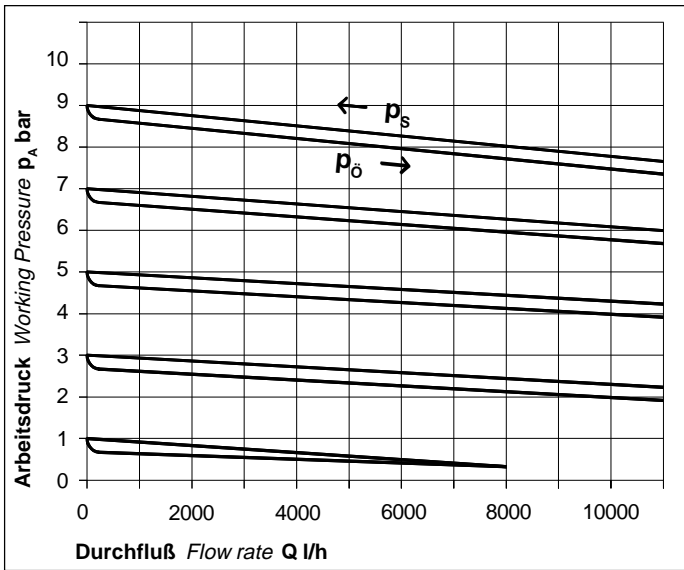
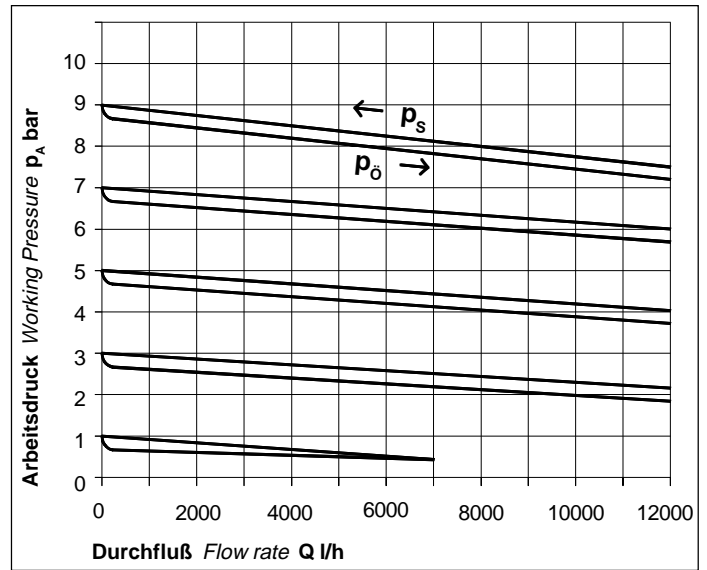
DN 40

DN 50

Characteristic Curves DMV 765

Working pressure p_A above the flow Q l/h.

Parameter is set pressure p_E at $Q = 0$ l/h.

The curves are valid for water at $+20$ °C.

The respective top and lower curve show the reset respectively opening pressure progression.

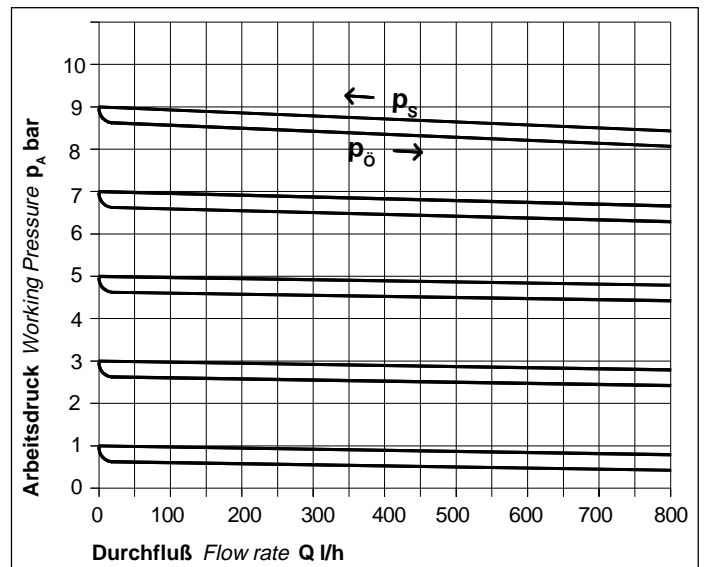
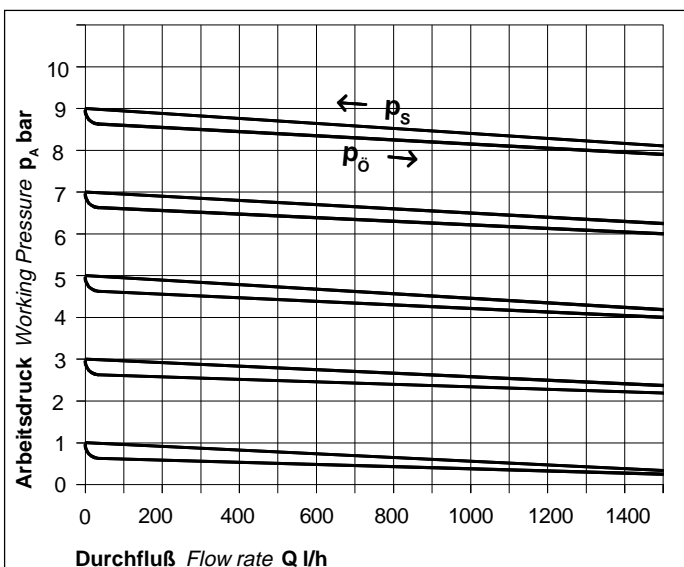
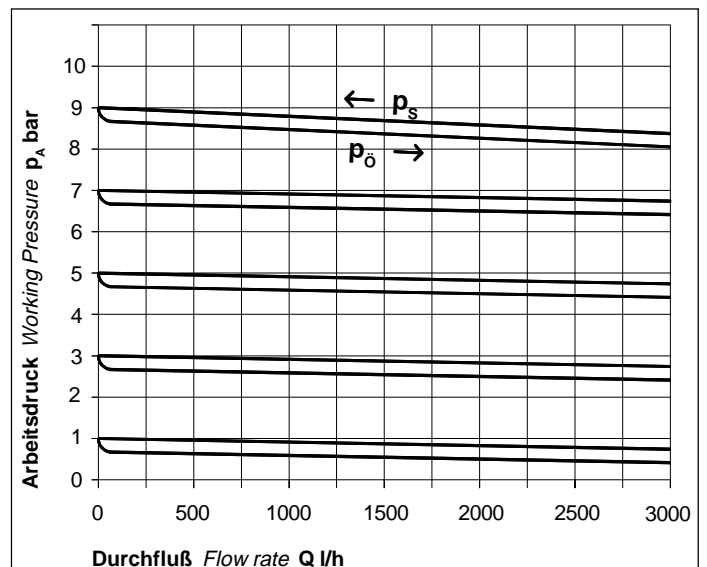
DN 10

DN 15

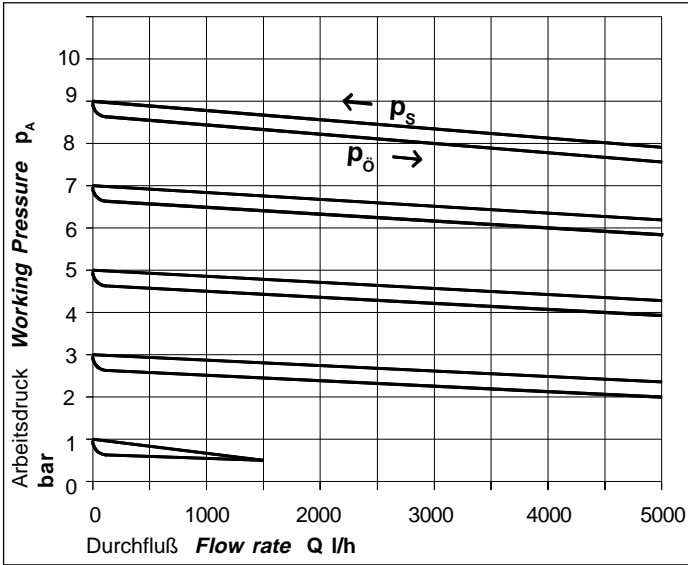
DN 20

DN 25

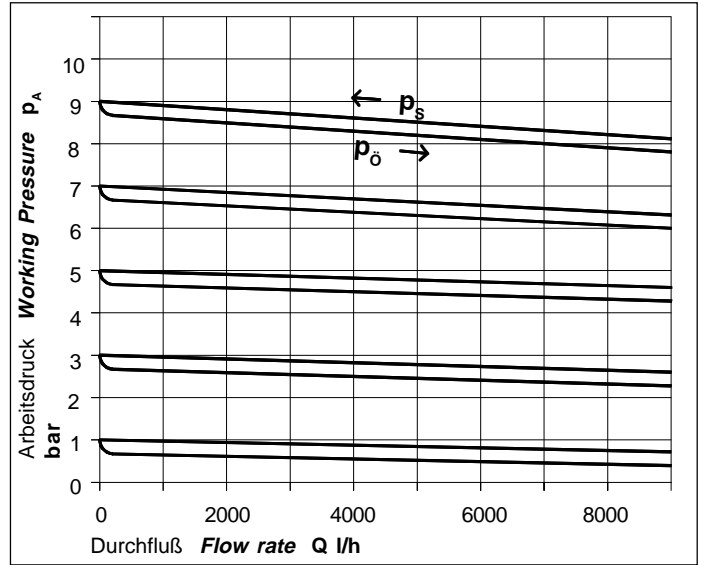

DN 32



DN 40

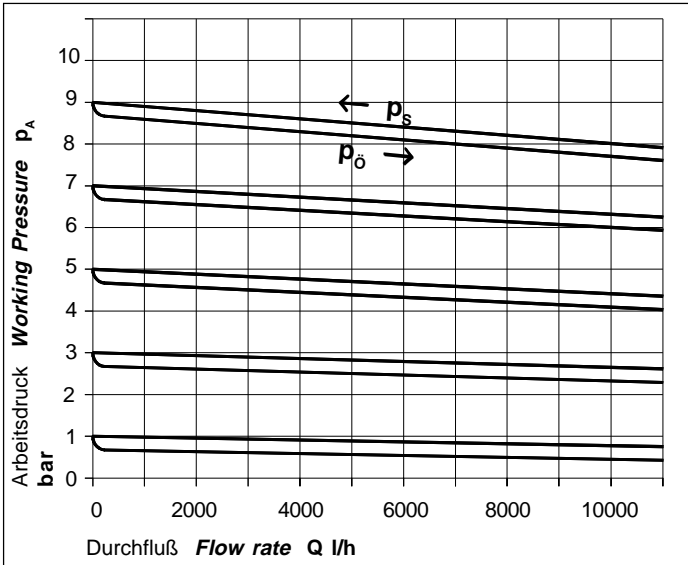

DN 50

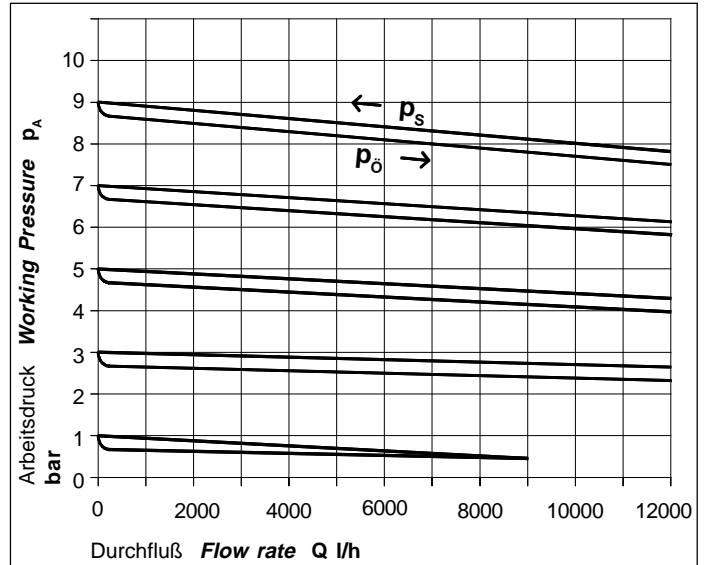

Operation conditions:

p_E = Set pressure

p_A = Working pressure

p_S = Closing pressure

$p_A = p_S$

$p_{\ddot{o}}$ = Opening pressure

$p_S - p_{\ddot{o}} = \text{Hysteresis}$

$p_E - p_A = \text{Flow depending pressure reduction}$

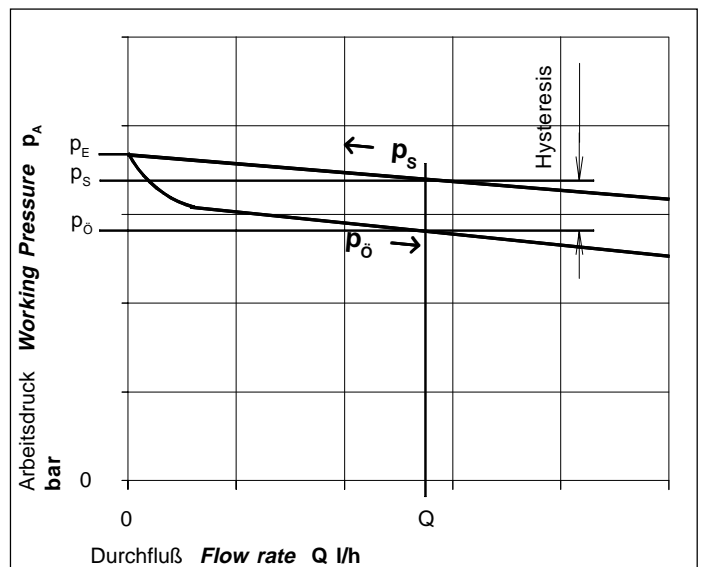

Application of Pressure Reducing Valve

Working condition 1

If shut-off valve opens the working pressure p_A drops by an opening pressure p_0

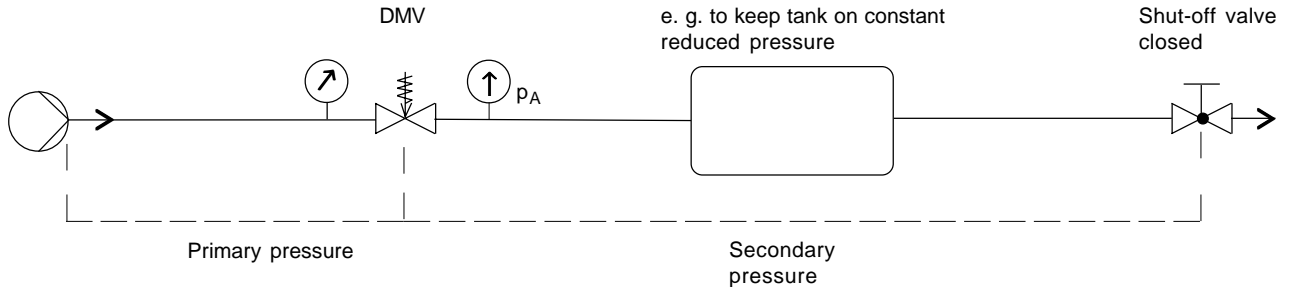

Working condition 2

If shut-off valve closes the working pressure p_A rises by the a closing pressure p_S

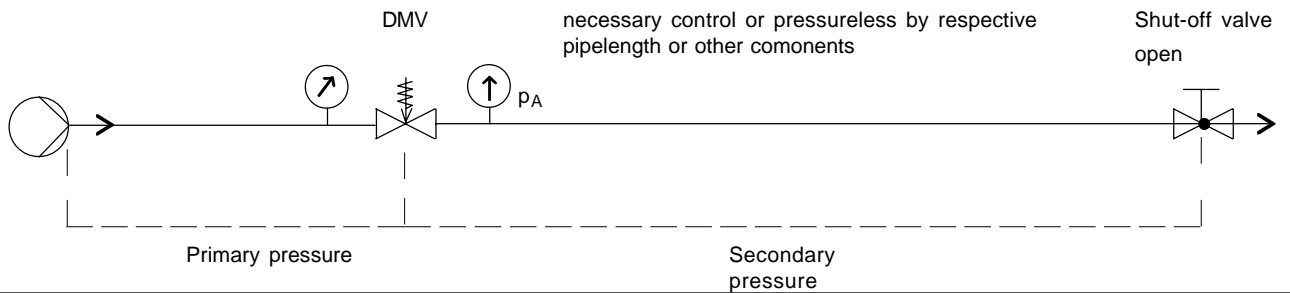

Failures, possible Causes and Repair

Failures	Possible causes	Repair
Valve at diaphragm leaking.	Diaphragm clamping pressure too low. O-ring sealing damaged.	Fasten screw (pos. 19, pos. 20). O-ring sealing (pos. 13) to be replaced.
Pressure rises above set pressure.	Seat seal leaking. Diaphragm leaking. O-ring sealing leaking. Control bore at body and/or separation disc dirty. Pistonguide is jammed or dirty.	Seat seal (pos. 29) to be replaced. Diaphragm (pos. 5) to be replaced. O-ring sealing (pos. 10, 11 and pos. 13, 27) to be replaced. Dismount valve and clean bore. Valve to be cleaned.
Valve closed (does not open).	Valve mounted in wrong direction.	Turn valve in direction of arrows.
Valve is leaking at control screw.	Diaphragm damaged.	Replace diaphragm (Pos. 5).

Operating instructions



Safe operation of the valve can only be ensured if it is properly installed, operated, serviced or repaired

by qualified personnel according to its intended use while observing the accident prevention regulations, safety regulations, standards and technical regulations.

The intended use includes adhering to the specified limit values for pressure and temperature as well as the chemical resistance referring to the operating conditions.

For this purpose, ensure that all components getting in contact with the media are »resistant« in accordance to the ASV resistance guide.

The owner/user must inform the authorized qualified personnel instructed to perform the assembly, inspection and/or maintenance work of any potential danger emanating from the machine line/medium, and ensure that suitable safety measures are observed including local regulations and laws of the territories of use.

Non-observance of the specified information and safety instructions may lead to injuries and/or property damages.

Installation:

- Depending on the type of connection the pipe ends have to be properly prepared acc. to all technical standards.
- Valve to be radially installed acc. to all technical standards between the pipe ends.

In case of flange connections the torques for the screws to fasten the flanges have to be observed.

- After proper installation the pipe system with all components has to be tested for leakages.

Disassembly:

Note Observe the operating instructions.

- I required protection clothes must be worn.
- The pipe section is to be shut-off and to be emptied.
- Any fluid rest is to be disposed properly.

1. Valve bonnet:

- 1.1 Position the valve upright.
- 1.2 Remove cap (18).
- 1.3 Loosen counter nut (16) and setting control screw (15), for DMV 765 (33 and 34), so far that the spring (8) in the bonnet is totally released.
- 1.4. Remove housing bolts and nuts (19, 20) from valve body (1) and bonnet (2).
- 1.5. Bonnet (2) to be lifted upwards. Remove spring (8), pressure plate (6) and steel ball (9), for DMV 765 only the spring (8).

2. Valve body and diaphragm

- 2.1. Disassembly of bonnet the same way as from 1.1 to 1.5.
- 2.2. Spring plate (4) with piston (12), diaphragm (5), separation disc (3), flat seal (29) and pistonguide (28) to be pulled out of the valve body (1). Remove the O-rings (13, 27 and 11) with a blunt tool.
- 2.3 Loosen srew (pos. 14) and remove pistonguide (pos. 28). Release screw (pos. 14) out of piston (pos. 12). Remove flat seal (pos. 29). Piston (pos. 12) to be lifted upwards. Remove O-ring sealing out of separation disc with a blunt tool. Secure diaphragm (pos. 5).

3. Assembly

In the reverse order to disassembly.

Note Check by assembling the correct position of the separation-disc-bore and the control-bore.

- Diaphragm, flat seals, O-ring sealings to be checked for damages and dimension deviations. Shore hardness to be checked. Replace if necessary.
- Screw torque:
M 6 and M 8: appr. 6 Nm

Note Elastomeres, especially the EPDM sealing elements, should not be touched or cleaned with synthetic oils, mineral oils, fats or cleaning agents. Danger of swelling. Only appropriate fats should be used, e.g. silicone greases.

We recommend:

Installing of filter or strainer (see print No. 310 034) directly before valve for avoiding impurities e.g. at valve seat.

Technical alterations excepted